



# SERVICE MANUAL

---

**SJ3215, SJ3219**

DC ELECTRIC SCISSORS

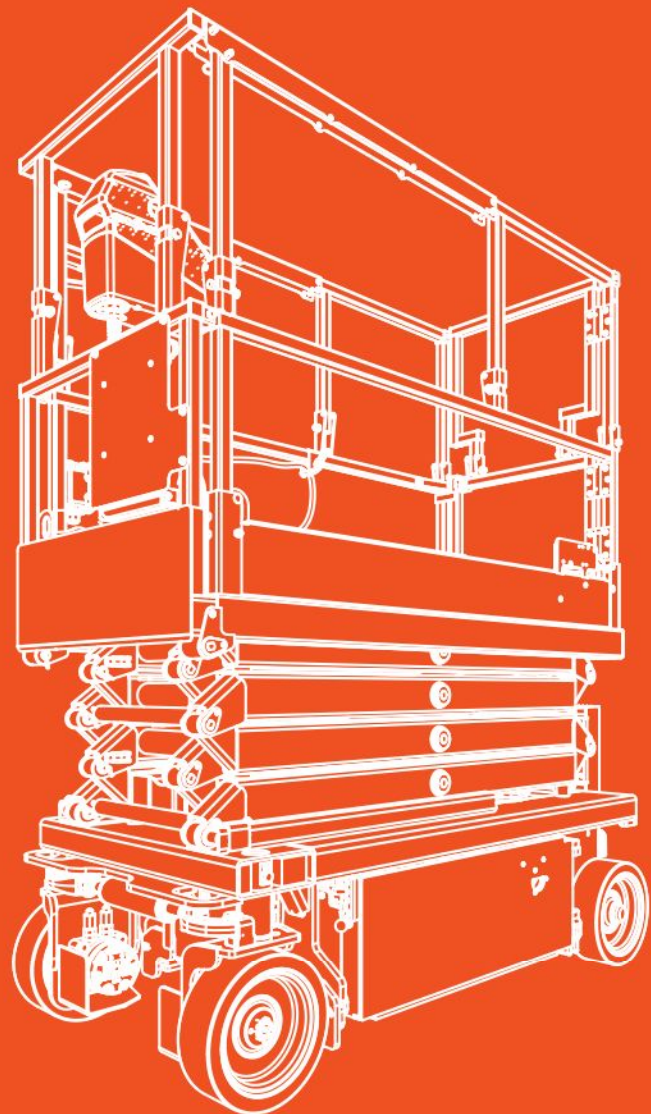

**212508ADA**

September 22, 2021  
ANSI/CSA, CE, AS, KC

**This manual is for MEWPs with serial numbers:**

**SJ3215 and SJ3219: A/B100 000 001 to A/B100 999 999**

**Please refer to the website ([www.skyjack.com](http://www.skyjack.com)) for contact information, other serial numbers, the most recent technical manuals, and USB software.**

---

**THIS SAFETY ALERT SYMBOL MEANS ATTENTION!**



**BECOME ALERT! YOUR SAFETY IS INVOLVED.**

The Safety Alert Symbol identifies important safety messages on MEWPs, safety signs in manuals or elsewhere. When you see this symbol, be alert to the possibility of personal injury or death. Follow the instructions in the safety message.

** DANGER**

---

**DANGER** indicates an imminently hazardous situation which, if not avoided, will result in death or serious injury.

---

** WARNING**

---

**WARNING** indicates a potentially hazardous situation which, if not avoided, could result in death or serious injury.

---

** CAUTION**

---

**CAUTION** indicates a potentially hazardous situation which, if not avoided, may result in minor or moderate injury. It may also be used to alert against unsafe practices.

---

**IMPORTANT**

**IMPORTANT** indicates a procedure essential for safe operation and which, if not followed, may result in a malfunction or damage to the MEWP.



---

# Table of Contents

<b>Section 1 – Scheduled Maintenance</b> .....	<b>9</b>
<b>1.1 Read and Heed</b> .....	<b>9</b>
1.1-1 <i>Mobile Elevating Work Platform (MEWP) definition</i> .....	9
1.1-2 <i>Purpose of Equipment</i> .....	9
1.1-3 <i>Use of Equipment</i> .....	9
1.1-4 <i>Service Policy and Warranty</i> .....	9
1.1-5 <i>Ownership of MEWP</i> .....	9
1.1-6 <i>Optional equipment</i> .....	9
<b>1.2 Maintenance and Inspection Schedule</b> .....	<b>10</b>
1.2-1 <i>Owner's Annual Inspection Record</i> .....	10
1.2-2 <i>Replacement Parts</i> .....	10
1.2-3 <i>Maintenance and Service Safety Tips</i> .....	10
1.2-4 <i>Hydraulic System &amp; Component Maintenance and Repair</i> .....	11
1.2-5 <i>Maintenance Hints</i> .....	12
1.2-6 <i>About this Section</i> .....	13
1.2-7 <i>Maintenance Instructions</i> .....	13
<b>1.3 Owner's Annual Inspection Record</b> .....	<b>14</b>
<b>1.4 Frequent/Periodic/Annual/Pre-Delivery Inspection Checklist</b> .....	<b>15</b>
<b>1.5 General inspections</b> .....	<b>16</b>
1.5-1 <i>Service Bulletins (B)</i> .....	16
1.5-2 <i>Annual Inspections (B)</i> .....	16
1.5-3 <i>Labels (B)</i> .....	16
1.5-4 <i>Pothole protection limit switches(B)</i> .....	16
<b>1.6 Base inspection</b> .....	<b>17</b>
<b>1.7 Scissors inspection</b> .....	<b>22</b>
<b>1.8 Platform inspection</b> .....	<b>26</b>
<b>1.9 Function Tests</b> .....	<b>27</b>
<b>Section 2 – Maintenance Tables and Diagrams</b> .....	<b>29</b>
<b>2.1 Standard Hose Numbering System</b> .....	<b>29</b>
<b>2.2 Torque Specifications for Fasteners (US)</b> .....	<b>31</b>
<b>2.3 Torque Specifications for Fasteners (Metric)</b> .....	<b>32</b>
<b>2.4 Torque Specifications for Hydraulic Couplings &amp; Hoses</b> .....	<b>33</b>
<b>2.5 Specifications &amp; Features - ANSI/CSA</b> .....	<b>34</b>
<b>2.6 Specifications &amp; Features - CE</b> .....	<b>35</b>
<b>2.7 Specifications &amp; Features - AS</b> .....	<b>36</b>
<b>2.8 Specifications &amp; Features - KC</b> .....	<b>37</b>

2.9	Maximum Platform Capacities (Evenly Distributed)	38
2.10	Floor Loading Pressure	39
2.11	Torque Specifications	40

**Section 3 – System Component Identification and Schematics . . . . . 41**

3.1	Electrical Symbol Chart	42
3.2	Hydraulic Symbol Chart	43
3.3	Wire Number and Color Code	44
3.4	Hydraulic Parts List	45
3.5	Electrical Parts List	46
3.6	Platform Control Box Wiring	48
3.7	Platform Control Box Wiring - SGLE	49
3.8	Base to Platform Control Cable	50
3.9	Base Control Wiring	51
3.10	Emergency Lowering Switch Wiring	52
3.11	Pothole Limit Switch Wiring	53
3.12	Holding Valve and Pressure Transducer Harnesses	54
3.13	Battery Management System Harness	55
3.14	Anti-Overriding Limit Switch Wiring (KC Only)	56
3.15	Anti-Overriding Limit Switch Harness (KC Only)	57
3.16	Free-Wheeling Manifold MB2	58
3.17	Brake Manifold MB4 (CE, AS & KC)	58
3.18	Lift Cylinder Manifold MB3	59
3.19	Major Component Identification	61
3.20	Main Manifold MB1	62
3.21	Hydraulic Schematics - SJ3215 ANSI/CSA	63
3.22	Hydraulic Schematics - SJ3215 CE, AS & KC	64
3.23	Hydraulic Schematics - SJ3219 ANSI/CSA	65
3.24	Hydraulic Schematics - SJ3219 CE	66
3.25	Hydraulic Schematics - SJ3219 AS & KC	67
3.26	Elevate Telematics Harness	68
3.27	Electrical Schematic - ANSI/CSA	69
3.28	Electrical Schematic - CE	70
3.29	Electrical Schematic - AS	71
3.30	Electrical Schematic - KC	72

**Section 4 – Troubleshooting Information . . . . . 76**

4.1	Introduction	76
4.2	Electrical System	77
4.2-1	All Controls Inoperative	77
4.2-2	All Controls Except for Down Function Inoperative	79
4.2-3	All Controls Inoperative From Base Control Console	80
4.2-4	No Up Function from Base Control Console	81

4.2-5	No Down Function from Base Control Console	82
4.2-6	No Emergency Down Function from Base Control Console*	83
4.2-7	All Controls Inoperative From Platform Control Console	84
4.2-8	No Up Function from Platform Controls (ANSI/CSA, CE, and AS)	87
4.2-9	No Up Function from Platform Controls (KC)	88
4.2-10	No Down Function from Platform Controls	90
4.2-11	Right Steer Inoperative	91
4.2-12	Left Steer Inoperative	91
4.2-13	Forward Drive Function Inoperative	92
4.2-14	Reverse Drive Function Inoperative	93
4.2-15	No Drive or Steer when Platform Elevated	95
4.2-16	Pressure Transducer PT1 Inoperative	95
4.2-17	Angle Transducer AT1 Inoperative	96
<b>4.3</b>	<b>Hydraulic System</b>	<b>97</b>
4.3-1	All Functions Inoperative	97
4.3-2	All System Sluggish	97
4.3-3	Platform Drifts Down	97
4.3-4	Platform Lifts Slowly	97
4.3-5	Platform Does Not Lift	97
4.3-6	Platform Will Not Lower	98
4.3-7	Platform Drives Slow	98
4.3-8	Platform Will Not Drive in Forward or Reverse	98
4.3-9	Brake(s) will not Release (Pin Brakes)	98
4.3-10	Brake(s) will not Release (Wet Brakes)	98
4.3-11	MEWP will not hold on a Grade (Wet Brakes)	99
4.3-12	Platform does not Steer	99
<b>Section 5 – Procedures</b>		<b>100</b>
<b>5.1</b>	<b>General</b>	<b>100</b>
5.1-1	Safety and Workmanship	100
<b>5.2</b>	<b>Platform</b>	<b>101</b>
5.2-1	Single Axis Joystick	101
5.2-2	Gate Spring Hinge Adjustment	102
5.2-3	Railing Maintenance and Repair	102
<b>5.3</b>	<b>Base</b>	<b>104</b>
5.3-1	System Relief Pressure Adjustment	104
5.3-2	Pothole Compression Rod Replacement	105
5.3-3	Pothole Limit Switches (LS1 & LS2) Replacement and Adjustment	106
5.3-4	Pothole Bar Replacement/Removal for Servicing	108
5.3-5	Tightening and Torque Recommendations for Hydraulic Couplings and Hoses	110
5.3-6	Integrated Hub Wheel Removal and Installation	112
5.3-7	Battery Maintenance	116
5.3-8	Charger Maintenance	116

---

<b>5.4</b>	<b>Skycoded Module</b>	<b>123</b>
5.4-1	Skycoded Control Module (CM1)	123
5.4-2	Calibration and Diagnostic Tool Key Functions	126
5.4-3	Diagnostics, Help Messages and Flash Codes	141
5.4-4	Override Mode Procedure	148
5.4-5	Initial Set-up and Change Defaults Procedure	148
5.4-6	Access Levels Procedure	149
5.4-7	Calibrate Level Procedure	149
5.4-8	Calibrate Load Procedure	150
5.4-9	Language Setting Procedure	152
5.4-10	Callibration Fault Codes	153



---

# Section 1 – Scheduled Maintenance

## 1.1 Read and Heed

Skyjack is continuously improving and expanding product features on its equipment; therefore, specifications and dimensions are subject to change without notice.

### 1.1-1 Mobile Elevating Work Platform (MEWP) definition

A mobile machine intended for moving persons, tools, and material to working positions, consisting of a work platform with controls, an extending structure, and a chassis.

### 1.1-2 Purpose of Equipment

The Skyjack SJ DC Electric Scissor lifts are designed to move personnel, tools, and materials to working positions.

### 1.1-3 Use of Equipment

The MEWP is a highly maneuverable, mobile work station. Work platform elevation and elevated driving must only be done on a firm, level surface.

### 1.1-4 Service Policy and Warranty

Skyjack warrants each new product to be free of defective parts and workmanship for the first 2 years or 3000 hours, whichever occurs first. Any defective part will be replaced or repaired by your local Skyjack dealer at no charge for parts or labor. In addition, all products have a 5-year structural warranty. Contact the Skyjack Service Department for warranty statement extensions or exclusions.

### 1.1-5 Ownership of MEWP

Notify Skyjack of MEWP ownership. If you sell or transfer the ownership of a MEWP, promptly notify Skyjack of the new owner's contact information.

Skyjack needs this information to inform the owner of any updates or additional activities that are necessary to keep the machine in proper working condition.

### 1.1-6 Optional equipment

This MEWP is designed to accept a variety of optional accessories. Refer to *operation manual* for a list of the optional accessories. Operating instructions for these options are in the operation manual.

For components or systems that are not standard, speak to the Skyjack Service Department. Give the model and serial number for each applicable MEWP.

## 1.2 Maintenance and Inspection Schedule

The actual operating environment of the work platform governs the use of the maintenance schedule. The inspection points covered in [1.4 Frequent/Periodic/Annual/Pre-Delivery Inspection Checklist](#), indicates the areas of the MEWP to be maintained or inspected and at what intervals the maintenance and inspections are to be performed.

### 1.2-1 Owner's Annual Inspection Record

It is the responsibility of the owner to arrange quarterly and annual inspections of the MEWP. [1.3 Owner's Annual Inspection Record](#). Owner's Annual Inspection Record is to be used for recording the date of the inspection, owner's name, and the person responsible for the inspection of the work platform.

### 1.2-2 Replacement Parts

Use only original replacement parts. Parts such as batteries, wheels, railings, etc. with weight and dimensions different from original parts will affect stability of the MEWP and must not be used without manufacturer's consent.

All replacement tires must be of the same size and load rating as originally supplied tires; to maintain safety and stability of MEWP.

Consult SKYJACK's Service Department for optional tires specifications and installation.

### **WARNING**

**Any unit that is damaged or not operating properly must be immediately tagged and removed from service until proper repairs are completed.**

### 1.2-3 Maintenance and Service Safety Tips

Maintenance and repair should only be performed by personnel who are trained and qualified to service this MEWP.

All maintenance and service procedures should be performed in a well lighted and well ventilated area.

Anyone operating or servicing this MEWP must read and completely understand all operating instructions and safety hazards in this manual and operating manual.

All tools, supports and lifting equipment to be used must be of proper rated load and in good working order before any service work begins. Work area should be kept clean and free of debris to avoid contaminating components while servicing.

Make sure personnel are clear from under unsupported components/systems that are at risk of movement during maintenance.

All service personnel must be familiar with employer and governmental regulations that apply to servicing this type of equipment.

Keep sparks and flames away from all flammable or combustible materials.

Properly dispose of all waste material such as lubricants, rags, and old parts according to the relative law provisions obtaining in the country.

Before attempting any repair work, disconnect the main power connectors.

Keep personnel clear of components, systems or unsupported loads that may move unexpectedly during maintenance procedures.

Preventive maintenance is the easiest and least expensive type of maintenance.

## 1.2-4 Hydraulic System & Component Maintenance and Repair

The following points should be kept in mind when working on the hydraulic system or any component:

### **WARNING**

**Escaping fluid from a hydraulic pressure leak can damage your eyes, penetrate the skin and cause serious injury. Use proper personal protection at all times.**

1. Any structure has limits of strength and durability. To prevent failure of structural parts of hydraulic components, relief valves which limit pressure to safe operating values are included in the hydraulic circuits.
2. Tolerance of working parts in the hydraulic system is very close. Even small amounts of dirt or foreign materials in the system can cause wear or damage to components, as well as general faulty operation of the hydraulic system. Every precaution must be taken to assure absolute cleanliness of the hydraulic oil.
3. Whenever there is a hydraulic system failure which gives reason to believe that there are metal particles or foreign materials in the system, drain and flush the entire system and replace the filter cartridges. A complete change of oil must be performed under these circumstances.
4. Whenever the hydraulic system is drained, check the magnets in the hydraulic reservoir for metal particles. If metal particles are present, flush the entire system and add a new change of oil. The presence of metal particles also may indicate the possibility of imminent component failure. A very small amount of fine particles is normal.
5. All containers and funnels used in handling hydraulic oil must be absolutely clean. Use a funnel when necessary for filling the hydraulic oil reservoir, and fill the reservoir only through the filter opening. The use of cloth to strain the oil should be avoided to prevent lint from getting into the system.
6. When removing any hydraulic component, be sure to cap and tag all hydraulic lines involved. Also, plug the ports of the removed components.



### **NOTE**

*Samples of hydraulic oil should be drawn from the reservoir and tested annually. These samples should be taken when the oil is warmed through normal operation of the system. The sample should be analyzed by a qualified lubrication specialist to determine if it is suitable for continued use. Oil change intervals will depend on the care used in keeping the oil clean, and the operating conditions. Dirt and/or moisture contamination will dictate that the oil should be changed more often. Under normal use and operating conditions, the hydraulic oil should be changed every two years. Refer to [Table 1.4 Frequent/Periodic/Annual/Pre-Delivery Inspection Checklist](#) of this manual.*

7. All hydraulic components must be disassembled in spotlessly clean surroundings. During disassembly, pay particular attention to the identification of parts to assure proper reassembly. Clean all metal parts in a clean mineral oil solvent. Be sure to thoroughly clean all internal passages. After the parts have been dried thoroughly, lay them on a clean, lint-free surface for inspection.
8. Replace all O-rings and seals when overhauling any component. Lubricate all parts with clean hydraulic oil before reassembly. Use small amounts of petroleum jelly to hold O-rings in place during assembly.
9. Be sure to replace any lost hydraulic oil when completing the installation of the repaired component, and bleed any air from the system when required.
10. All hydraulic connections must be kept tight. A loose connection in a pressure line will permit the oil to leak out or air to be drawn into the system. Air in the system can cause damage to the components and noisy or erratic system operation.

### 1.2-5 Maintenance Hints

Three simple maintenance procedures have the greatest effect on the hydraulic system performance, efficiency and life. Yet, the very simplicity of them may be the reason they are so often overlooked. They are simply these:

1. Change filters annually. The filters will need to be changed more often depending on the operating conditions. Dirty, dusty, high moisture environments may cause the hydraulic system to be contaminated more quickly.
2. Maintain a sufficient quantity of clean hydraulic oil of the proper type and viscosity in the hydraulic reservoir.
3. Keep all connections tight.

### 1.2-6 About this Section

This section contains the maintenance and inspection schedule that is to be performed.

References are made to the procedures in Section 5 that outline detailed step-by-step instructions for checks and replacements.

#### Service Bulletins

Before performing any scheduled maintenance inspection procedure, refer to service bulletins found in our web site: [www.skyjack.com](http://www.skyjack.com) for updates related to service and maintenance of this MEWP.

#### Maintenance and Inspection

Death or injury can result if the MEWP is not kept in good working order. Inspection and maintenance should be performed by competent personnel who are trained and qualified on maintenance of this MEWP.

#### WARNING

**Failure to perform each procedure as presented and scheduled may cause death, serious injury or substantial damage.**

#### NOTE

*Preventive maintenance is the easiest and least expensive type of maintenance.*

- Unless otherwise specified, perform each maintenance procedure with the MEWP in the following configuration:
  - MEWP parked on a flat and level surface
  - Disconnect the batteries by disconnecting the main power connectors.
- Repair any damaged or malfunction components before operating MEWP.
- Keep records on all inspections.

### 1.2-7 Maintenance Instructions

This manual consists of four schedules to be done for maintaining on an MEWP. Inspection schedule frequency is shown below:

#### Task Frequency















PDI/Frequent/Periodic	<b>B</b>	Perform PDI prior to each delivery, or Frequent Inspection every 200 days or 200 hours.
Annual	<b>C</b>	Perform Scheduled Maintenance Inspections every year.
Additional	<b>*</b>	Perform at time sensitive maintenance intervals.

- Make copies of the maintenance and inspection checklist to be used for each inspection.
- Check the schedule on the checklist for the type of inspection to be performed.
- Place a check in the appropriate box after each item meets the inspection requirements.
- Use the maintenance and inspection checklist and step-by-step procedures in Section 1 to perform these inspections.
- If any inspection receives a fail, tag and remove the MEWP from service.
- If any MEWP component(s) has been repaired, an inspection must be performed again before removing the tag. Place a check in the repair column.

#### Legend

Pass	<b>P</b>
Not applicable	<b>N/A</b>

**Table 1.3 Owner's Annual Inspection Record**

 Model _____ SN _____											
 Inspection Date											
 Inspector Signature											

**⚠ WARNING**

Do not use the MEWP if there is no inspection recorded in the last 13 months. If you do not obey, there is a risk of death or serious injury.

**IMPORTANT**

The Owner's annual inspection record is located on the scissor assembly. It must be filled out after an annual inspection has been completed. Do not use the MEWP if an inspection has not been recorded in the last 13 months.

# 1.4 Frequent/Periodic/Annual/Pre-Delivery Inspection Checklist

## SKYJACK Frequent/Periodic/Annual/PDI Checklist Vertical Mast, Electric Scissor, Micro Scissor & Rough Terrain

Serial Number: Starting with serial number A/B000 000 000 or 09 000 000 and above

Product Owner: \_\_\_\_\_

Model: \_\_\_\_\_

Product User: \_\_\_\_\_

Hourmeter Reading: \_\_\_\_\_

Date/Time: \_\_\_\_\_

Inspection Type (Choose one): Pre-delivery    Frequent    Periodic    Annual

**Use this table for pre-delivery inspections (PDI) before each rental, lease or sale and as an instruction for all frequent inspections and annual inspections. Refer to the operation and service manuals for inspection instructions (for example, visual inspection and function tests, torque specs, engine oil, chain inspection intervals, and more).**

Inspection Type Schedule	
PDI/Frequent/Periodic	B
Annual	B+C

**B** - Do the pre-delivery inspection before the machine is sent out or during the frequent inspections at 200 days or 200 hour intervals. For more instructions, refer to the operation and service manuals. **P** - Pass  
**C** - Do the scheduled maintenance Inspections each year. For more instructions, refer to the operation and service manuals. **N/A** - Not Applicable

Put a check mark on the "Pass" column as you meet the requirements of the inspection of each item. Add a comment if the item does not pass inspection.

Items for Inspection	P	N/A
<b>Service Bulletins.</b> Make sure there are no open service bulletins.	B	
<b>Annual Inspection.</b> Make sure you complete it within 13 months.	B	
<b>Labels.</b> In place, correctly attached & you can read them.	B	
<b>Limit Switches.</b> Correctly installed & no obstructions or damage.	B	
<b>BASE/ENGINE</b>		
<b>Engine and Components.</b> Do a check on engine and components for any loose, missing, damaged, or failed items. Make sure you do not exceed the recommended fluid, oil and coolant change intervals.	B	
<b>Engine and Components.</b> Replace the engine oil and filter.	C	
<b>Engine Intake Air Filter.</b> No damage or missing component. Remove dirt & dust.	B	
<b>Engine Intake Air Filter.</b> Replace the air filter if necessary.	C	
<b>Engine Oil.</b> Oil level between "L" and "H". Make sure you do not exceed the oil change interval.	B	
<b>Radiator.</b> Correctly attached & no damage or missing components. Do a check of coolant level.	B	
<b>Radiator.</b> Do a check of coolant level & condition & replace if necessary.	C	
<b>Fuel Tank &amp; Lines.</b> Filler cap, tank, fittings and hoses are tightly closed & no damage or leaks.	B	
<b>Propane Tank &amp; Lines.</b> Straps are correctly installed to brackets & couplers are tight. Make sure there are no damage or leaks.	B	
<b>Outriggers.</b> No damage or missing components.	B	
<b>Pothole Protection.</b> Both sides have no obstructions, dirt or damage.	B	
<b>Battery/Hydraulic Tray.</b> Trays are latched tightly & no missing components.	B	
<b>Batteries.</b> No damage, tight connections & sufficient fluid levels. Clean terminals and cable ends.	B	
<b>Battery Charger.</b> Correctly attached & no damage.	B	
<b>Steer Assembly.</b> Correctly attached & no damage leaks or missing components.	B	
<b>Wheel/Tire Assembly.</b> Do a check of all tires for damage, wear & correctly aligned.	B	
<b>Wheel/Tire Assembly.</b> Wheel nuts torqued as recommended.	C	
<b>Axles.</b> Correctly attached & no missing components. Tight fittings and hoses & no leaks.	B	
<b>Axles.</b> Do a check and replace oil if necessary.	C	
<b>Hydraulic Tank, Pump, Motor &amp; Lines.</b> Filler cap, hoses, and other hydraulic components are closed tightly & no damage or leaks.	B	
<b>Hydraulic Oil.</b> Level at, or slightly above top mark.	B	
<b>Hydraulic Oil.</b> Do a check and replace oil and filters if necessary.	C	
<b>Electrical Components.</b> Do a check on all electrical components such as the motor controller if necessary. Correctly attached & no damage. Tight wire connections and fasteners.	B	

Items for Inspection	P	N/A
<b>Manifolds.</b> Tight fittings and hoses & no damage or leaks. Tight wire connections, no missing components & correctly working valves.	B	
<b>Main Power Disconnect Switch.</b> Cables tight & in working order.	B	
<b>Base Controls.</b> Operate switches and make sure they all operate correctly. No damage or missing components.	B	
<b>Brakes.</b> Correctly attached & no damage or leaks.	B	
<b>Brakes.</b> Do a check on disc wear and replace if necessary.	C	
<b>Base Weldment.</b> No deformation or cracks.	B	
<b>Grease Points.</b> No obstructions, dirt, or damage. Add grease if necessary.	B	
<b>Ladder.</b> Correctly attached & no damage.	B	
<b>Tilt Sensor.</b> Correctly attached & no damage.	B	
<b>LIFTING MECHANISM - MAST/SCISSORS</b>		
<b>Maintenance Support(s).</b> Correctly attached & no damage.	B	
<b>Scissor Assembly &amp; Bumpers.</b> Correctly attached, no deformation/damage. Cables & wires installed with no damage.	B	
<b>Sliders &amp; Rollers.</b> Correctly attached & no obstructions, dirt, or damage/wear.	B	
<b>Lift Cylinder(s).</b> No damage or missing components. Tight fittings and hoses & no leaks. Correctly installed.	B	
<b>Angle Transducer.</b> Correctly attached & no damage.	B	
<b>Scissor Pins.</b> Correctly attached & no damage.	B	
<b>Mast Assembly.</b> No damage, cracks or deformation.	B	
<b>Mast Assembly.</b> Lubricate the mast as recommended.	C	
<b>Chains, Rollers &amp; Control Cables.</b> No damage or missing components.	B	
<b>Wear Pads.</b> No damage/wear or missing components. Fasteners tight.	B	
<b>PLATFORM</b>		
<b>Railings and Gate.</b> Correctly attached & no damage or missing components.	B	
<b>Fall-Protection Anchorage.</b> Attachment rings correctly attached & no damage.	B	
<b>AC Power Socket.</b> No obstructions, dirt, or damage.	B	
<b>Platform Control Console.</b> Operate the switches and make sure they all operate correctly. No damage or missing components.	B	
<b>Manual Storage Box.</b> Manuals and documents are in the storage the box, in good condition, and you can read them.	B	
<b>Powered Extension Control Console.</b> Operate switches and make sure they all operate correctly. No damage or missing components.	B	
<b>Extension Platform.</b> Correctly attached & no damage or missing components.	B	
<b>Function Tests.</b> Refer to the operation manual for your serial number for information on how to run these tests.	PASS	
	FAIL	

Comments: \_\_\_\_\_

199341ACA

The undersigned has made sure that all areas in the list have received an inspection.  
 The undersigned has told the machine owner of all inconsistencies in the inspection and corrected them before machine operation.

Owner: \_\_\_\_\_ Print Name \_\_\_\_\_ Signature \_\_\_\_\_ Date (DD/MM/YY) \_\_\_\_\_

User: \_\_\_\_\_ Print Name \_\_\_\_\_ Signature \_\_\_\_\_ Date (DD/MM/YY) \_\_\_\_\_



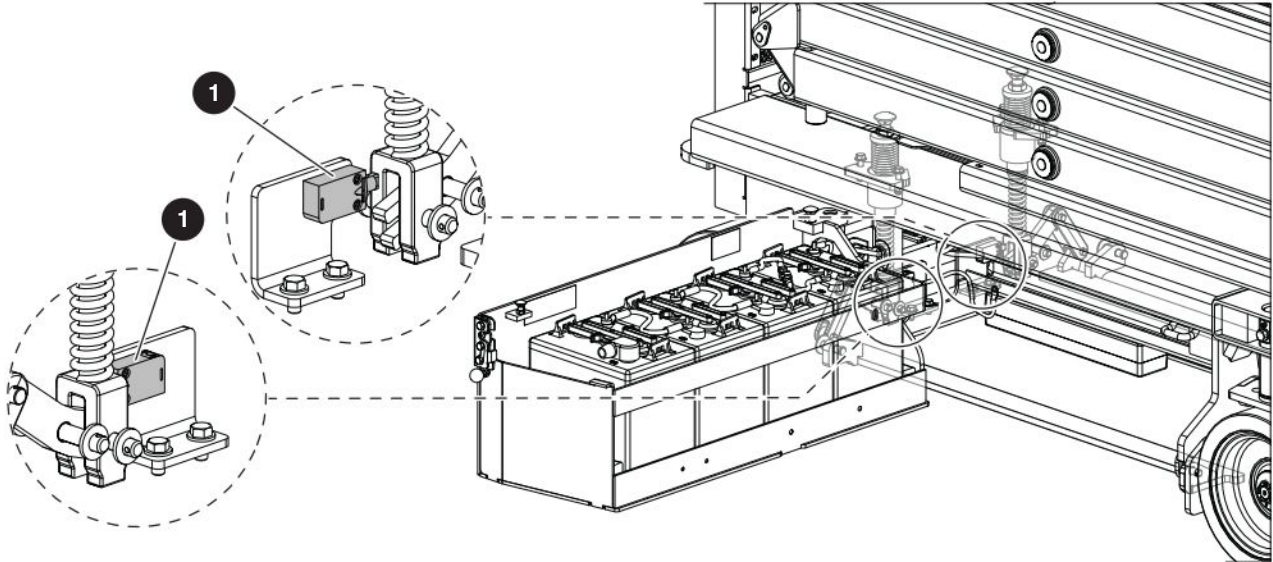

## 1.5 General inspections

Do an inspection of the MEWP in this sequence:

### **⚠ WARNING**

Do not operate a MEWP that does not function correctly. Lock and tag the MEWP, and remove it for servicing. Only a qualified service technician must repair the MEWP. If you do not obey, there is a risk of death or serious injury.

### **⚠ WARNING**

Turn the main power disconnect switch to the off position before you do the visual and daily maintenance inspections. If you do not obey, there is a risk of death or serious injury.

### **⚠ CAUTION**

Make sure that the MEWP is on a firm, level surface before you do the visual and daily maintenance inspections. If you do not obey, there is a risk of machine damage.

### 1.5-1 Service Bulletins (B)

Go to [www.skyjack.com](http://www.skyjack.com) and use your machine's serial number to find related open service bulletins.

### 1.5-2 Annual Inspections (B)

Do a check on the machine's service record to find information about previous service performed.

### 1.5-3 Labels (B)

Refer to the operation manual for the labels. Make sure all the labels are in the correct location, are in good condition, and you can read them.

### 1.5-4 Pothole protection limit switches (B)

Make sure the pothole protection limit switches **1** are correctly attached, there is no visible damage, and the movement is not blocked.



Example model SJ3219 Battery Tray

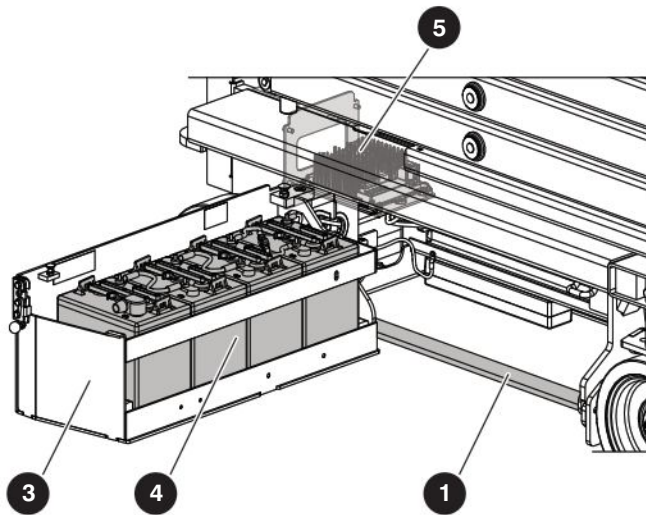

Example model SJ3219 Hydraulic Tray

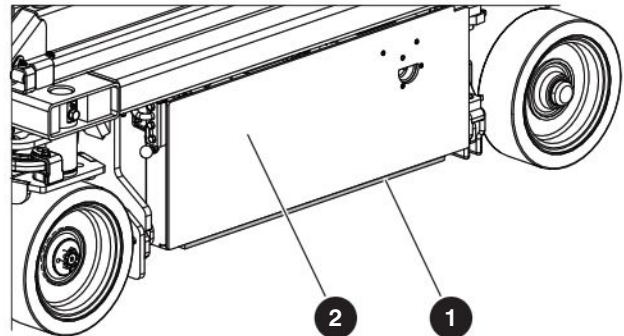

## 1.6 Base inspection

### 1 Pothole protection device (B)

- Make sure there are no loose or missing parts.
- Make sure there is no visible damage.
- Make sure there is no dirt and blockages.

### 2 Hydraulic and electric tray (B)

- Make sure that the hydraulic and electric tray latches correctly and is in good condition.

### 3 Battery tray (B)

- Make sure that the battery tray latches correctly and is in good condition.

### 4 Batteries (B)

#### **⚠ WARNING**

Explosion hazard. Keep flames and sparks away. Do not smoke near the batteries. Batteries release explosive gas while you charge them. Charge the batteries in a well-ventilated area. If you do not obey, there is a risk of death or serious injury.

#### **⚠ WARNING**

Corrosion hazard. Do not touch battery acid. Wear the correct PPE. If the battery acid touches you, immediately flush the area with cold water and get medical aid.

1. Do an inspection of the battery case for damage.

2. Make sure all the battery connections are tight.

3. Clean the battery terminals and cable ends thoroughly with a terminal cleaning tool or wire brush.

4. If applicable, do a check on the battery fluid levels. If the plates do not have a minimum 13 mm (1/2 inch) of solution above them, add distilled or demineralized water.

5. Replace the battery if damaged or not able to hold a lasting charge.

#### **⚠ WARNING**

Only use original or manufacturer-approved parts and components for the MEWP. If you do not obey, there is a risk of death, serious injury, or machine damage.

### 5 Battery charger (B)

- Make sure that the battery charger is correctly installed, and in good condition.
- Make sure there is no visible damage.

Example model SJ3219

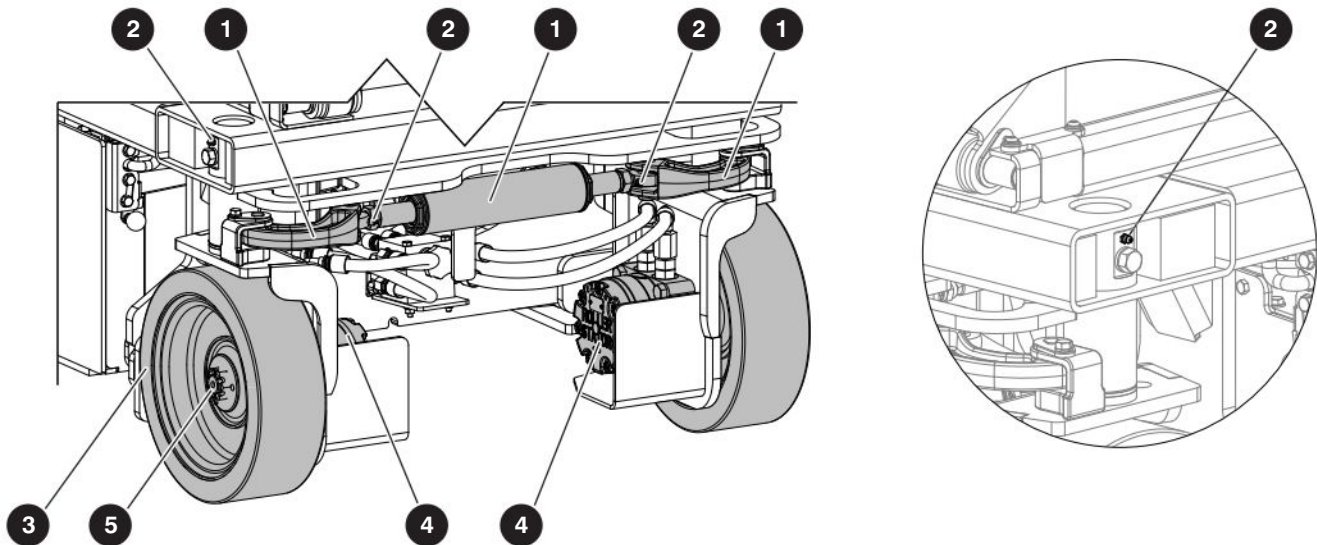

### 1 Steer assembly (B)

#### ▪ Steer cylinder assembly (B)

- Make sure that the steer cylinder assembly is correctly installed.
- Make sure there are no loose or missing fasteners.
- Make sure there is no visible damage.

#### ▪ Steer linkages (B)

- Make sure there are no loose or missing fasteners and lock-pins.
- Make sure that the steer linkages and bushings are correctly attached.
- Make sure there is no visible damage.

### 2 Grease points (B)

- Make sure there are no loose or missing fasteners and lock-pins.
- Make sure that the steer linkages and bushings are correctly attached.
- Make sure there is no visible damage.
- Add grease if necessary.

### 3 Wheel/tire assembly (B, C)

A small amount of wear is permitted. But if any of the wear or damage meets the criteria mentioned below, the tire should be replaced.

### **⚠ WARNING**

**Do not use tires other than the tires that Skyjack specifies for this MEWP. Do not mix different types of tires or use tires that are not in good condition. Only replace the tires with the same types that are approved by Skyjack. The use of other tires can make the MEWP less stable. If you do not obey, there is a risk of death or serious injury.**

The tire treads have been removed from the illustration for clarity.

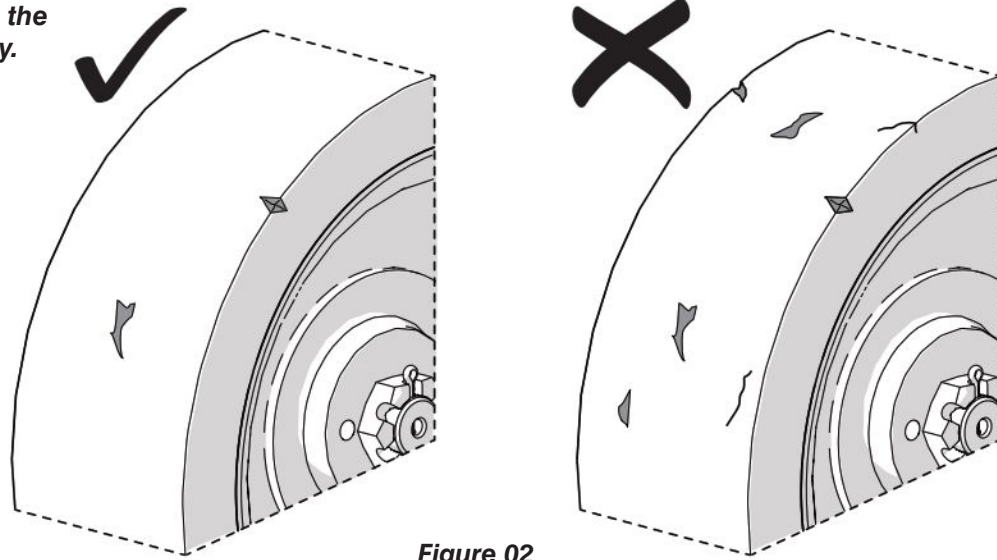

Figure 02

▪ **B - Frequent/periodic/pre-delivery inspection**

Do a check for damage or wear on each tire and rim.

- Look for damage or cracked welds on each rim. The rims should be round.
- Look for uneven or unusual wear on the tire.
- Look for flat spots on the tread face of the tire.
- The tire tread should be visible and not worn down completely. Refer to Figure 01.

Do a check for cuts or missing chunks in the edges and tread face of the tire. Refer to Figure 02.

- The cut or missing chunk must not extend more than 10 mm (3/8") towards the centre of the tire.
- Each cut or chunk should not be larger than 25 mm x 10 mm (1" x 3/8"), or deeper than 20 mm (3/4").
- There should be no more than 2 cuts or chunks in each 1/4 section of the tire. There must be no more than 6 cuts or chunks in total in the tire.
- There should be no embedded debris.

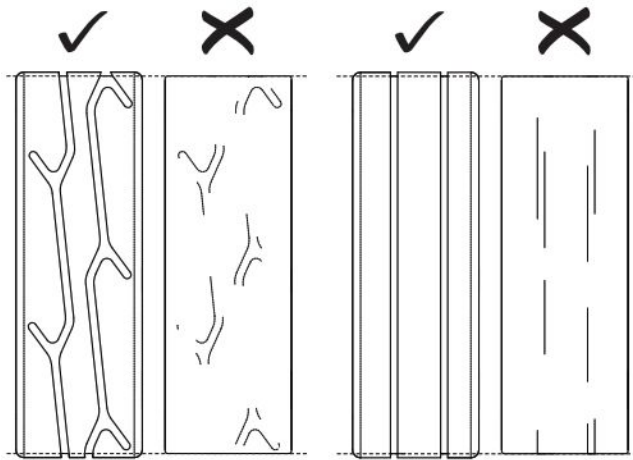

Figure 01

Do a check of the wheel components and mounts.

- Make sure the wheels are correctly aligned vertically and horizontally.
- Make sure the **wheel motors** ④ have no loose or missing parts and there is no visible damage.
- **C - Annual inspection**
  - Make sure the **castle nuts** ⑤ are in position and are tight.
  - Make sure the **cotter pins** are correctly installed.
  - If the cotter pin is not installed, refer to [2.11 Torque Specifications](#) for proper torque information.

Example model SJ3219 ANSI/CSA

SJ3219 CE, AS &amp; KC Manifolds

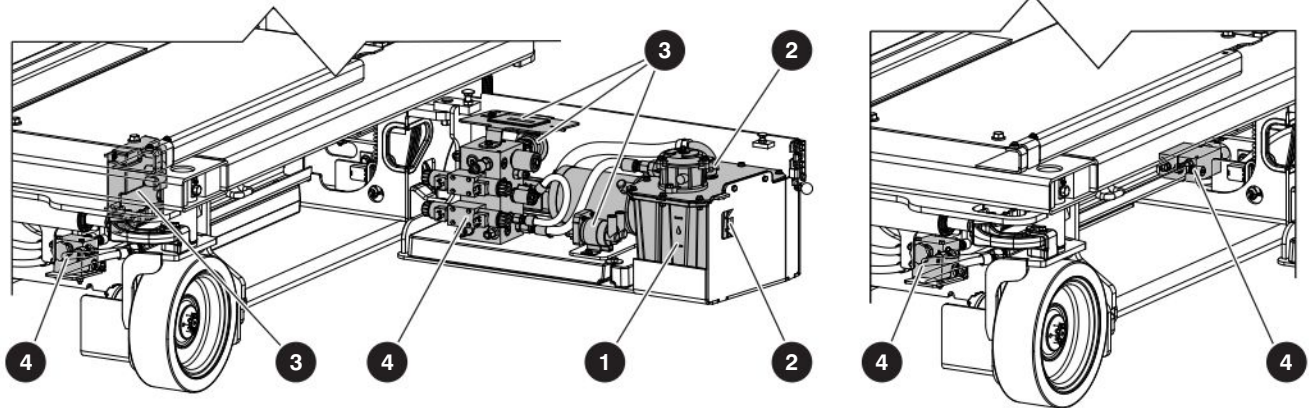

### 1 Hydraulic tank (B)

- Make sure the hydraulic filler cap closes tightly.
- Make sure there is no visible damage or hydraulic leaks.

### 2 Hydraulic oil level (B, C)

- **B - Frequent/periodic/pre-delivery inspection**
  - Fully lower the platform.
  - Do a check on the gauge on the left side of the hydraulic oil tank. The hydraulic oil level must be at or a small distance above the top mark of the gauge.
- **C - Annual inspection**
  - Do a check of the hydraulic oil for contamination and make sure the filter is in good condition.
  - Replace the hydraulic oil and filters if necessary.

### 3 Electrical components (B)

- Do a check on these areas for chafed, corroded, and loose wires:
  1. Base to platform cables and wiring harness
  2. Battery tray wiring harnesses
  3. Hydraulic and electrical wiring harnesses.
- **Skycoded™ display panel (B)**
  - Make sure the panel is correctly attached, and there is no visible damage.
- **Hydraulic pump and motor (B)**
  - Make sure there are no loose or missing fasteners.
  - Make sure there is no visible damage.

### ▪ Motor controller (B)

- Make sure the motor controller is correctly attached, and there is no visible damage.
- Make sure there are no loose wires or missing fasteners.

### ▪ Motor contactor (B)

- Make sure the motor contactor is correctly attached, and there is no visible damage.
- Make sure there are no loose wires or missing fasteners.

### ▪ Emergency lowering switch (B)

- Make sure the emergency lowering switch is correctly attached, and there is no visible damage.
- Make sure the toggle switch operates correctly.
- Make sure there are no loose wires or missing fasteners.

### 4 Manifolds (B)

- Make sure all fittings and hoses are correctly tightened.
- Make sure there is no indication of hydraulic leakage.
- Make sure there are no loose wires or missing fasteners.
- Make sure all the manual valves operate correctly and do not seize.

Example model SJ3219 ANSI/CSA

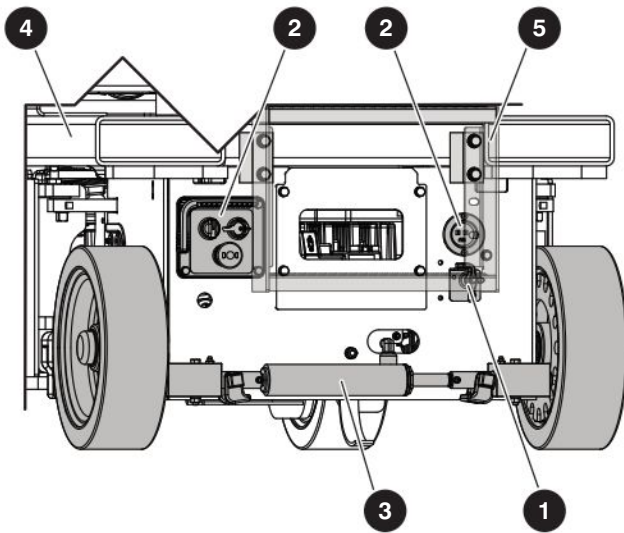

Example model SJ3219 CE, AS & KC

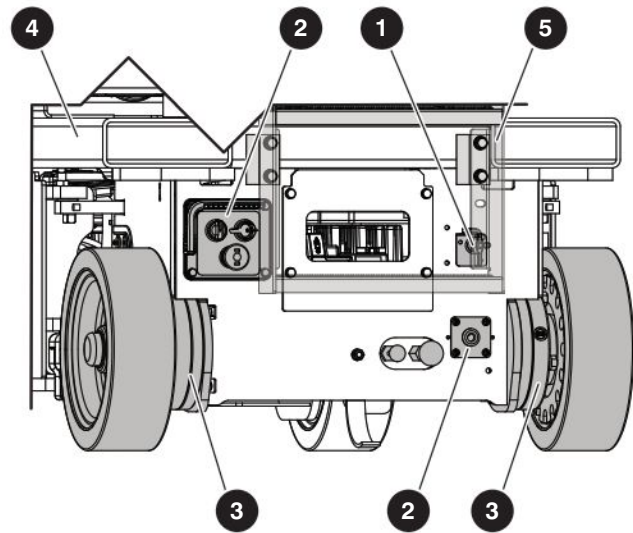

**1 Main power disconnect switch (B)**

- Turn the main power disconnect switch to the off position.
- Make sure the switch rotates and stays in the on and off position.
- Make sure the cables are not loose.

**2 Base control (B)**

- Make sure there is no visible damage, and all the switches operate correctly.

▪ **AC power socket (B)**

- Make sure there is no visible damage.

**3 Brakes (B, C)**

▪ **B - Frequent/periodic/pre-delivery inspection**

- Make sure there are no loose or missing fasteners.
- Make sure there is no visible damage.

▪ **C - Annual inspection**

- Make sure that the disc or pin brakes show no signs of wear and/or physical damage.
- Replace the disc or pin brakes if necessary.

**4 Base weldment (B)**

- Make sure that the base shows no signs of visible damage, deformation, or cracks in the weldments.

**5 Ladder (B)**

- Make sure there are no loose or missing parts.
- Make sure there is no visible damage.



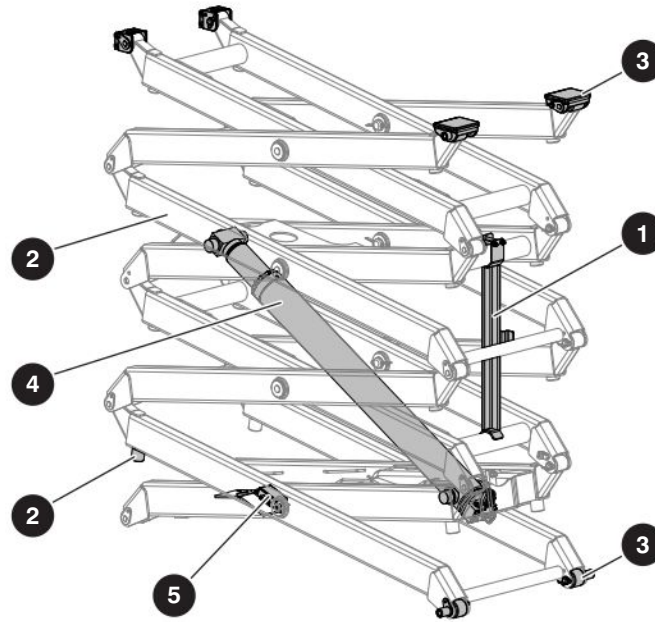

## 1.7 Scissors inspection

1. Raise the platform and deploy the maintenance supports.

### 1 Maintenance support (B)

- Make sure that the maintenance supports are correctly attached and show no visible damage.

### 2 Scissor assembly and bumpers (B)

- Make sure that the scissor assembly shows no signs of visible damage, deformation, or cracks in the weldments.
- Make sure all the pins and fasteners are correctly installed.
- Make sure that the cables and wires have the correct routing, and show no signs of wear and/or physical damage.
- Make sure that the bumpers are correctly attached and have no visible damage.

### 3 Sliders and rollers (B)

- Make sure that the sliders and rollers on the left and right side of the MEWP are correctly attached.
- Make sure there is no visible damage.
- Make sure there is no dirt or blockages in the slider's and roller's travel paths.

### 4 Lift cylinder (B)

- Make sure that the lift cylinders are correctly installed.
- Make sure there are no loose or missing fasteners.
- Make sure there is no indication of leaks or damage.

### 5 Angle transducer (B)

- Make sure that the angle transducer is correctly attached.

2. Fully lower the platform.

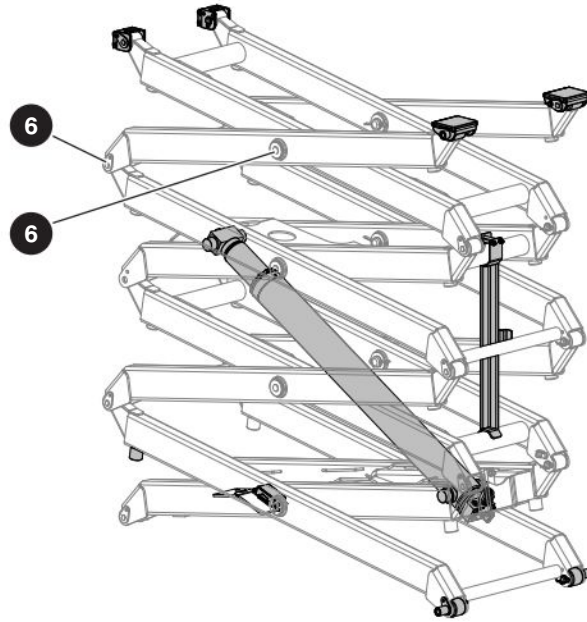

**6 Scissor pin inspection (B)**

**⚠ WARNING**

Units that show signs of damage must be immediately removed from service and repaired by a qualified technician. Speak to the Skyjack service department for directions on how to repair the unit.

1. Do an inspection of the scissor pin connections. Look for signs of damage on the pins and scissor arms. These signs can include:
  - Noise can be heard from seized pins.
  - Rust near the pin joint
  - Cracks in welds of adjacent metals
  - Dust or metal shaving from worn components
  - Broken or missing pin retainer bolts
  - Broken or missing pin retainers
  - Rotated pin
  - Elongated or enlarged pin hole
2. Remove damaged pins and bushings. Do an inspection of the scissor bore after removing the applicable pins and bushings. Look for signs of damage, elongation and ovality of the hole.
3. If there is no structural damage to the scissor arms, replace the pins and bushings with new components.

**Examples of pivot pin connections with no damage:**

- No rust
- Pin has not rotated
- Area is clear of dust or metal shavings
- Pin retainers are installed

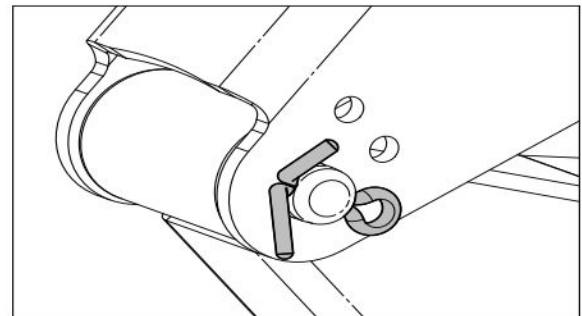
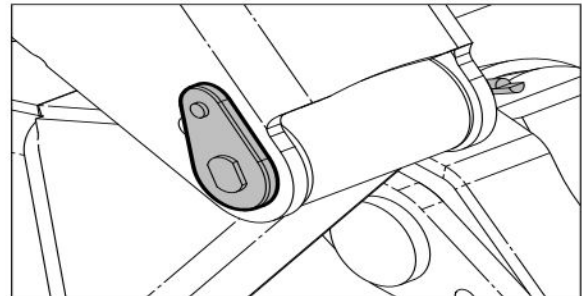

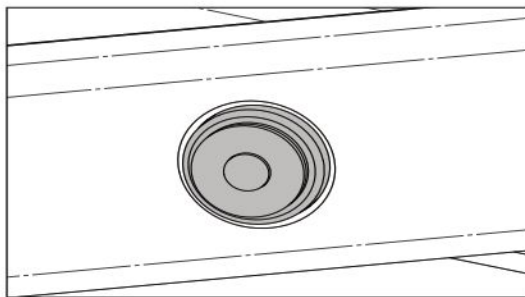
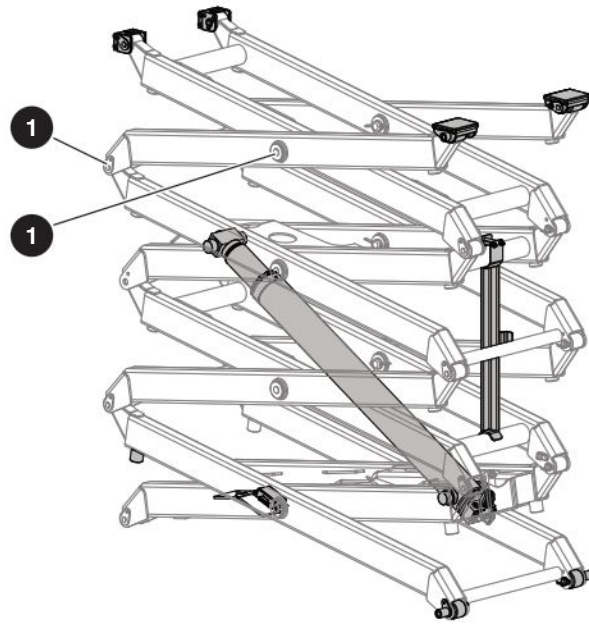

Center Pin - Outer

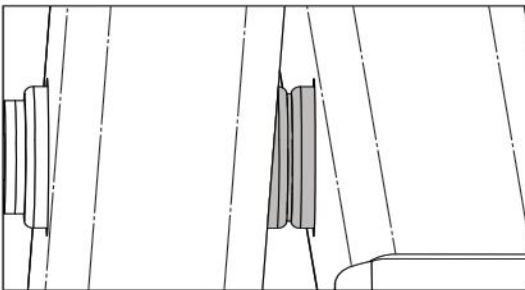

Center Pin - Middle

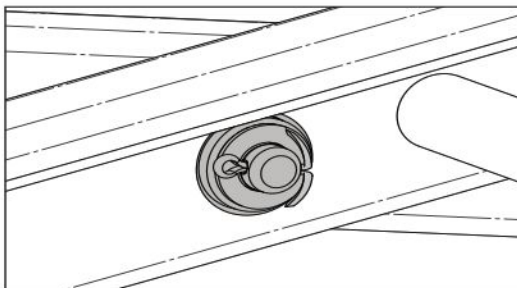

Center Pin - Inner

Examples of damaged pin connections:

Broken retainer bolt

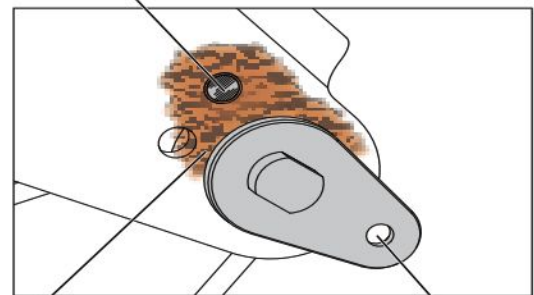

Rust around the pin

Rotated pin

Rust around pin boss

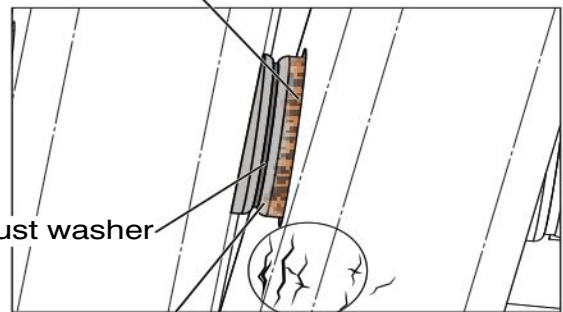

Thrust washer

Broken pin boss

Stress cracks



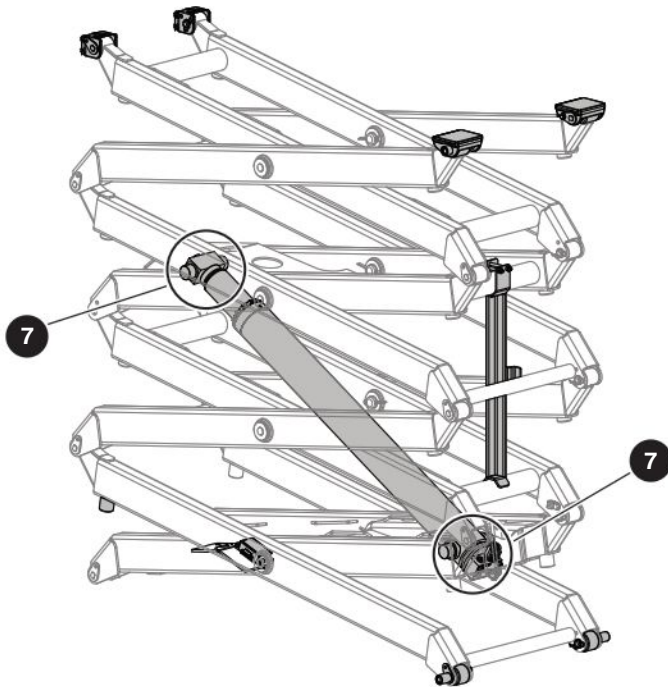

Upper cylinder mount area

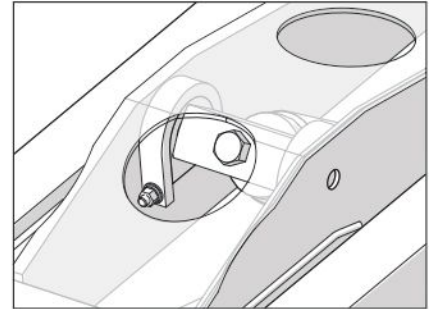

Lower cylinder mount area

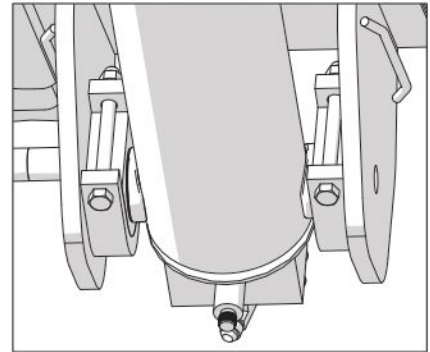

**7 Cylinder mount inspection (B)**

This inspection must be done as part of the scissor assembly inspection.

1. Do a structural inspection of the cylinder mount areas. Look for signs of damage to the mounts.

1. These signs can include:

- Broken, loose or missing retainers or bolts
- Bearing block degradation
- Cracks in welds or the surrounding metal, or rust forming in the area.

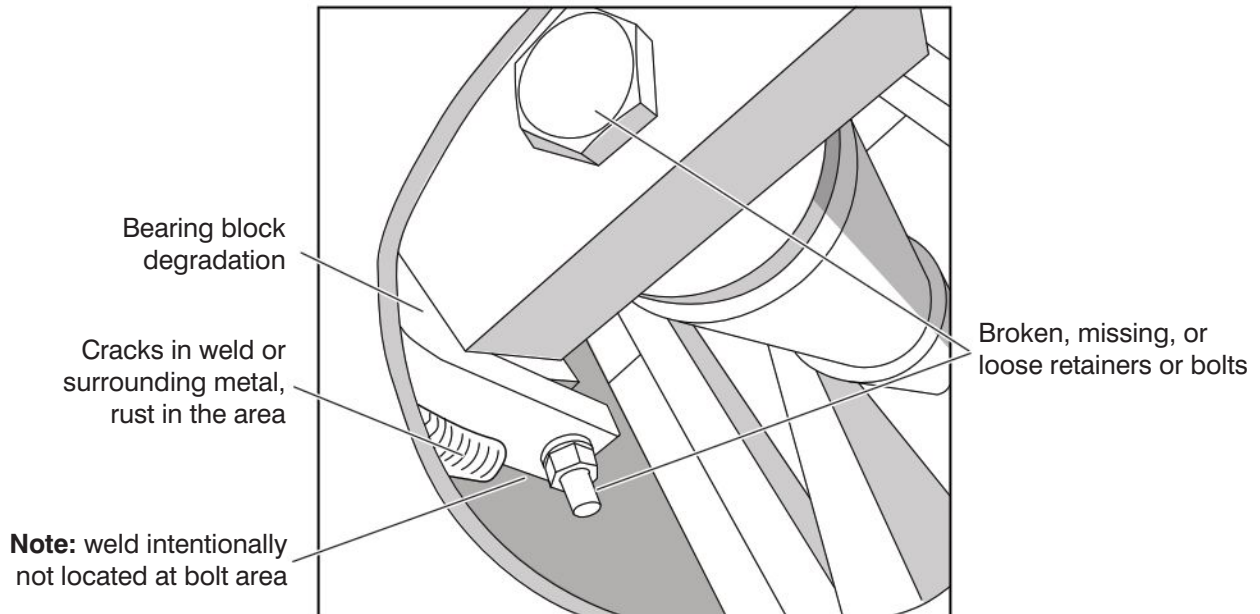

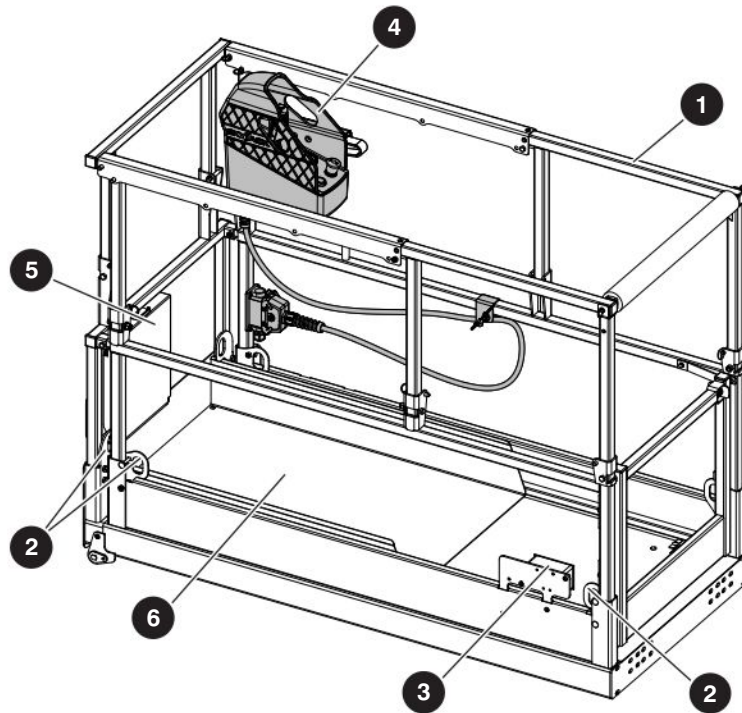

## 1.8 Platform inspection

### **⚠ WARNING**

**Fall Hazard. Use the three points of contact principle when you use the MEWP to enter or exit the platform. If you do not obey, there is a risk of death or serious injury.**

1. Enter the platform and close the gate.

#### **1 Railings and gate (B)**

- Make sure there are no loose or missing parts, and there is no visible damage.
- Make sure that the lock-pins and fasteners are correctly locked.
- Make sure that the **platform railings** are in the correct position and locked with lock-pins.
- Make sure that the **gate** is in good condition and operates correctly.
- Refer to [5.2-3 Railing Maintenance and Repair](#) for the railing maintenance information.

#### **2 Fall-protection anchorages (B)**

- Make sure that the fall-protection anchorages are correctly installed.
- Make sure there is no visible damage.

#### **3 AC power socket (B)**

- Make sure there is no visible damage.

#### **4 Platform control console (B)**

- Make sure that the control console is locked with lock-pins.
- Make sure that the platform control cable is correctly locked, and there is no visible damage.
- Make sure all the switches operate correctly.

#### **5 Manual storage box (B)**

- Make sure that the operation manual and other important documents are in the manual storage box.
- Make sure that the documents are in good condition, and you can read them.
- Always put the manuals and other documents back in the storage box after use.

#### **6 Extension platform (B)**

- Make sure that the extension platform is correctly installed.
- Make sure there is no visible damage or missing components.
- Make sure the lock-pins are correctly attached.

2. Use the MEWP ladder to exit the platform.

## 1.9 Function Tests

Do the function tests to find malfunctions in the MEWP before it is put into service. The operator must understand and follow the step-by-step instructions in the operation manual to do all the MEWP functions.

### **IMPORTANT**

**Do not operate a MEWP that does not function correctly. Lock and tag the MEWP, and remove it for servicing. Only a qualified service technician must repair the MEWP. If you do not obey, there is a risk of death or serious injury.**

- After repairs are completed, the operator must do a pre-operation inspection and a series of function tests again before putting MEWP into service.
- Before you do the function tests, read and understand the “Start Operation” section of the operation manual.
- Before you do the function tests, look for the operation manual with the same serial number as your MEWP. The operation manual has the instructions on which tests to do and how to do them correctly and successfully.



# Section 2 – Maintenance Tables and Diagrams

**Table 2.1 Standard Hose Numbering System**

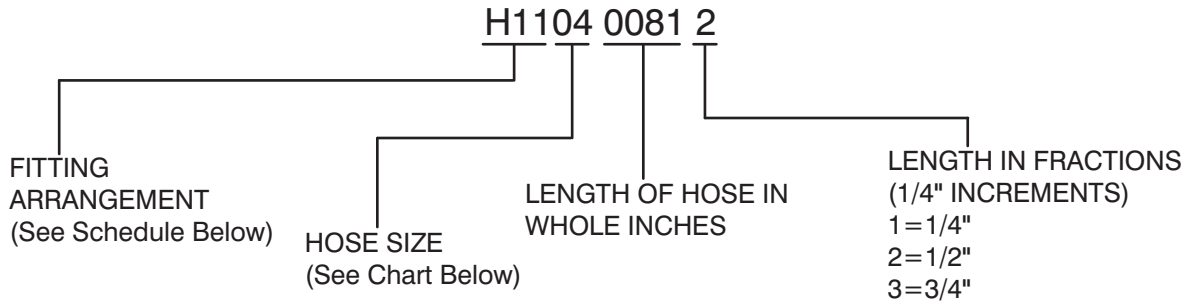

Using the number above as an example, H1104 0081 2, this hose requires a 37° JIC female swivel fitting on one end, and a medium length 90° JIC female swivel fitting for the other end. The hose must meet or exceed the S.A.E. 100R13 hose specification, and be a total of 81-1/2" long.



**NOTE**

Hose ends and hose must be from same manufacturer per S.A.E. J1273 Nov. '91, Sections 3.10 and 4.2. Hose ends and hose must be of the same size i.e. #4 size fittings must be used with #4 size hose.

Hose Size Chart														
Size	03	04	06	08	10	12	16	20	24	32	40	48	56	64
ID	3/16"	1/4"	3/8"	1/2"	5/8"	3/4"	1"	1-1/4"	1-1/2"	2"	2-1/2"	3"	3-1/2"	4"

Fitting Arrangement Schedule			
Hose Prefix	Hose End Fitting	Hose End Fitting	S.A.E. Hose Specification
H01	FEMALE, 37° JIC, SWIVEL	FEMALE, 37° JIC, SWIVEL	100R17
H02	FEMALE, 37° JIC, SWIVEL	FEMALE, 37° JIC, SWIVEL	100R13
H03	FEMALE, 37° JIC, SWIVEL	45°, FEMALE, 37° JIC, SWIVEL	100R17
H04	FEMALE, 37° JIC, SWIVEL	45°, FEMALE, 37° JIC, SWIVEL	100R13
H05	FEMALE, 37° JIC, SWIVEL	LONG 90°, FEMALE, 37° JIC, SWIVEL	100R17
H06	FEMALE, 37° JIC, SWIVEL	SHORT 90°, FEMALE, 37° JIC, SWIVEL	100R17
H07	LONG 90°, FEMALE, 37° JIC, SWIVEL	LONG 90°, FEMALE, 37° JIC, SWIVEL	100R17
H08	FEMALE, 37° JIC, SWIVEL	FEMALE, 37° JIC, SWIVEL	100R4
H09	FEMALE, 37° JIC, SWIVEL	45°, FEMALE, 37° JIC, SWIVEL	100R4
H10	FEMALE, 37° JIC, SWIVEL	MALE PIPE THREAD FITTING	100R17
H11	FEMALE, 37° JIC, SWIVEL	MEDIUM 90°, FEMALE, 37° JIC, SWIVEL	100R13
H12	SHORT 90°, FEMALE, 37° JIC, SWIVEL	SHORT 90°, FEMALE, 37° JIC, SWIVEL	100R17
H13	FEMALE, 37° JIC, SWIVEL	REUSABLE MALE PIPE THREAD FITTING	300 PSI
H14	REUSABLE MALE PIPE THREAD FITTING	NO FITTING	300 PSI

Hose Prefix	Hose End Fitting	Hose End Fitting	S.A.E. Hose Specification
H15	REUSABLE FEMALE, 37° JIC, SWIVEL	REUSABLE FEMALE, 37° JIC, SWIVEL	300 PSI
H16	NO FITTING	NO FITTING	100R4
H17	NO FITTING	NO FITTING	300 PSI
H18	REUSABLE, FEMALE, 37° JIC, SWIVEL	NO FITTING	300 PSI
H19	LONG 90°, FEMALE, 37° JIC, SWIVEL	FEMALE, 37° JIC, SWIVEL	100R13
H20	FEMALE, SHORT 37° JIC, SWIVEL	SHORT 90°, FEMALE, 37° JIC, SWIVEL	100R4
H21	FEMALE, SHORT 37° JIC, SWIVEL	SHORT 90°, FEMALE, 37° JIC, SWIVEL	100R2AT
H22	FEMALE, 37° JIC, SWIVEL	FEMALE, 37° JIC, SWIVEL	100R2AT
H23	FEMALE, LONG 37° JIC, SWIVEL	LONG 90°, FEMALE, 37° JIC, SWIVEL	100R2AT
H24	FEMALE, SHORT 37° JIC, SWIVEL	SHORT 90°, FEMALE, 37° JIC, SWIVEL	100R13
H25	FEMALE, 37° JIC, SWIVEL	FEMALE, 37° JIC, SWIVEL	100R4
H30	MEDIUM 90°, FEMALE, 37° JIC, SWIVEL	FEMALE, 37° JIC, SWIVEL	100R17
H31	FEMALE, 37° JIC, SWIVEL	FEMALE, 37° JIC, SWIVEL	100R17
H32	SHORT 45°, FEMALE, 37° JIC, SWIVEL	FEMALE, 37° JIC, SWIVEL	100R17
H33	MEDIUM 45°, FEMALE, 37° JIC, SWIVEL	FEMALE, 37° JIC, SWIVEL	100R17
H34	SHORT 90°, FEMALE, 37° JIC, SWIVEL	FEMALE, 37° JIC, SWIVEL	100R17
H35	MEDIUM 90°, FEMALE, 37° JIC, SWIVEL	FEMALE, 37° JIC, SWIVEL	100R17
H36	LONG 90°, FEMALE, 37° JIC, SWIVEL	FEMALE, 37° JIC, SWIVEL	100R17
H37	SHORT 45°, FEMALE, 37° JIC, SWIVEL	FEMALE, 37° JIC, SWIVEL	100R4
H38	SHORT 90°, FEMALE, 37° JIC, SWIVEL	FEMALE, 37° JIC, SWIVEL	100R4
H39	LONG 90°, FEMALE, 37° JIC, SWIVEL	FEMALE, 37° JIC, SWIVEL	100R4
H40	SHORT 90°, FEMALE, 37° JIC, SWIVEL	FEMALE, 37° JIC, SWIVEL	100R16
H43	FEMALE, 37° JIC, SWIVEL	FEMALE, 37° JIC, SWIVEL	100R16
H51	FEMALE, 37° JIC, SWIVEL	FEMALE, 37° JIC, SWIVEL	100R17
H52	SHORT 45°, FEMALE, 37° JIC, SWIVEL	FEMALE, 37° JIC, SWIVEL	100R17
H53	MEDIUM 45°, FEMALE, 37° JIC, SWIVEL	FEMALE, 37° JIC, SWIVEL	100R17
H54	SHORT 90°, FEMALE, 37° JIC, SWIVEL	FEMALE, 37° JIC, SWIVEL	100R17
H55	MEDIUM 90°, FEMALE, 37° JIC, SWIVEL	FEMALE, 37° JIC, SWIVEL	100R17
H56	LONG 90°, FEMALE, 37° JIC, SWIVEL	FEMALE, 37° JIC, SWIVEL	100R17
H57	SHORT 45°, FEMALE, SAE ORFS, SWIVEL	FEMALE, SAE ORFS, SWIVEL	100R13
H58	FEMALE, SAE ORFS, SWIVEL	FEMALE, SAE ORFS, SWIVEL	100R13
H59	MEDIUM 90°, FEMALE, SAE ORFS, SWIVEL	FEMALE, SAE ORFS, SWIVEL	100R13
H60	FEMALE, 37° JIC, SWIVEL	FEMALE, 37° JIC, SWIVEL	100R17
H61	FEMALE, 37° JIC, SWIVEL	FEMALE, 37° JIC, SWIVEL	100R16
H62	SHORT 90°, FEMALE, 37° JIC, SWIVEL	FEMALE, 37° JIC, SWIVEL	100R16
H63	MEDIUM 90°, FEMALE, 37° JIC, SWIVEL	FEMALE, 37° JIC, SWIVEL	100R16
H64	LONG 90°, FEMALE, 37° JIC, SWIVEL	FEMALE, 37° JIC, SWIVEL	100R16
H65	MEDIUM 67°, FEMALE, 37° JIC, SWIVEL	FEMALE, 37° JIC, SWIVEL	100R12
H66	FEMALE, 37° JIC, SWIVEL	NO FITTING	100R4
H67	FEMALE, 37° JIC, SWIVEL	FEMALE, 37° JIC, SWIVEL	100R19
H68	SHORT 45°, FEMALE, 37° JIC, SWIVEL	FEMALE, 37° JIC, SWIVEL	100R19
H69	MEDIUM 90°, FEMALE, 37° JIC, SWIVEL	FEMALE, 37° JIC, SWIVEL	100R19
H70	LONG 90°, FEMALE, 37° JIC, SWIVEL	FEMALE, 37° JIC, SWIVEL	100R19
H71	LONG 90°, FEMALE, SAE ORFS, SWIVEL	FEMALE, SAE ORFS, SWIVEL	100R15

**Table 2.2 Torque Specifications for Fasteners (US)**

Size	Torque Type	SAE2		SAE 5		SAE 8	
		Dry	Lubed	Dry	Lubed	Dry	Lubed
4-40	(in-lb)	(5)	(4)	(8)	(6)	(12)	(9)
	Nm	0.6	0.5	0.9	0.7	1.4	1.0
4-48	(in-lb)	(6)	(5)	(9)	(7)	(13)	(10)
	Nm	0.7	0.6	1.0	0.8	1.5	1.1
6-32	(in-lb)	(10)	(8)	(16)	(12)	(23)	(17)
	Nm	1.1	0.9	1.8	1.4	2.6	1.9
6-40	(in-lb)	(12)	(9)	(18)	(13)	(25)	(19)
	Nm	1.4	1.0	2.0	1.5	2.8	2.1
8-32	(in-lb)	(19)	(14)	(30)	(22)	(41)	(31)
	Nm	2.1	1.6	3.4	2.5	4.6	3.5
8-36	(in-lb)	(20)	(15)	(31)	(23)	(43)	(32)
	Nm	2.3	1.7	3.5	2.6	4.9	3.6
10-24	(in-lb)	(27)	(21)	(43)	(32)	(60)	(45)
	Nm	3.1	2.4	4.9	3.6	6.8	5.1
10-32	(in-lb)	(31)	(23)	(49)	(36)	(68)	(51)
	Nm	3.5	2.6	5.5	4.1	7.7	5.8
1/4-20	(in-lb) ft-lb	(66)	(50)	8	(75)	12	9
	Nm	7.5	5.6	11	8.5	16	12
1/4-28	(in-lb) ft-lb	(76)	(56)	10	(86)	14	10
	Nm	8.6	6.3	14	9.7	19	14
5/16-18	ft-lb	11	8	17	13	25	18
	Nm	15	11	23	18	34	24
5/16-24	ft-lb	12	9	19	14	25	20
	Nm	16	12	26	19	34	27
3/8-16	ft-lb	20	15	30	23	45	35
	Nm	27	20	41	31	61	47
3/8-24	ft-lb	23	17	35	25	50	35
	Nm	31	23	47	34	68	47
7/16-14	ft-lb	32	24	50	35	70	55
	Nm	43	33	68	47	95	75
7/16-20	ft-lb	36	27	55	40	80	60
	Nm	49	37	75	54	108	81
1/2-13	ft-lb	50	35	75	55	110	80
	Nm	68	47	102	75	149	108
1/2-20	ft-lb	55	40	90	65	120	90
	Nm	75	54	122	88	163	122

Size	Torque Type	SAE2		SAE 5		SAE 8	
		Dry	Lubed	Dry	Lubed	Dry	Lubed
9/16-12	ft-lb	70	55	110	80	150	110
	Nm	95	75	149	108	203	149
9/16-18	ft-lb	80	60	120	90	170	130
	Nm	108	81	163	122	230	176
5/8-11	ft-lb	100	75	150	110	220	170
	Nm	136	102	203	149	298	230
5/8-18	ft-lb	110	85	180	130	240	180
	Nm	149	115	244	176	325	244
3/4-10	ft-lb	175	130	260	200	380	280
	Nm	237	176	353	271	515	380
3/4-16	ft-lb	200	150	300	220	420	320
	Nm	271	203	407	298	569	434
7/8-9	ft-lb	170	125	430	320	600	460
	Nm	230	169	583	434	813	624
7/8-14	ft-lb	180	140	470	360	660	500
	Nm	244	190	637	488	895	678
1-8	ft-lb	250	190	640	480	900	680
	Nm	339	258	868	651	1220	922
1-12	ft-lb	270	210	710	530	1000	740
	Nm	366	285	963	719	1356	1003
1-14	ft-lb	280	210	730	540	1020	760
	Nm	380	285	990	732	1383	1030
1 1/8-7	ft-lb	350	270	800	600	1280	960
	Nm	475	366	1085	813	1735	1302
1 1/8-12	ft-lb	400	300	880	660	1440	1080
	Nm	542	407	1193	895	1952	1464
1 1/4-7	ft-lb	500	380	1120	840	1820	1360
	Nm	678	515	1519	1139	2468	1844
1 1/4-12	ft-lb	550	420	1240	920	2000	1500
	Nm	746	569	1681	1247	2712	2034
1 3/8-6	ft-lb	670	490	1460	1100	2380	1780
	Nm	908	664	1979	1491	3227	2413
1 3/8-12	ft-lb	750	560	1680	1260	2720	2040
	Nm	1017	759	2278	1708	3688	2766
1 1/2-6	ft-lb	870	650	1940	1460	3160	2360
	Nm	1180	881	2630	1979	4284	3200
1 1/2-12	ft-lb	980	730	2200	1640	3560	2660
	Nm	1329	990	2983	2224	4827	3606

**NOTE:** Lubed includes lubricants such as lubrizing, oil, grease, or uncured Loctite.

1374AA



**Table 2.3 Torque Specifications for Fasteners (Metric)**

Size	Torque Type	8.8		10.9	
		Dry	Lubed	Dry	Lubed
M5 x 0.80	(in-lb)	(54)	(41)	(78)	(59)
	Nm	6.1	4.6	8.8	6.7
M6 x 1.00	(in-lb)	(92)	(69)	(133)	(99)
	Nm	10.4	7.8	15	11.2
M7 x 1.00	(in-lb)	(156)	(116)	(222)	(167)
	Nm	17.6	13.1	25.1	18.9
M8 x 1.25	(in-lb)	(225)	(169)	(333)	(242)
	Nm	25.4	19.1	37.6	27.3
M10 x 1.50	ft-lb	37	28	53	40
	Nm	50	38	72	54
M12 x 1.75	ft-lb	65	49	93	69
	Nm	88	66	126	94
M14 x 2.00	ft-lb	104	78	148	111
	Nm	141	106	201	150
M16 x 2.00	ft-lb	161	121	230	172
	Nm	218	164	312	233
M18 x 2.50	ft-lb	222	167	318	238
	Nm	301	226	431	323
M20 x 2.50	ft-lb	314	235	449	337
	Nm	426	319	609	457
M22 x 2.50	ft-lb	428	321	613	460
	Nm	580	435	831	624
M24 x 3.00	ft-lb	543	407	776	582
	Nm	736	552	1052	789
M27 x 3.00	ft-lb	796	597	1139	854
	Nm	1079	809	1544	1158
M30 x 3.50	ft-lb	1079	809	1543	1158
	Nm	1463	1097	2092	1570
M33 x 3.50	ft-lb	1468	1101	2101	1576
	Nm	1990	1493	2849	2137
M36 x 4.00	ft-lb	1886	1415	2699	2024
	Nm	2557	1918	3659	2744

**NOTE:** Lubed includes lubricants such as lubrizing, oil, grease, or uncured Loctite.

1375AB



**Table 2.4 Torque Specifications for Hydraulic Couplings & Hoses**

<b>Hydraulic Coupling Torque Chart O-Ring Port Connectors</b>				
<b>SAE Size</b>	<b>Steel Ports</b>		<b>Non-ferrous Ports</b>	
	<b>ft-lb</b>	<b>Nm</b>	<b>ft-lb</b>	<b>Nm</b>
4	14-16	20-22	9-10	12-13
6	24-26	33-35	15-16	20-21
8	50-60	68-78	30-36	41-47
10	72-80	98-110	43-48	60-66
12	125-135	170-183	75-81	102-110
16	200-220	270-300	120-132	162-180
20	210-280	285-380	126-168	171-228
24	270-360	370-490	162-216	222-294
32	-	-	-	-

<b>Hose End Torque Chart for JIC</b>									
<b>Size</b>		<b>Steel</b>				<b>Brass</b>			
<b>Dash</b>	<b>Frac.</b>	<b>ft-lb</b>		<b>Nm</b>		<b>ft-lb</b>		<b>Nm</b>	
		<b>Min.</b>	<b>Max.</b>	<b>Min.</b>	<b>Max.</b>	<b>Min.</b>	<b>Max.</b>	<b>Min.</b>	<b>Max.</b>
-4	1/4"	10	11	13	15	5	6	6.75	9
-6	3/8"	17	19	23	26	12	15	17	20
-8	1/2"	34	38	47	52	20	24	27.66	33
-10	5/8"	50	56	69	76	34	40	46.33	55
-12	3/4"	70	78	96	106	53	60	72.33	82
-16	1"	94	104	127	141	74	82	100.5	111
-20	1 1/4"	124	138	169	188	75	83	101.5	113
-24	1 1/2"	156	173	212	235	79	87	107	118
-32	2"	219	243	296	329	158	175	214	237

<b>Hose End Torque Chart for Flat-Face O-Ring Seal (Steel)</b>					
<b>Size</b>		<b>Torque Specification</b>			
<b>Dash</b>	<b>Frac.</b>	<b>ft-lb</b>		<b>Nm</b>	
		<b>Min.</b>	<b>Max.</b>	<b>Min.</b>	<b>Max.</b>
-4	1/4"	10	12	14	16
-6	3/8"	18	20	24	27
-8	1/2"	32	40	43	54
-10	5/8"	46	56	60	75
-12	3/4"	65	80	90	110
-14	1"	65	80	90	110
-16	1 1/4"	92	105	125	240
-20	1 1/2"	125	140	170	190
-24	2"	150	180	200	245

1276AA

**Table 2.5 Specifications & Features - ANSI/CSA**

<b>Models</b>	<b>3215</b>	<b>3219</b>
Weight*	1148 kg 2531 lb	1476 kg 3255 lb
Overall width	0.82 m 32.28 in	
Overall length (Platform Retracted)	1.80 m 70.87 in	
Overall length - RapidFold™ (Platform Retracted)	N/A	1.81 m 71.26 in
Platform Size Inside (Platform Extended)	0.65 m x 1.54 m 25.59 in x 60.63 in	
<b>Height</b>		
Working Height	6.27 m 21 ft 2 in	7.48 m 24 ft 6 in
Platform Elevated Height	4.44 m 14 ft 7 in	5.65 m 18 ft 6 in
Stowed Height (Railings Down)	1.67 m 65.75 in	1.79 m 70.47 in
Stowed Height - RapidFold™ (Railings Down)	N/A	2.02 m 79.70 in
Stowed Height (Railings Up)	2.03 m 79.92 in	2.14 m 84.25 in
Drive Height	FULL	
<b>Standard Operating Times</b>		
Lift Time (No Load)	15 s	15 s
Lower Time (No Load)	22 s	32 s
Lift Time (Rated Load)	17 s	17 s
Lower Time (Rated Load)	16 s	24 s
<b>Chassis</b>		
Normal Drive Speed	3.38 km/h 2.1 mph	
Elevated Drive Speed	1.13 km/h 0.7 mph	
Gradeability (Ramp Angle)	25%	
Tires (Solid Rubber)	12 x 4 x 8	
<b>Hydraulic Oil</b>		
Type	ATF Dexron III	
	SHELL NATURELLE HF-E 32	
Tank Capacity (Liters)	11.3 L (3 gal)	
<b>Sound Pressure Level at Platform Level</b>		
Does not exceed:	70 db(A)	

\* Weight with standard 0.9 m extension platform. Refer to serial nameplate for specific applications. 2002AB

**Table 2.6 Specifications & Features - CE**

<b>Models</b>	<b>3215</b>	<b>3219</b>
Weight*	1148 kg	1476 kg
Overall width	0.82 m	
Overall Length (Platform Retracted)	1.80 m	
Overall Length (Platform Extended)	2.64 m	
Platform Size, Inside (Platform Retracted)	1.54 m	
Platform Size Inside (Platform Extended)	2.39 m	
<b>Height</b>		
Working Height	6.44 m	7.65 m
Platform Elevated Height	4.44 m	5.65 m
Stowed Height (Railings Down)	1.67 m	1.79 m
Stowed Height (Railings Up)	2.03 m	2.14 m
Drive Height	FULL	
<b>Standard Operating Times</b>		
Lift Time (No Load)	16 s	16 s
Lower Time (No Load)	25 s	33 s
Lift Time (Rated Load)	17 s	17 s
Lower Time (Rated Load)	18 s	25 s
<b>Chassis</b>		
Normal Drive Speed	3.38 km/h	
Elevated Drive Speed	1.13 km/h	
Gradeability (Ramp Angle)	25%	
Tires (Solid Rubber)	12 x 4 x 8	
<b>Hydraulic Oil</b>		
Type	ATF DEXRON III	
	SHELL NATURELLE HF-E 32	
Tank Capacity (Liters)	11.3 L	
<b>Sound Pressure Level at Platform Level</b>		
Does not exceed:	70 db(A)	

\* Weight with standard 0.9 m extension platform. Refer to serial nameplate for specific applications. 2003AA

**Table 2.7 Specifications & Features - AS**

<b>Models</b>	<b>3215</b>	<b>3219</b>
Weight*	1148 kg	1476 kg
Overall Width	0.82 m	
Overall Length (Platform Retracted)	1.80 m	
Overall Length (Platform Extended)	2.64 m	
Platform Size, Inside (Platform Retracted)	1.54 m	
Platform Size Inside (Platform Extended)	2.39 m	
<b>Height</b>		
Working Height	6.44 m	7.65 m
Platform Elevated Height	4.44 m	5.65 m
Stowed Height (Railings Down)	N/A	N/A
Stowed Height (Railings Up)	1.88 m	1.99 m
Drive Height	FULL	
<b>Standard Operating Times</b>		
Lift Time (No Load)	15 s	15 s
Lower Time (No Load)	22 s	32 s
Lift Time (Rated Load)	17 s	17 s
Lower Time (Rated Load)	16 s	24 s
<b>Chassis</b>		
Normal Drive Speed	3.38 km/h	3.03 km/h
Elevated Drive Speed	1.13 km/h	
Gradeability (Ramp Angle)	25%	
Tires (Solid Rubber)	12 x 4 x 8	
<b>Hydraulic Oil</b>		
Type	ATF DEXRON III	
	SHELL NATURELLE HF-E 32	
Tank Capacity (Liters)	11.3 L	
<b>Sound Pressure Level at Platform Level</b>		
Does not exceed:	70 db(A)	

\* Weight with standard 0.9 m extension platform. Refer to serial nameplate for specific applications.

2004AA

**Table 2.8 Specifications & Features - KC**

<b>Models</b>	<b>3215</b>	<b>3219</b>
Weight*	1148 kg	1476 kg
Overall Width	0.82 m	
Overall Length (Platform Retracted)	1.80 m	
Overall Length (Platform Extended)	2.64 m	
Platform Size, Inside (Platform Retracted)	1.55 m	
Platform Size Inside (Platform Extended)	2.39 m	
<b>Height</b>		
Working Height	6.44 m	7.65 m
Platform Elevated Height	4.44 m	5.65 m
Stowed Height (Railings Down)	N/A	N/A
Stowed Height (Railings Up)	1.92	2.03
Drive Height	FULL	
<b>Standard Operating Times</b>		
Lift Time (No Load)	15 s	15 s
Lower Time (No Load)	22 s	32 s
Lift Time (Rated Load)	17 s	17 s
Lower Time (Rated Load)	16 s	24 s
<b>Chassis</b>		
Normal Drive Speed	3.38 km/h	
Elevated Drive Speed	1.13 km/h	
Gradeability (Ramp Angle)	25%	
Tires (Solid Rubber)	12 x 4 x 8	
<b>Hydraulic Oil</b>		
Type	ATF DEXRON III	
	SHELL NATURELLE HF-E 32	
Tank Capacity (Liters)	11.3 L	
<b>Sound Pressure Level at Platform Level</b>		
Does not exceed:	70 db(A)	

\* Weight with standard 0.9 m extension platform. Refer to serial nameplate for specific applications. 2005AA

**Table 2.9 Maximum Platform Capacities (Evenly Distributed)**

Model	Wind Rating	Total Platform Capacity		Extension Platform Capacity		Manual Force	Tilt Cutout Setting
3215 ANSI/CSA	0 m/s [0 mph]	272 kg [600 lb]	2 Persons	113 kg [250 lb]	1 Person	400 N 90 lbf	1.5° × 3.5°
	12.5 m/s [28 mph]		1 Person			200 N 45 lbf	
3219 ANSI/CSA	0 m/s [0 mph]	227 kg [500 lb]	2 Persons	113 kg [250 lb]	1 Person	400 N 90 lbf	1.5° × 3.5°
	12.5 m/s [28 mph]		1 Person			200 N 45 lbf	
3215 CE	0 m/s	272 kg	2 Persons	113 kg	1 Person	400 N	1.5° × 3.5°
	12.5 m/s		1 Person			200 N	
3219 CE	0 m/s	227 kg	2 Persons	113 kg	1 Person	400 N	1.5° × 3.5°
	12.5 m/s		1 Person			200 N	
3215 AS	0 m/s	272 kg	2 Persons	113 kg	1 Person	400 N	1.5° × 3.5°
	12.5 m/s		1 Person			200 N	
3219 AS	0 m/s	227 kg	2 Persons	113 kg	1 Person	400 N	1.5° × 3.5°
	12.5 m/s		1 Person			200 N	
3215 KC	0 m/s	272 kg	2 Persons	113 kg	1 Person	400 N	1.5° × 3.5°
	12.5 m/s		1 Person			200 N	
3219 KC	0 m/s	227 kg	2 Persons	113 kg	1 Person	400 N	1.5° × 3.5°
	12.5 m/s		1 Person			200 N	

2006AA

**Table 2.10 Floor Loading Pressure**

Model		Weights				Pressures			
		MEWP weight		Max weight per wheel		LCP**		OFL**	
		kg	lb	kg	lb	kPa	psi	kPa	psf
3215 ANSI/CSA	min*	1148	2531	290	640	670	127.5	7.9	164
	max*	1420	3131	500	1080	1006	165.4	9.7	202
3219 ANSI/CSA	min*	1476	3255	370	816	907	130.4	10.1	210.9
	max*	1703	3755	608	1340	1150	163.5	11.7	244.4
3215 CE	min*	1148	-	290	-	670	-	7.9	-
	max*	1420	-	500	-	1006	-	9.7	-
3219 CE	min*	1476	-	370	-	907	-	10.1	-
	max*	1703	-	608	-	1150	-	11.7	-
3215 AS	min*	1148	-	290	-	670	-	7.9	-
	max*	1420	-	500	-	1006	-	9.7	-
3219 AS	min*	1476	-	370	-	907	-	10.1	-
	max*	1703	-	608	-	1150	-	11.7	-
3215 KC	min*	1148	-	290	-	670	-	7.9	-
	max*	1420	-	500	-	1006	-	9.7	-
3219 KC	min*	1476	-	370	-	907	-	10.1	-
	max*	1703	-	608	-	1150	-	11.7	-

\* **Min:** Minimum MEWP weight (Unloaded platform, no options/attachments) **2007A**  
**Max:** Maximum MEWP weight (Platform loaded to capacity with options/attachments)

**Wheel** is the weight that can be experienced on one wheel.

**Note:** This is more than 25% of the machine weight due to possible weight distribution over the machine and platform.

\*\* **LCP:** Local Concentrated Pressure is a measure of how hard the MEWP presses on the area in direct contact with the floor/tire.  
**OFL:** Overall Floor Load (Pressure) is a measure of the average load the MEWP imparts on the whole surface directly underneath the chassis. This has been calculated by dividing the MEWP weight by the overall floor area occupied by the MEWP (on wheels).

**Note:** The floor covering (e.g., tile, carpet, etc.) or the structure (e.g., beams) of the operating surface must be able to withstand more than the values indicated above.

**Note:** The LCP or OFL that an individual surface can withstand varies from structure to structure and is generally determined by the engineer or architect for that particular structure.

**Table 2.11 Torque Specifications**

Base	Torque (lb-ft)						Torque (Nm)	
Directional Valve Mounting Bolts	2.3-2.7 lb-ft (28-32 lb-in)						3.2 -3 .6 Nm	
Front Wheel Castle Nut	150* lb-ft						203* Nm	
Hydraulic Motor Mounting Bolts	85 lb-ft						115 Nm	
Rear Wheel Castle Nut - Pin Brakes	Finger tighten until snug*							
Rear Wheel Castle Nut - Wet Brakes	150* lb-ft						203* Nm	
Wheel Brake Mounting Bolts	85 lb-ft						115 Nm	
*See section 5 for the full torque procedure.								
Cartridge							Coils	
Valve Size	8	38	58	10	12	16	All coil sizes	
Torque (lb-ft) max	20	20	20	25	35	50	4 to 5	
Torque (lb-in) max	240	240	240	300	420	600	48 to 60	
Torque (Nm) max	27.12	27.12	27.12	33.9	47.46	67.8	5.42 to 6.78	
SAE Plugs								
Port Size	2	4	5	6	8	10	12	16
Torque (lb-ft) max	3	10	15	15	25	25	30	35
Torque (lb-in) max	36	120	180	180	300	300	360	420
Torque (Nm) max	4.07	13.56	20.34	20.34	33.9	33.9	40.68	47.46









































Newton-meter = Nm      Pound-foot = lb-ft      Pound-inch = lb-in      2008AB  
 Additional Torque Specifications may be found in Section 5.





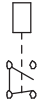
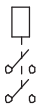
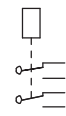

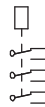























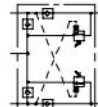







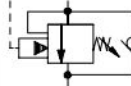

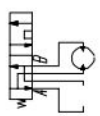

---

# Section 3 – System Component Identification and Schematics

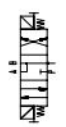
**Table 3.1 Electrical Symbol Chart**

 CIRCUITS CROSSING NO CONNECTION	 HOURMETER	 KEY SWITCH	 LIMIT SWITCH N.O.
 CIRCUITS CONNECTED	 LIGHT	 FOOT SWITCH	 LIMIT SWITCH N.O. HELD CLOSED
 BATTERY	 HYDRAULIC VALVE COIL	 TOGGLE SWITCH	 LIMIT SWITCH N.C.
 GROUND	 PROPORTIONAL HYDRAULIC VALVE COIL	 PUSH BUTTON	 LIMIT SWITCH N.C. HELD OPEN
 FUSE	 ELECTRIC MOTOR	 ROTARY SWITCH	 SILICON CONTROLLED RECTIFIER
 CIRCUIT BREAKER	 HORN	 LIMIT SWITCH	 PROXIMITY SWITCH
 VOLT METER	 EMERGENCY STOP BUTTON	 CAM OPERATED LIMIT SWITCH	 PNP TRANSISTOR
 CAPACITOR	 RESISTOR	 TILT SWITCH	 NPN TRANSISTOR
 POTENTIOMETER	 LEVEL SENSOR	 SINGLE POLE SINGLE THROW RELAY	 PRESSURE/ VACUUM SWITCH
 SINGLE POLE DOUBLE THROW RELAY	 DOUBLE POLE SINGLE THROW RELAY	 DOUBLE POLE DOUBLE THROW RELAY	 TEMPERATURE SWITCH
 TRIPLE POLE DOUBLE THROW RELAY	 DIODE	 RHEOSTAT	

**Table 3.2 Hydraulic Symbol Chart**

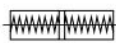
	LINE CROSSING		VARIABLE DISPLACEMENT PUMP		SHUTTLE VALVE		VELOCITY FUSE
	LINE JOINED		HAND PUMP		ACCUMULATOR, GAS CHARGED		SINGLE ACTING CYLINDER
	HYDRAULIC TANK		RELIEF VALVE		CUSHION CYLINDER		DOUBLE ACTING CYLINDER
	HYDRAULIC FILTER WITH BYPASS		PRESSURE REDUCING VALVE		PRESSURE SWITCH		DOUBLE ACTING DOUBLE RODDED CYLINDER
	ELECTRIC MOTOR		FIXED ORIFICE		MOTION CONTROL VALVE		SPRING APPLIED HYDRAULIC RELEASED BRAKE
	ENGINE		ADJUSTABLE FLOW CONTROL		FLOW DIVIDER COMBINER		BRAKE CYLINDER
	FIXED DISPLACEMENT PUMP		CHECK VALVE		COUNTER BALANCE VALVE		ROTARY ACTUATOR
	VARIABLE DISPLACEMENT HYDRAULIC MOTOR		OIL COOLER		VALVE COIL		BI DIRECTIONAL HYDRAULIC MOTOR
	SERIES PARALLEL HYDRAULIC MOTOR		TWO POSITION TWO WAY NORMALLY CLOSED VALVE		TWO POSITION THREE WAY VALVE		THREE POSITION FOUR WAY CLOSED CENTER OPEN PORT
	TWO POSITION TWO WAY NORMALLY OPEN VALVE		TWO POSITION THREE WAY VALVE		THREE POSITION FOUR WAY CLOSED CENTER CLOSED PORT		
	PRESSURE TRANSDUCER		MAIN LINES Solid		PILOT LINES Dashed		
	SERVO						

### 3.3 Wire Number and Color Code

WIRE NO.	WIRE COLOR	WIRE NO.	WIRE COLOR	WIRE NO.	WIRE COLOR	WIRE NO.	WIRE COLOR	WIRE NO.	WIRE COLOR
00	WHT	21	GRN/BLK	42	PNK/BLU	84	YEL/BRN	1002	RED/BLK
000	WHT	21	WHT/RED	43	PNK/RED	85	ORG/BLK/WHT	1003	ORG
B1	BLU/PINK	22	ORG/BLU	44	PNK/ORG	87	BRN/ORG	1006	BLU
01	PUR/BLK	23	BLK/WHT/RED	49	GRN	88	BRN/PNK	1008	GRY
02	WHT	23	BLK/WHT	50	BRN/WHT	89	BRN/GRN	1100	BLK
03	GRN/PUR	24	BLU/BLK	55	GRY/RED	99	PUR/RED	1103	ORG
04	RED/YEL	25	ORG/GRN	56	WHT/ORG	100	RED	2001	BRN
05	PUR/BLACK	26	GRN	57	BLK/WHT	101		2002	RED
06		27	BLK	59	ORG/BLK	102	PNK	2005	GRN/WHT
07	RED	28	GRN/RED	60	BLK/RED/GRN	103	RED	3008	GRY
08	PUR/WHT	29	BLU/YEL	71	BLU/RED	103B	BLK	4002	RED
09	ORG/RED	30	BRN	72	WHT/BLK/RED	103C	WHT	7002	RED
10	BLU/WHT	31	RED/WHT	73	WHT/RED/GRN	104	RED		
11	YEL/BLK	32	GRN/BLK	74	BLK/RED/GRN	105	GRN		
12	BRN/RED	33		75	WHT/RED/GRN	106	BLU		
13	ORG	34	GRN/WHITE	76	RED/GRN	200	BLK/WHT		
14	BLK	35	RED/BRN	77	GRN/BLK/WHT	203	ORG/BLK		
15	BLU	36	YEL	78	RED/BLK/WHT	205	GRN		
16	WHT/BLK	37	GRN/WHT	79	YEL/PNK	209	WHT/BLK		
17	BLU/RED	38		80	YEL/PUR	900	WHT		
18	RED/BLK	39	GRN/WHT	81	YEL/RED	902	WHT		
19	ORG/BLK	40	PNK/YEL	82	YEL/BLU	910	BLK		
20	BLK/WHT/RED	41	PNK	83	YEL/ORG	1001	BRN/WHT		

This table is to be used as a wire number/color reference for electrical drawings and schematics.

All wire numbers will retain their original color coding, for example if wire 7 is red, wire 7A, 7B, and 7C will also be red.

### 3.4 Hydraulic Parts List

Index No.	Skyjack Part No.	Description
2H-13	103655	VALVE, Lower <b>(SJ3219)</b>
2H-13C	207870	VALVE, Lower <b>(SJ3215)</b>
3H-14	106273	VALVE, Lift
3H-17	103623	VALVE, Brake
4H-15	153334	VALVE, Reverse
4H-16	153334	VALVE, Forward
4H-23A	153334	VALVE, Steer Right
4H-24A	153334	VALVE, Steer Left
BR1	217960	BRAKE, Hydraulic <b>(CE, AS &amp; KC)</b>
BR2	217960	BRAKE, Hydraulic <b>(CE, AS &amp; KC)</b>
C1	226482	CYLINDER, Lift
C2	151733	CYLINDER, Steering
C3	204005	CYLINDER, Brake <b>(ANSI/CSA)</b>
CB1	147888	COUNTERBALANCE, Motors
F1	109568	FILTER, Return
M1	161094	MOTOR, Left <b>(ANSI/CSA, CE &amp; KC)</b>
	194615	MOTOR, Left <b>(AS)</b>
M2	161094	MOTOR, Right <b>(ANSI/CSA, CE &amp; KC)</b>
	194615	MOTOR, Right <b>(AS)</b>
MB1	226496	MANIFOLD, Main <b>(SJ3215 ANSI/CSA)</b>
	226497	MANIFOLD, Main <b>(SJ3215 CE, AS &amp; KC)</b>
	226479	MANIFOLD, Main <b>(SJ3219 ANSI/CSA)</b>
	226481	MANIFOLD, Main <b>(SJ3219 CE, AS &amp; KC)</b>
MB2	138021	MANIFOLD, Free-Wheel
MB3	212912	MANIFOLD, Holding
MB4	209218	MANIFOLD, Brake Release <b>(CE, AS &amp; KC)</b>
01	310056	ORIFICE, Steer - 0.040" <b>(SJ3215)</b>
02	310056	ORIFICE, Steer - 0.040" <b>(SJ3215)</b>
03	226498	ORIFICE, 0.094" <b>(SJ3215)</b>
	226477	ORIFICE, 0.059" <b>(SJ3219)</b>
04	147656	ORIFICE, 0.024"
05	130407	ORIFICE, 0.051" <b>(ANSI/CSA)</b>
P1	161936	PUMP, DC Motor
	165610	PUMP, DC Motor <b>(ANSI/CSA EE-Rated)</b>
P2	146559	PUMP, DC Motor <b>(CE, AS &amp; KC)</b>
QD1	122420	QUICK DISCONNECT
R1	104534	RELIEF, System
R2	104534	RELIEF, Lift
SN1	210292	SNUBBER, 5um
V1	103136	VALVE, Free-Wheel
V2	146561	VALVE, Brake Override <b>(CE, AS &amp; KC)</b>

## 3.5 Electrical Parts List

Index No.	Skyjack Part No.	Description
2H-13	104410	COIL, 12 Volt - Holding Valve
3H-14	105610	COIL, 24 Volt - Lift
4H-15	153334	COIL, 24 Volt - Reverse
4H-16	153334	COIL, 24 Volt - Forward
3H-17	103605	COIL, 24 Volt - Brake
4H-23A	153334	COIL, 24 Volt - Right Steer
4H-24A	153334	COIL, 24 Volt - Left Steer
AT1	220597	TRANSDUCER, Angle
B1-4	103480	BATTERY, 6V - US 2200
	106552	BATTERY, 6V - US 250
	160933	BATTERY, 6V - AGM
BC1	122093	INDICATOR, Battery Charge
BP29	170620	BEEPER, All Motion, Tilt & Overload
C1	146475	CONTACTOR, Motor
CB1	117325	BREAKER, Circuit - 15A
CB2	408526	BREAKER, Circuit - 10A
CM1	217926	CONTROLLER, Skycoded Module
DCM1	169260	MOTOR
DXX	102921	DIODE
F1	310517	FUSE, 300A
F2	146442	FUSE, 100A - Inverter <b>(ANSI/CSA)</b>
FL-22	235775	LIGHT, Flashing
H1	146649	Horn
LS1	210226	LIMIT SWITCH, Pothole Protection - Hydraulic Tray Side
LS2	210227	LIMIT SWITCH, Pothole Protection - Battery Tray Side
LS7A	208038	LIMIT SWITCH, Anti-Overriding Posts - 64"
LS7B	208039	LIMIT SWITCH, Anti-Overriding Posts - 108"
LS7C	220080	LIMIT SWITCH, Anti-Overriding Posts - Additional Posts
LS7D	220080	LIMIT SWITCH, Anti-Overriding Posts - Additional Posts
PL-1	147061	LIGHT, Platform - Emergency Stop/Overload
PL-2	147061	LIGHT, Base - Emergency Stop/Overload
PT1	217934	TRANSDUCER, Pressure - 3000 PSI <b>(SJ3219)</b>
	217933	TRANSDUCER, Pressure - 2000 PSI <b>(SJ3215)</b>
S1	210051	SWITCH, Main Disconnect
S2	147054	SWITCH, Lift/Lower
S3	207741	SWITCH, Lift/Off/Drive
S4	147053	SWITCH, Platform - Emergency Stop
S5	220494	SWITCH, SGLE

Index No.	Skyjack Part No.	Description
S7	211751	JOYSTICK
S7-1	119725	SWITCH, Neutral
S7-2	159613	SWITCH, Right
S7-3	159613	SWITCH, Left
S7-6	159067	SWITCH, Enable
S8	147054	SWITCH, Horn
S10	149536	SWITCH, Key - Idle/Platform/Base <b>(ANSI/CSA, AS &amp; KC)</b>
	147057	SWITCH, Key - Idle/Platform/Base <b>(CE)</b>
S27	115574	SWITCH, Torque
S28	147053	SWITCH, Base - Emergency Stop
S51	212204	SWITCH, Emergency Lowering

### 3.6 Platform Control Box Wiring

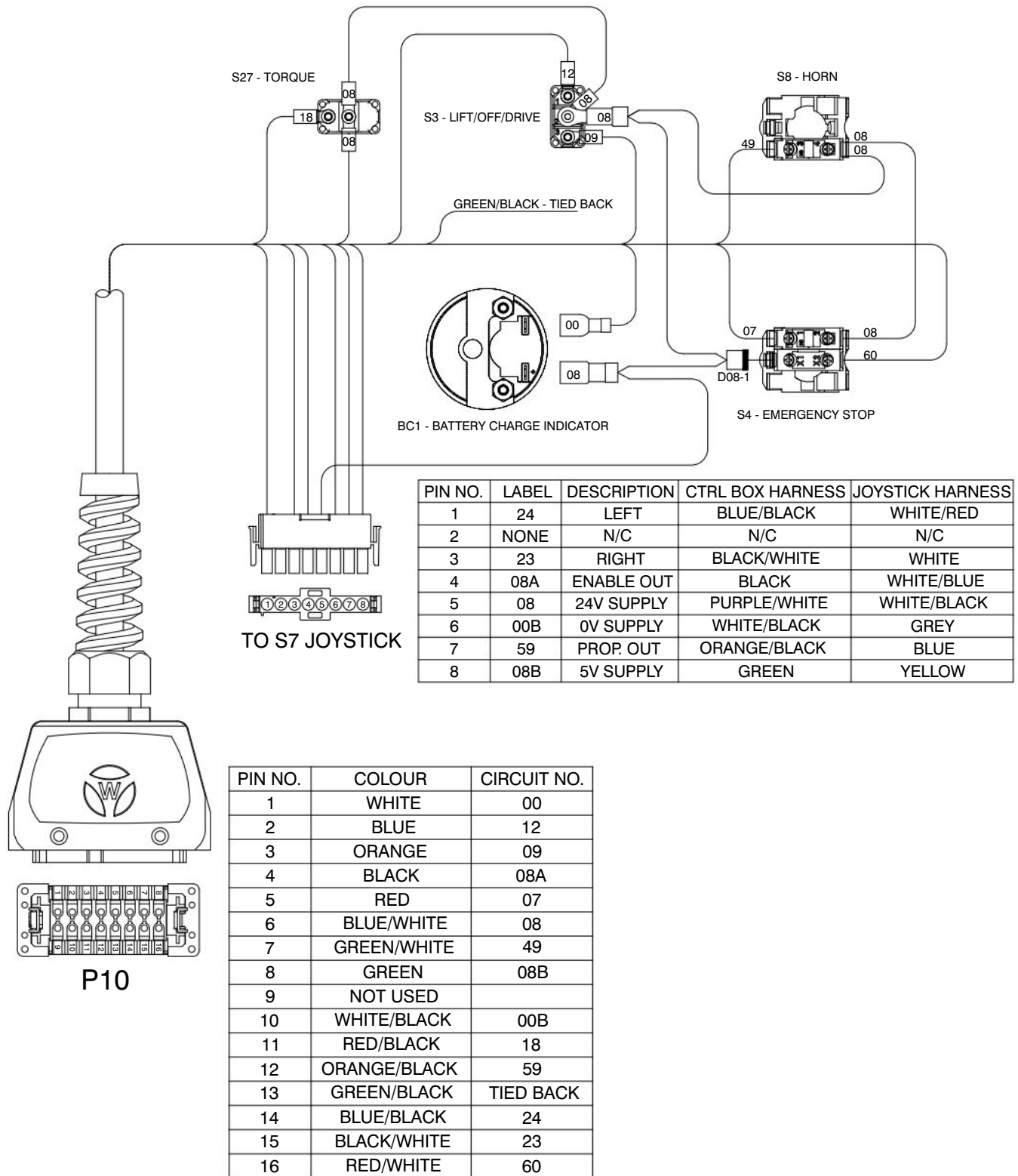



### 3.7 Platform Control Box Wiring - SGLE

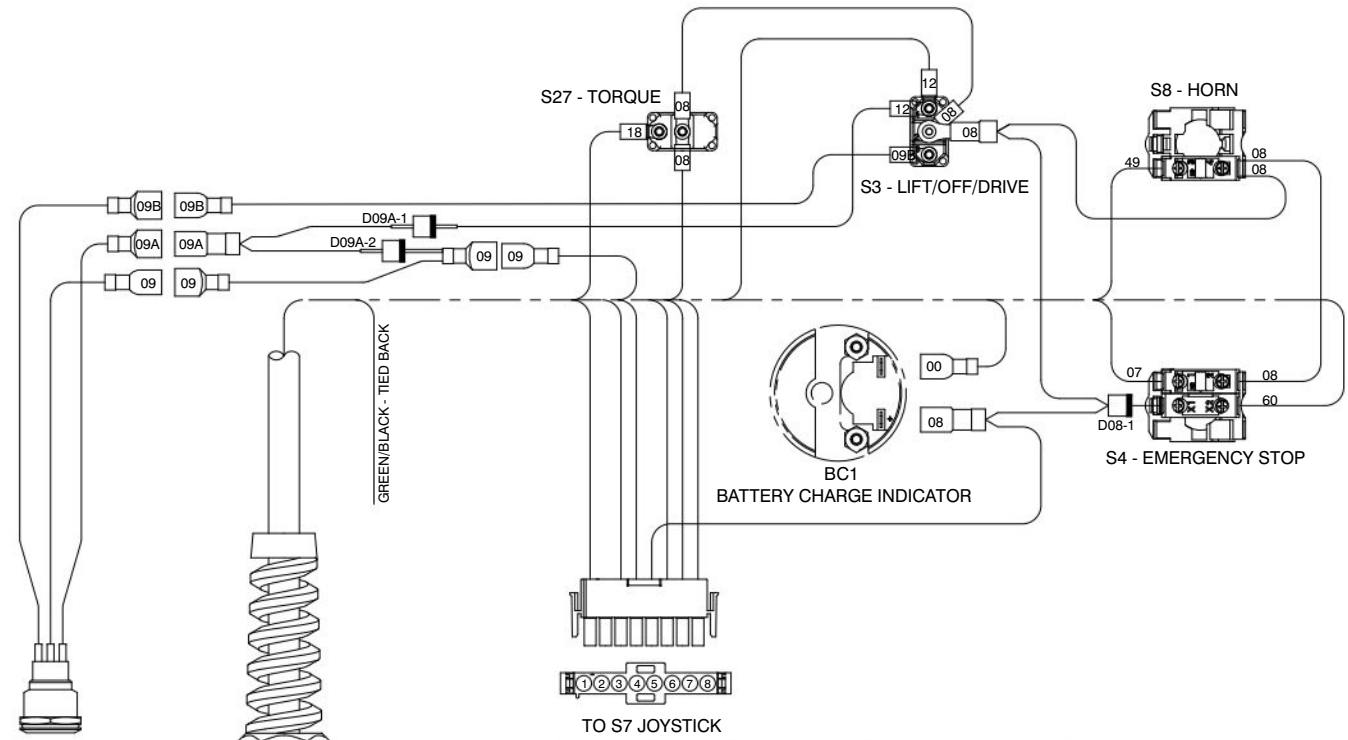

TO S7 JOYSTICK

PIN NO.	LABEL	DESCRIPTION	CTRL BOX HARNESS	JOYSTICK HARNESS
1	24	LEFT	BLUE/BLACK	WHITE/RED
2	NONE	N/C	N/C	N/C
3	23	RIGHT	BLACK/WHITE	WHITE
4	08A	ENABLE OUT	BLACK	WHITE/BLUE
5	08	24V SUPPLY	PURPLE/WHITE	WHITE/BLACK
6	00B	0V SUPPLY	WHITE/BLACK	GREY
7	59	PROP. OUT	ORANGE/BLACK	BLUE
8	08B	5V SUPPLY	GREEN	YELLOW

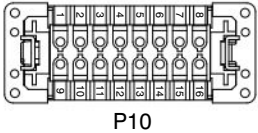

P10

PIN NO.	COLOUR	CIRCUIT NO.
1	WHITE	00
2	BLUE	12
3	ORANGE	09
4	BLACK	08A
5	RED	07
6	BLUE/WHITE	08
7	GREEN/WHITE	49
8	GREEN	08B
9	NOT USED	
10	WHITE/BLACK	00B
11	RED/BLACK	18
12	ORANGE/BLACK	59
13	GREEN/BLACK	TIED BACK
14	BLUE/BLACK	24
15	BLACK/WHITE	23
16	RED/WHITE	60

### 3.8 Base to Platform Control Cable

CAVITY NO.	COLOUR	CIRCUIT NO.
1	WHITE	00
2	BLUE	12
3	ORANGE	09
4	BLACK	08A
5	RED	07
6	BLUE/WHITE	08
7	GREEN/WHITE	49
8	GREEN	08B
9	NOT USED	
10	WHITE/BLACK	00B
11	RED/BLACK	18
12	ORANGE/BLACK	59
13	GREEN/BLACK	-
14	BLUE/BLACK	24
15	BLACK/WHITE	23
16	RED/WHITE	60

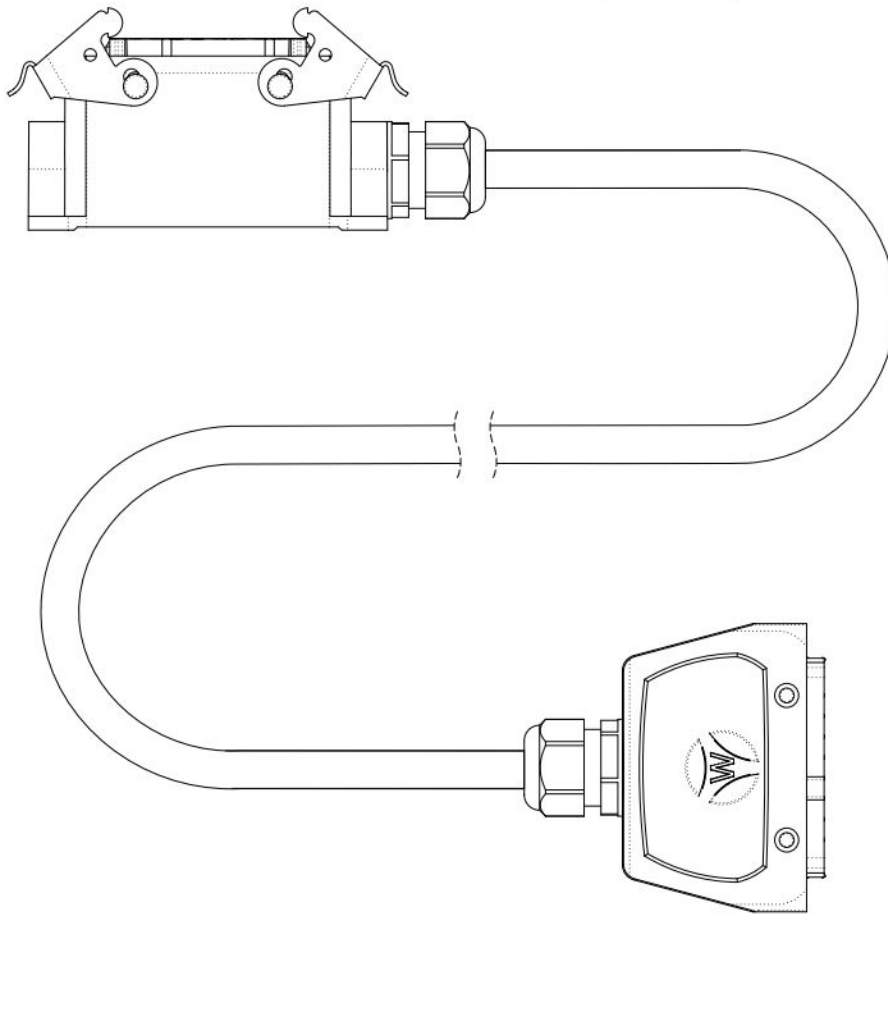
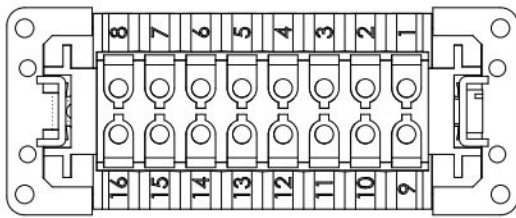

### 3.9 Base Control Wiring

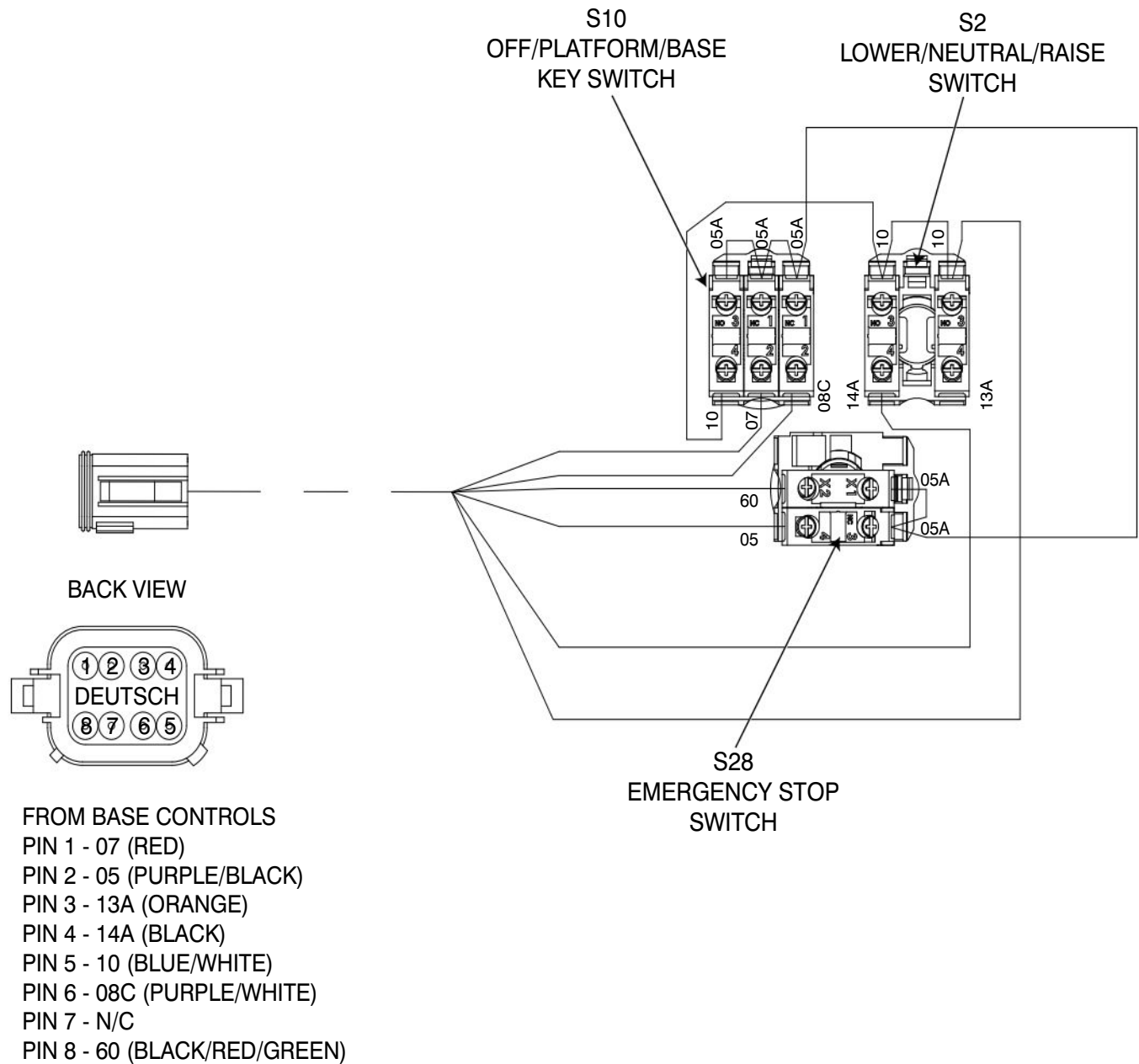

### 3.10 Emergency Lowering Switch Wiring

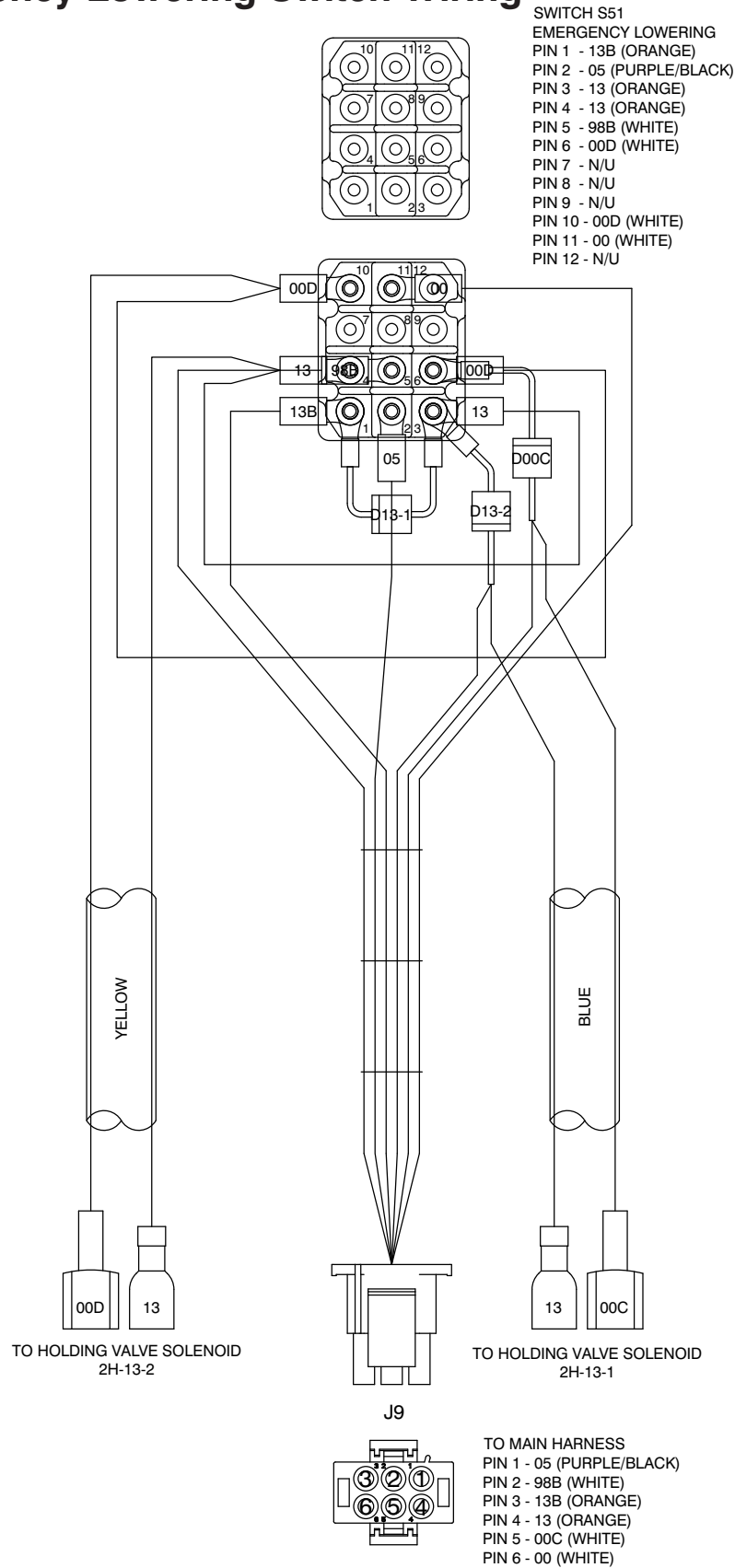

M212536AE

### 3.11 Pothole Limit Switch Wiring

#### Hydraulic Tray Side

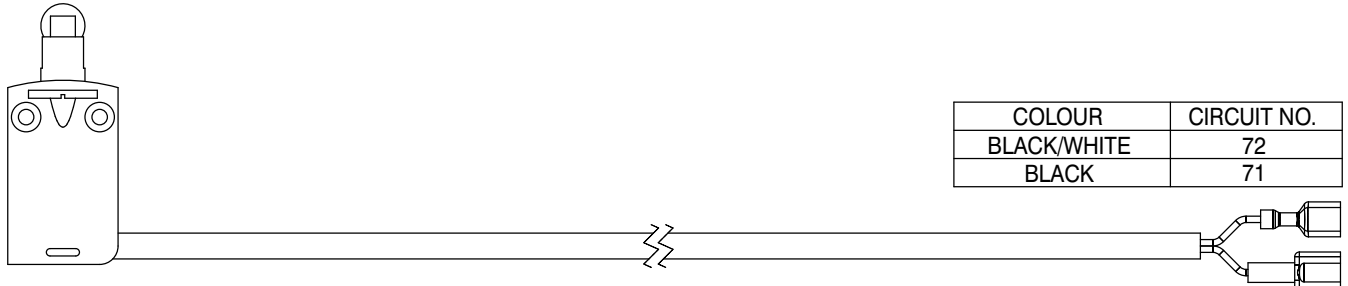

#### Battery Tray Side

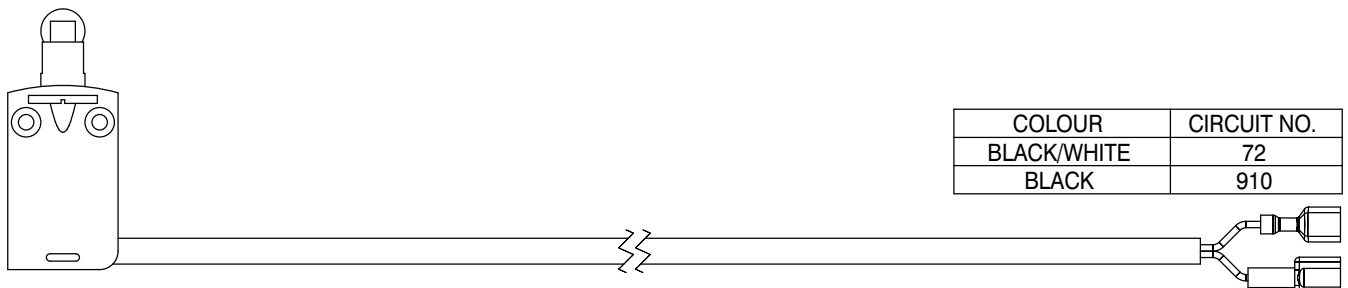

### 3.12 Holding Valve and Pressure Transducer Harnesses

#### Holding Valve Harness

LABEL	TERMINAL	COLOUR
13	1	BLACK (+12 VDC)
00C	2	WHITE (GND)

LABEL	TERMINAL	COLOUR
13	1	BLACK (+12 VDC)
00D	2	WHITE (GND)

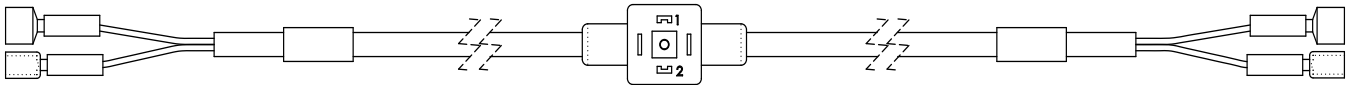

#### Pressure Transducer Harness

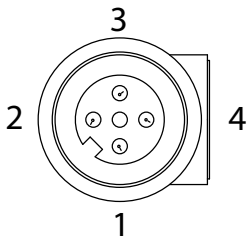
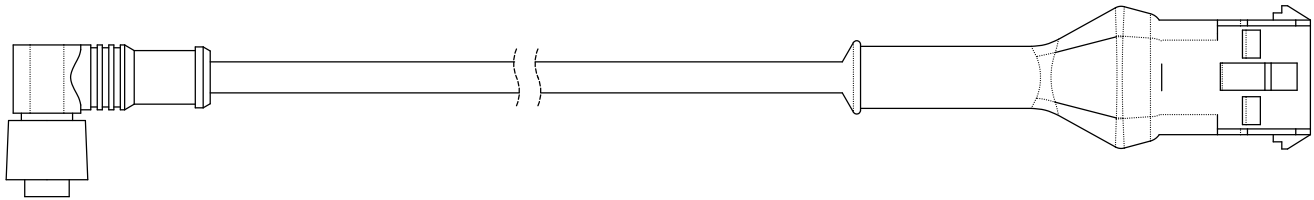

M12 CONNECTOR	MOLEX CONNECTOR	WIRE COLOUR
PIN 1	PIN 1	BROWN
PIN 2	NOT USED	-
PIN 3	PIN 3	BLUE
PIN 4	PIN 2	BLACK

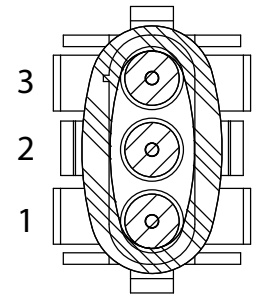

### 3.13 Battery Management System Harness

#### BMS Harness

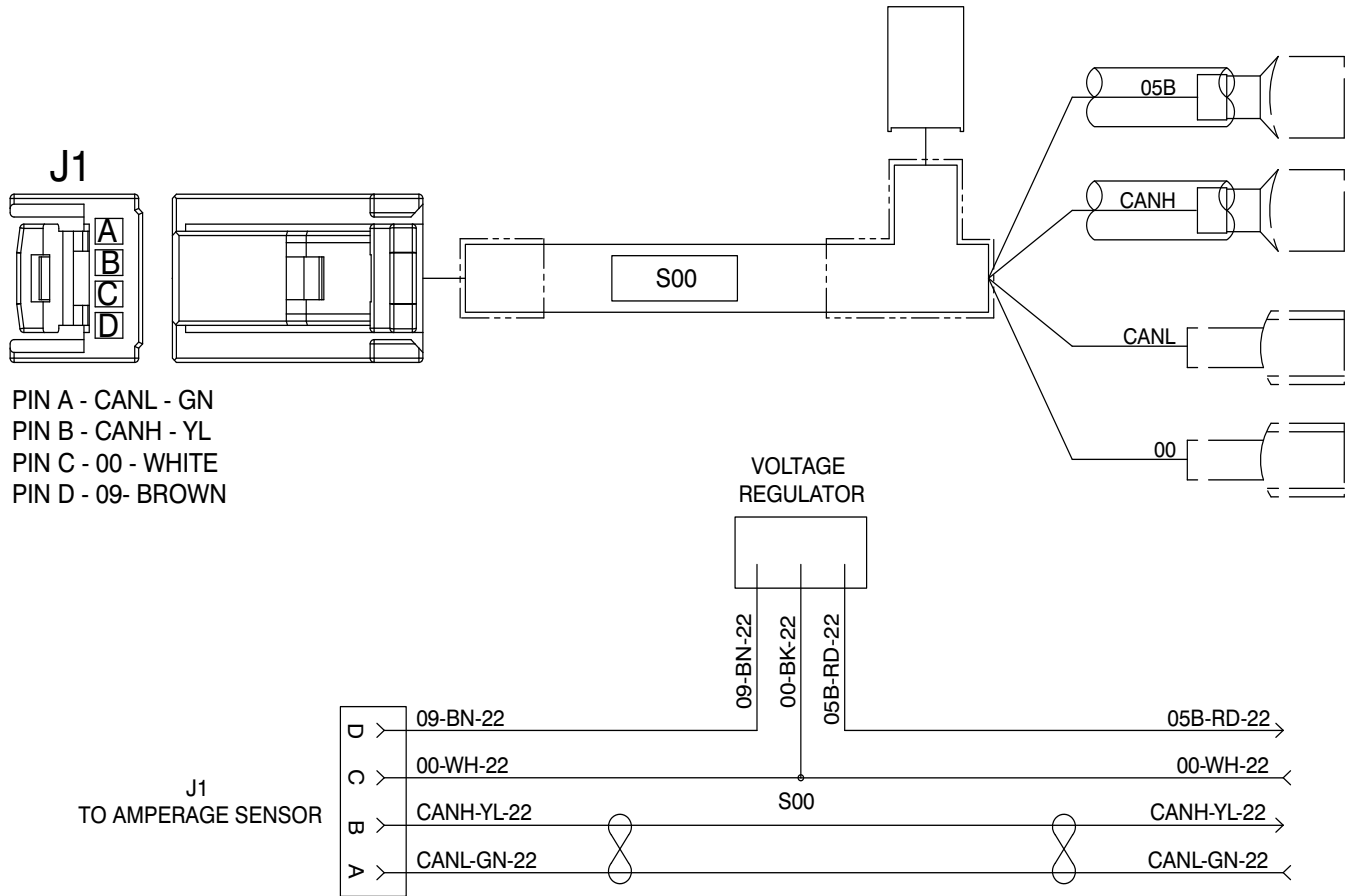

### 3.14 Anti-Overriding Limit Switch Wiring (KC Only)

#### Anti-Overriding Posts Limit Switches

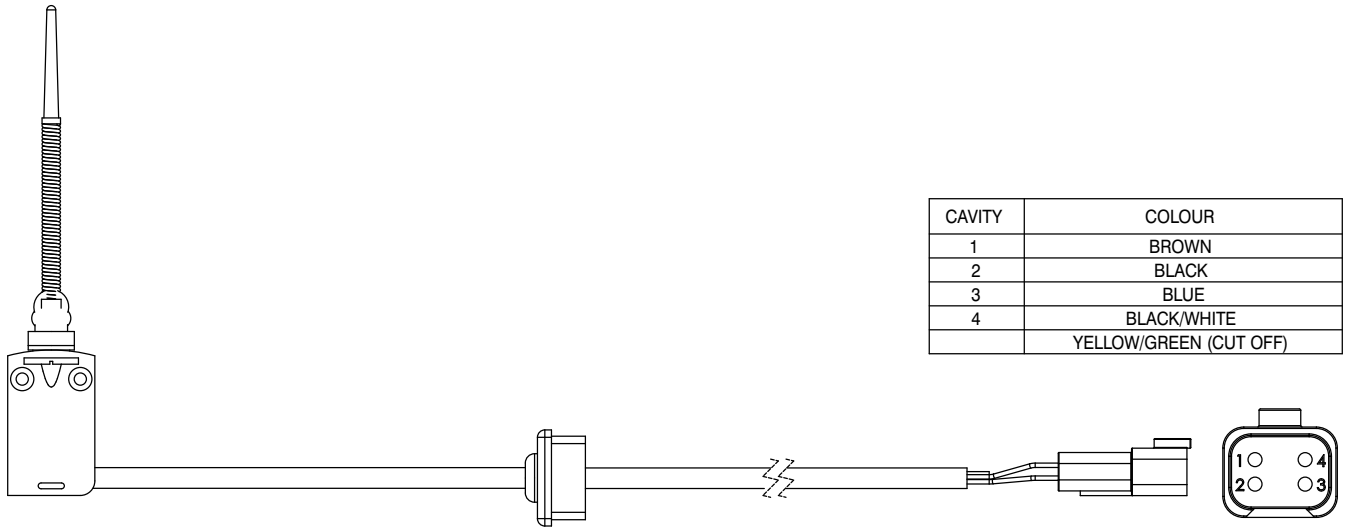

#### Anti-Overriding Posts Limit Switches - Add 2 Posts

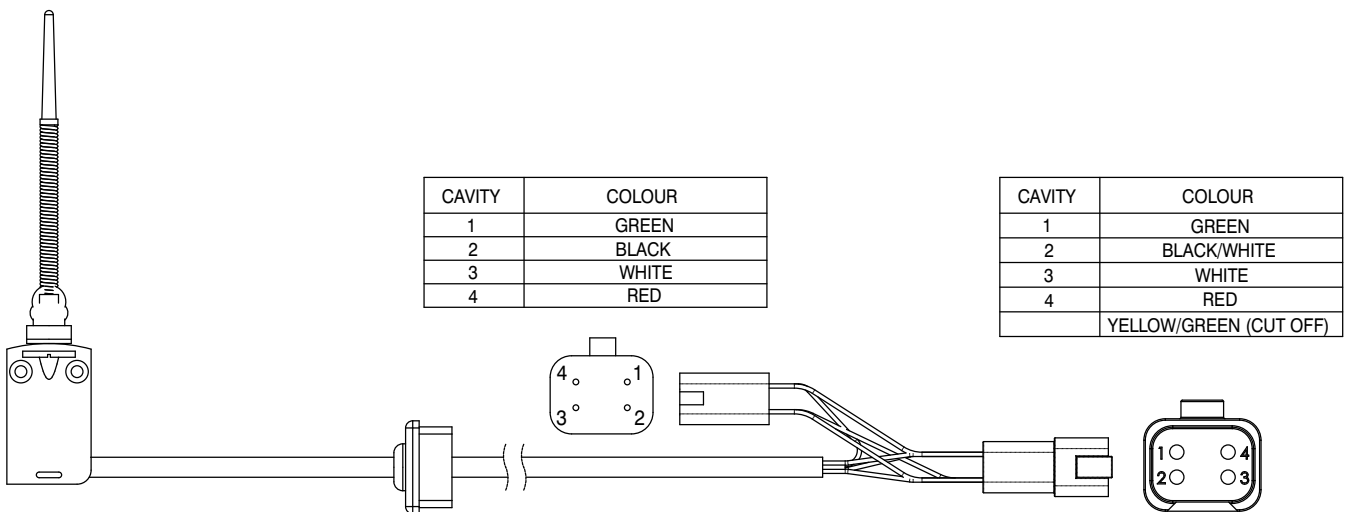



### 3.15 Anti-Overriding Limit Switch Harness (KC Only)

#### Anti-Overriding Posts - Scissor Harness

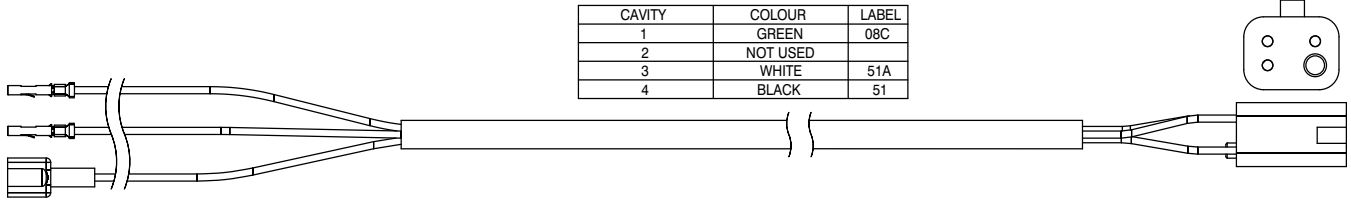

#### Anti-Overriding Posts - Platform Harness

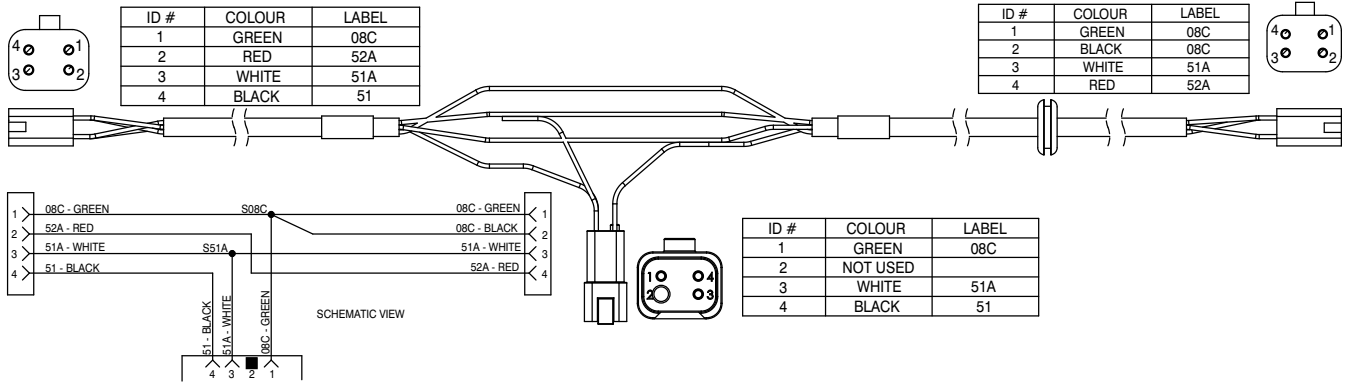

### 3.16 Free-Wheeling Manifold MB2

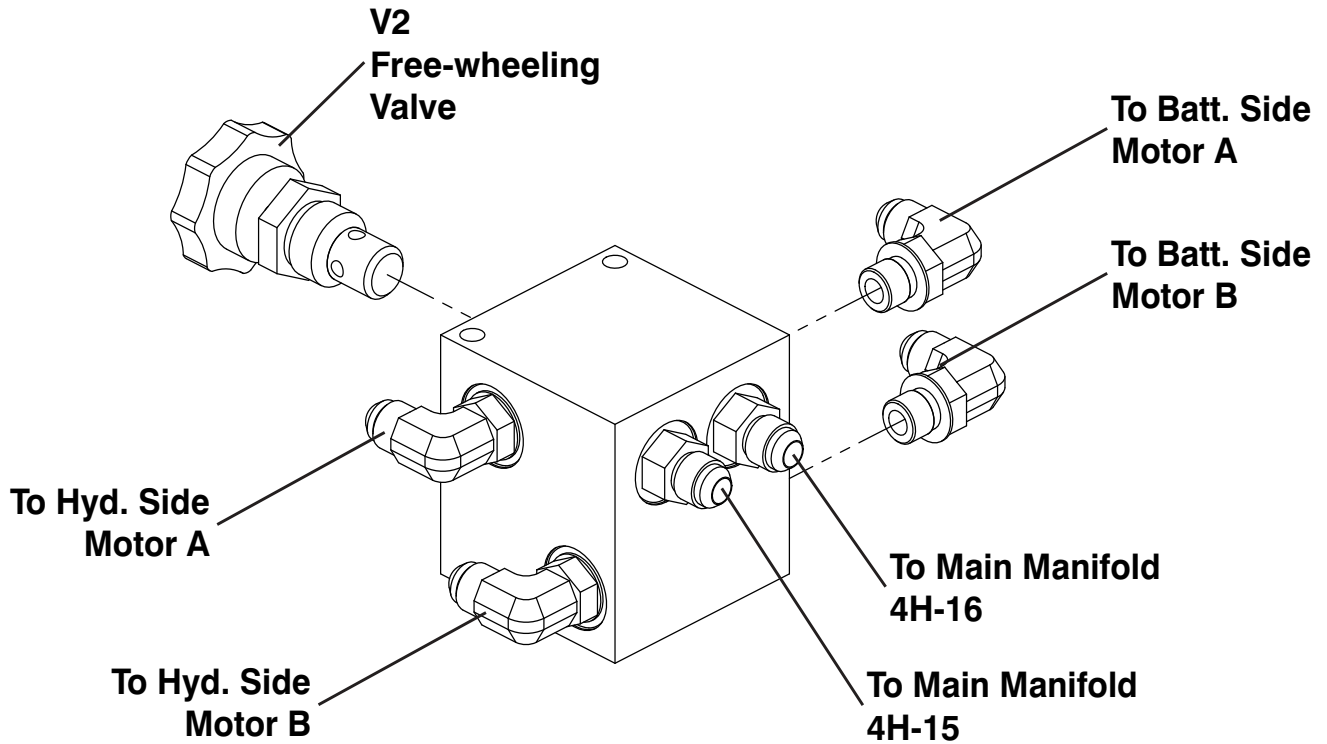

### 3.17 Brake Manifold MB4 (CE, AS & KC)

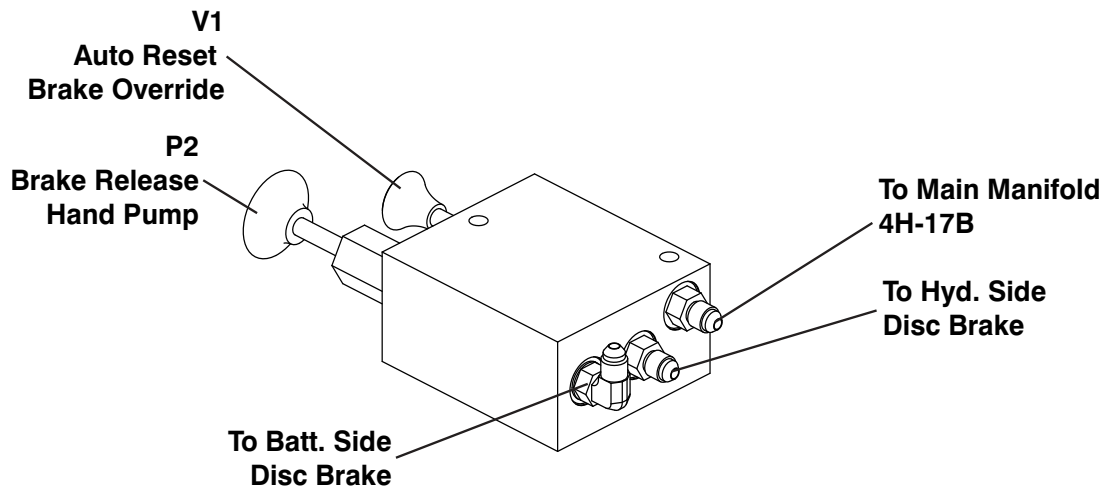

M138021AE\_SJ321X\_Service, M196578AD\_BrakeMan

### 3.18 Lift Cylinder Manifold MB3

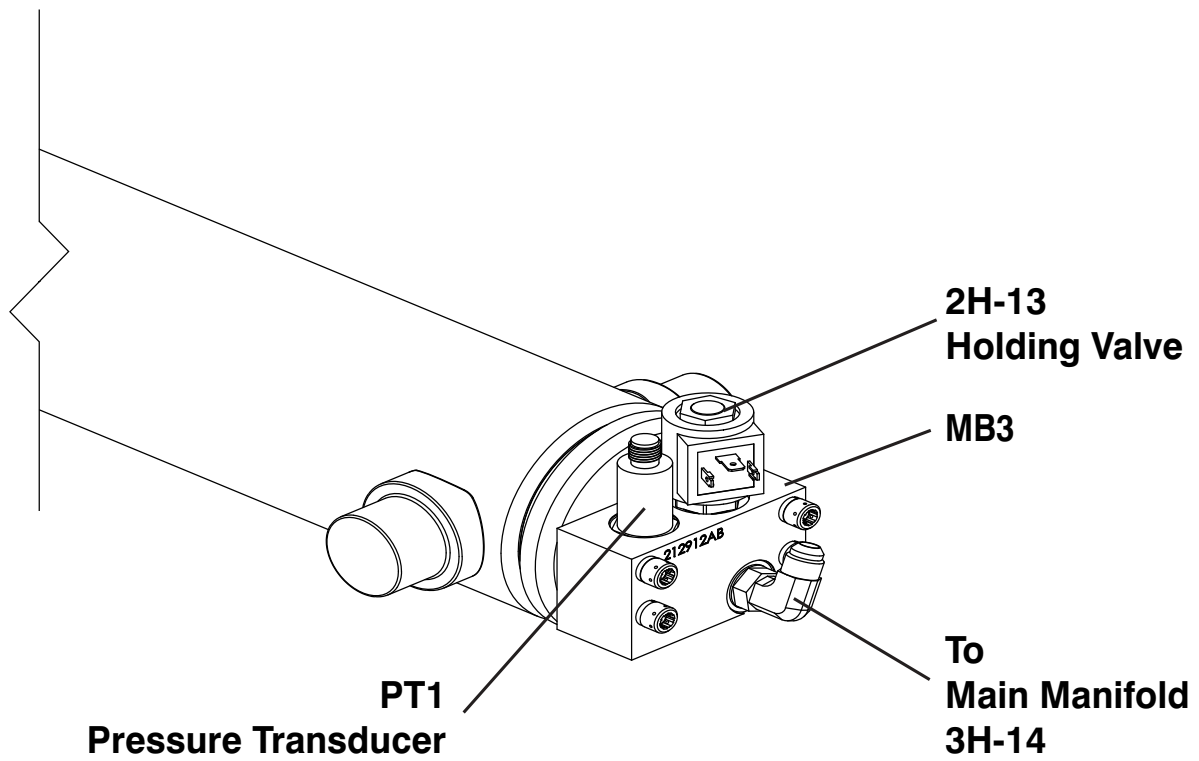



### 3.19 Major Component Identification

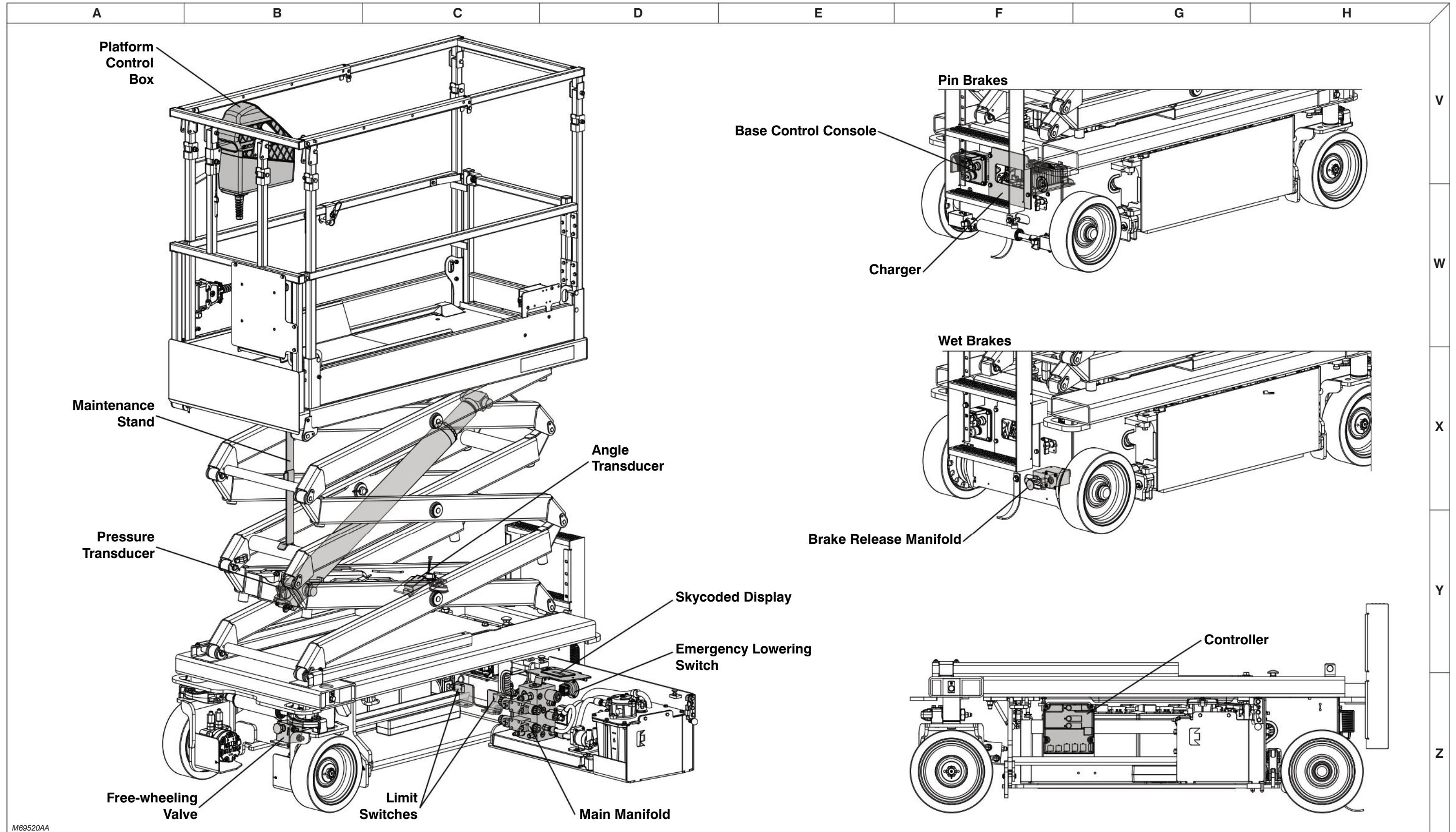

M69520AA



### 3.20 Main Manifold MB1

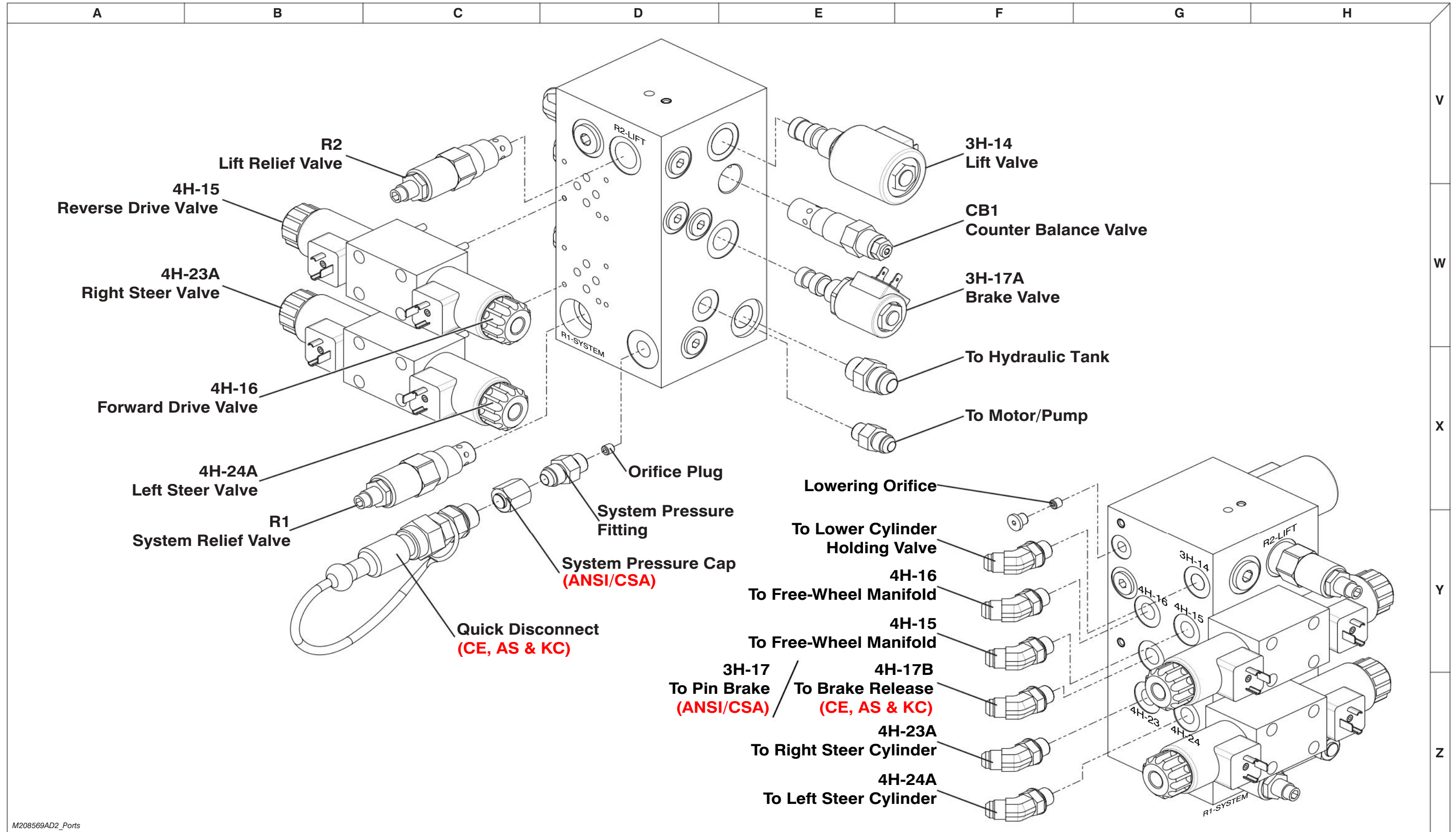

M208569AD2\_Ports

### 3.21 Hydraulic Schematics - SJ3215 ANSI/CSA

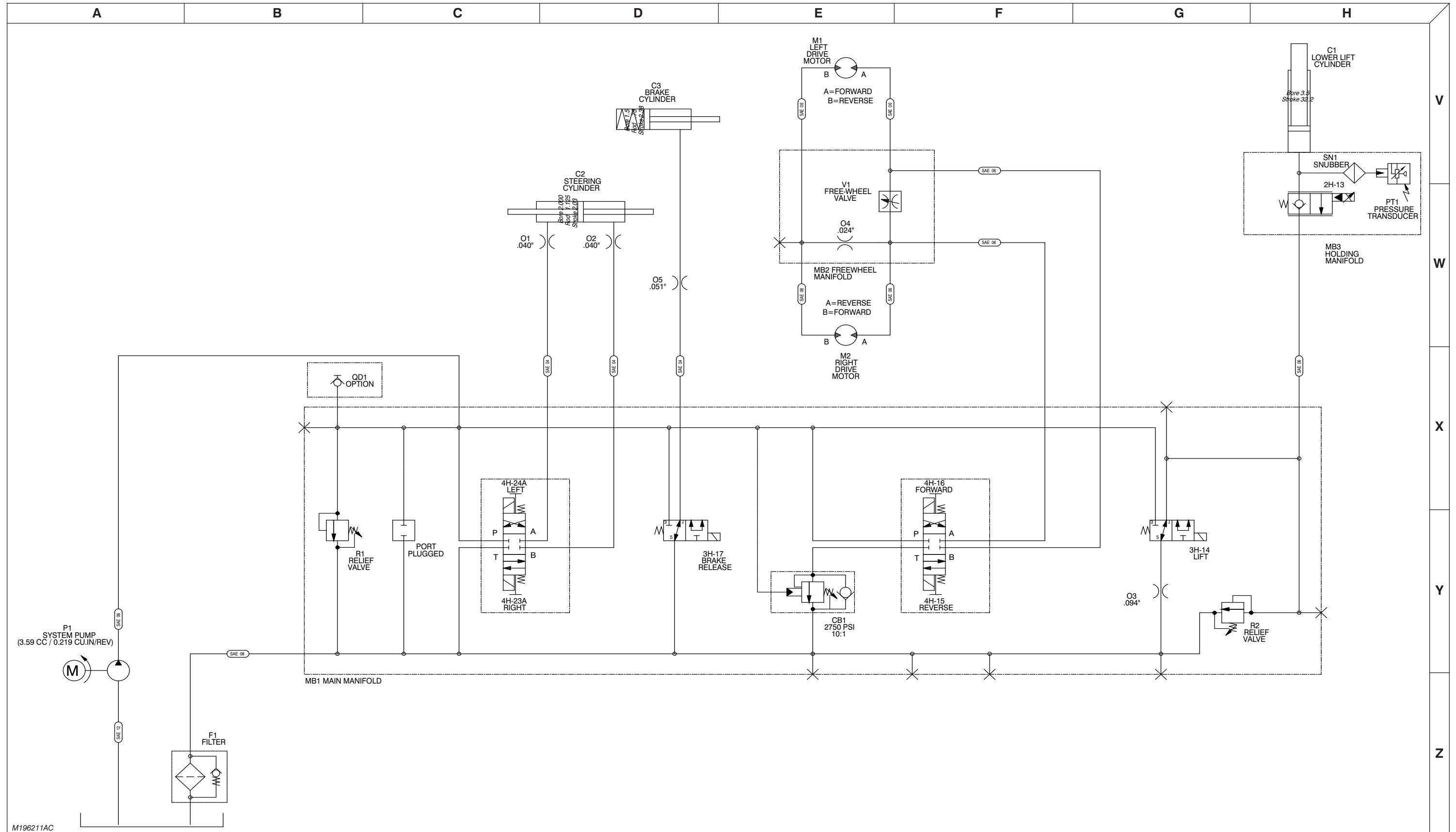

M196211AC

### 3.22 Hydraulic Schematics - SJ3215 CE, AS & KC

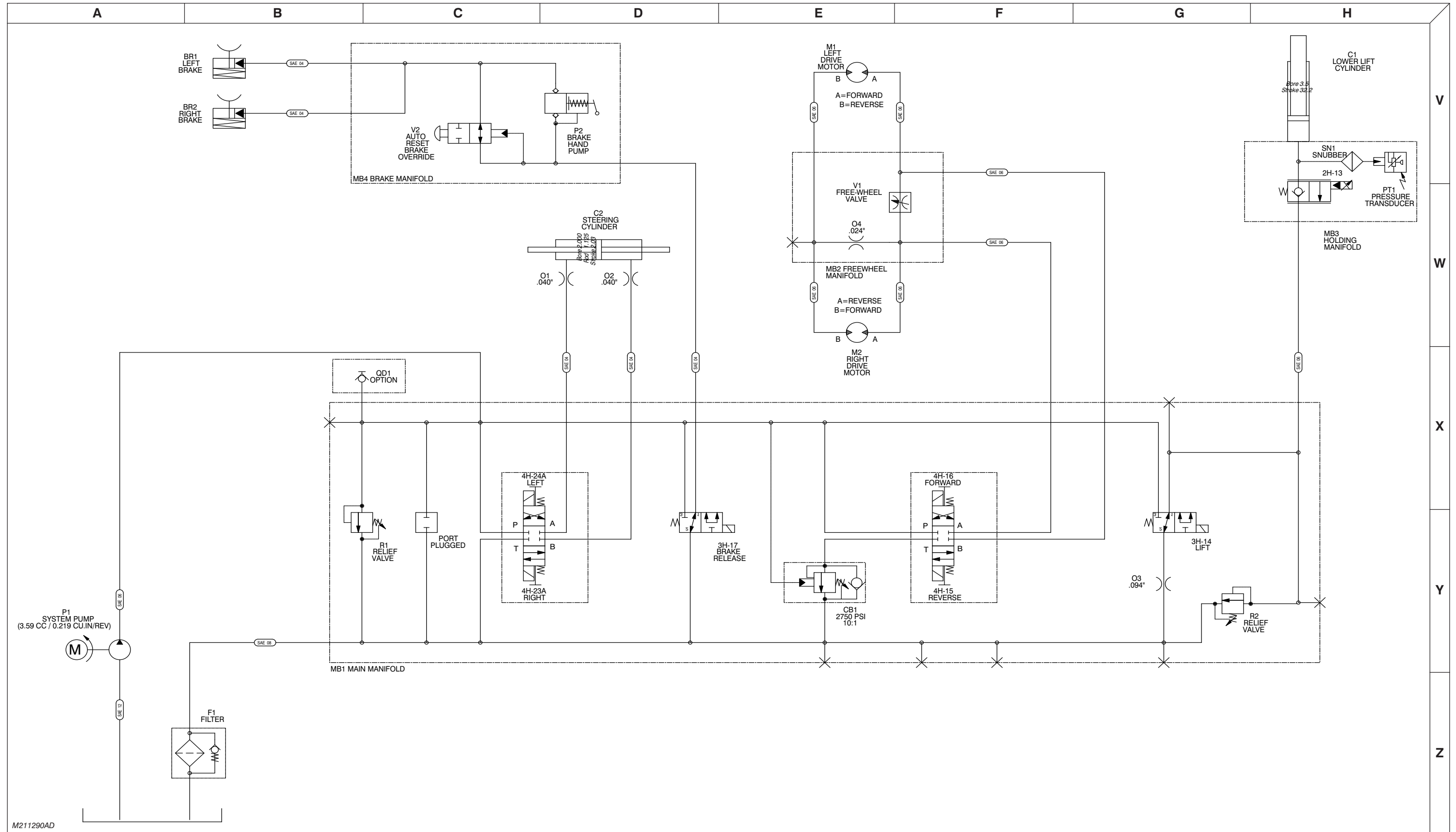

M211290AD



### 3.23 Hydraulic Schematics - SJ3219 ANSI/CSA

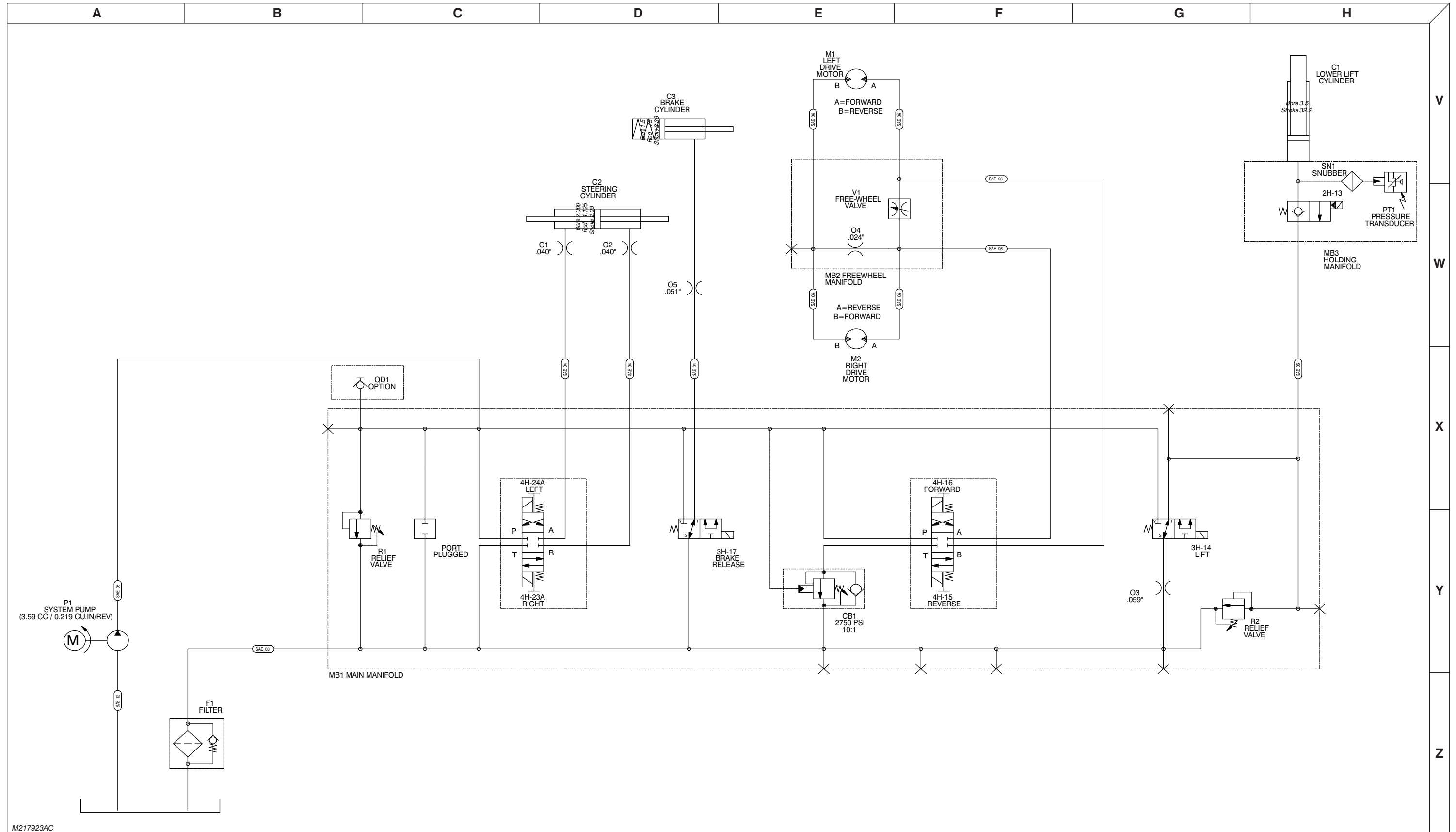

M217923AC

### 3.24 Hydraulic Schematics - SJ3219 CE

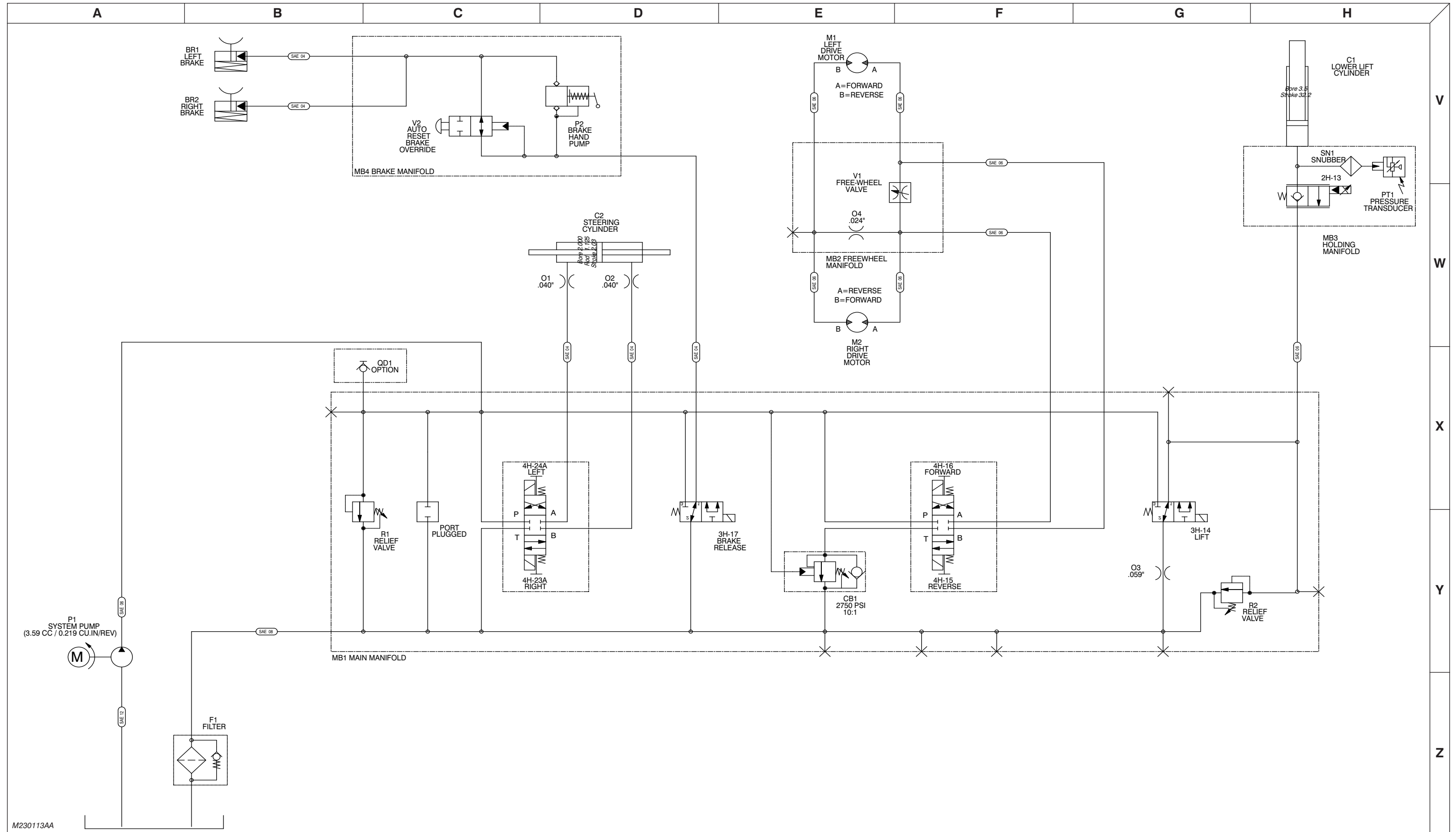

M230113AA

### 3.25 Hydraulic Schematics - SJ3219 AS & KC

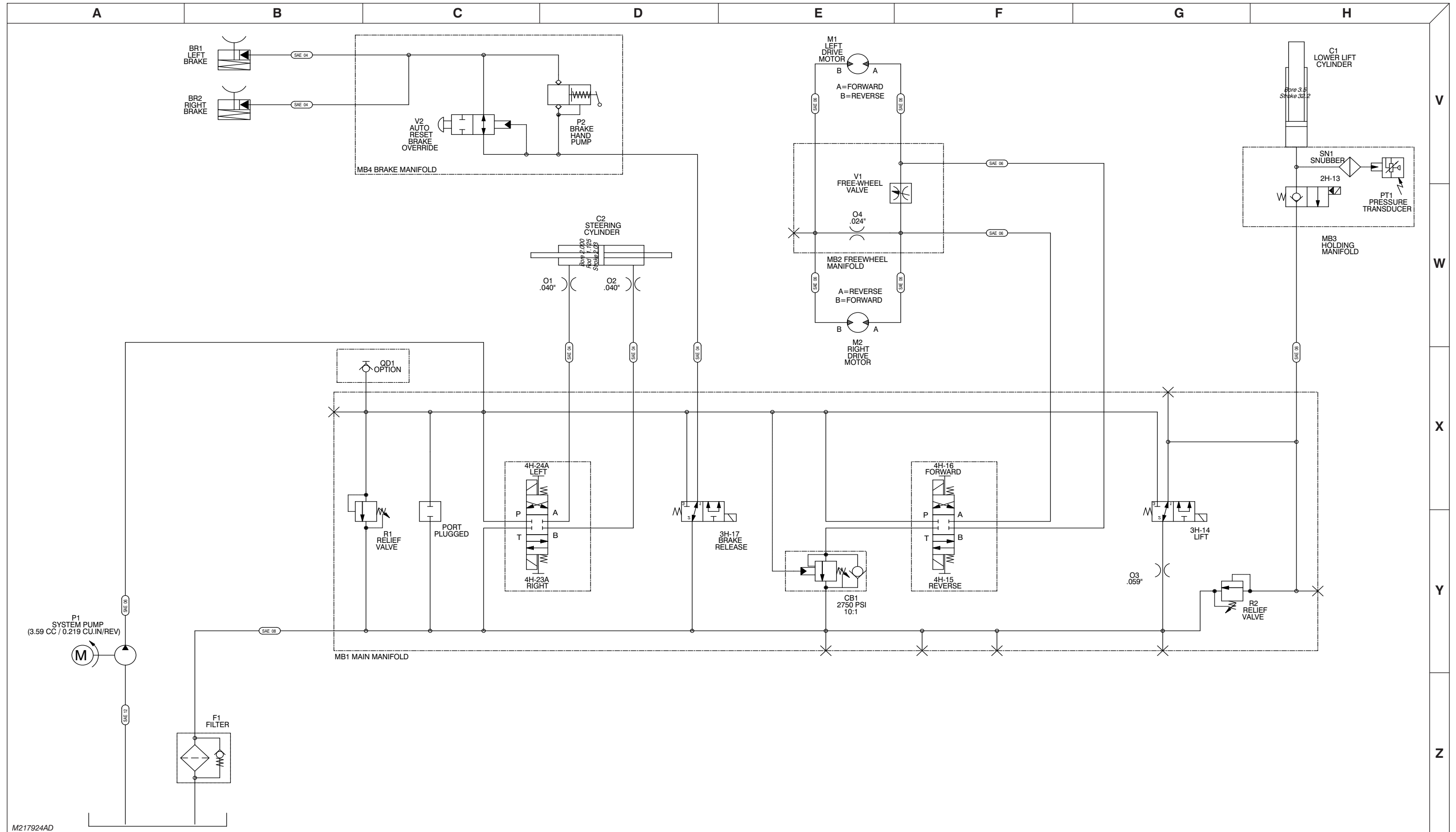

M217924AD

### 3.26 Elevate Telematics Harness

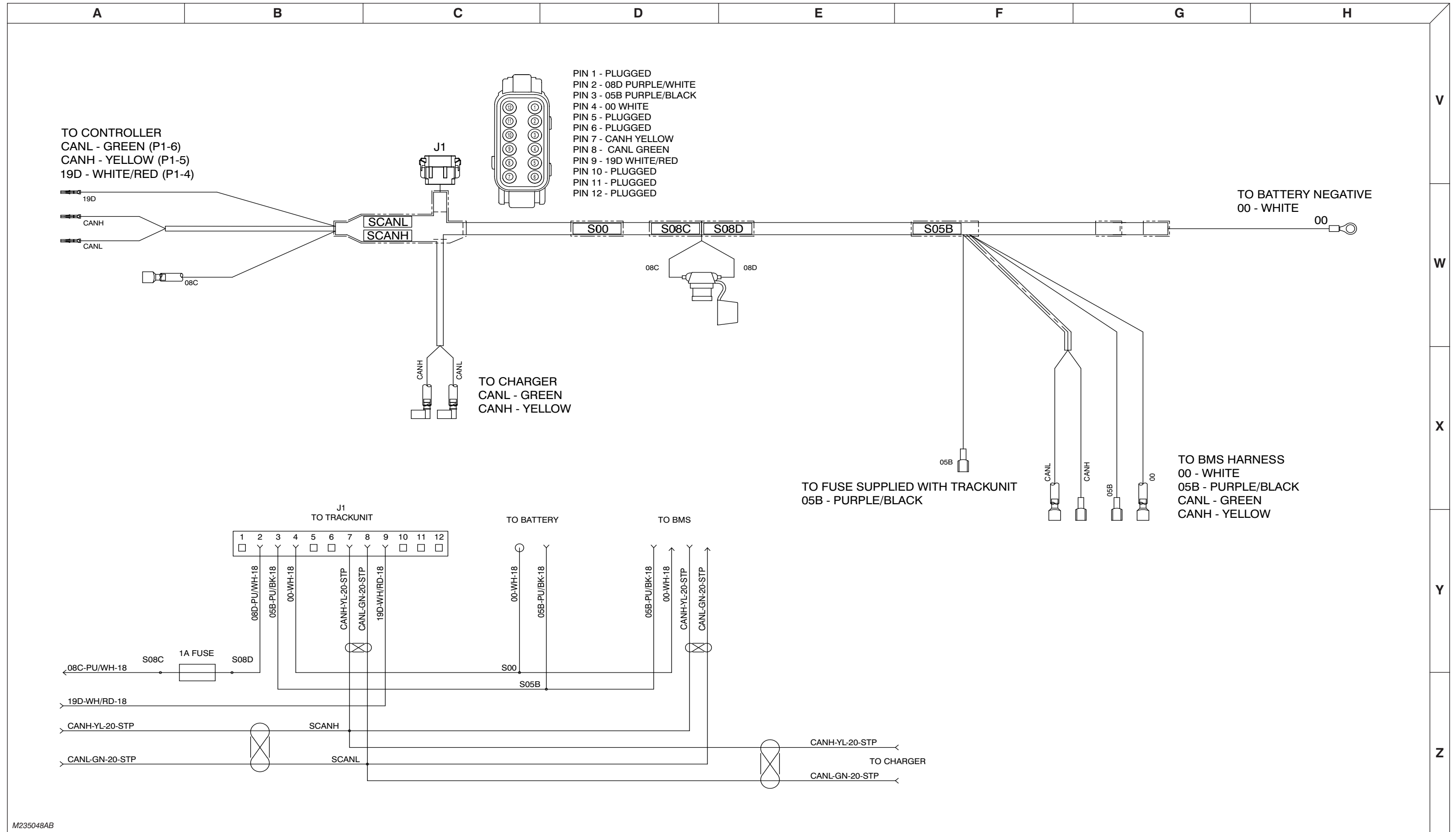

M235048AB

### 3.27 Electrical Schematic - ANSI/CSA

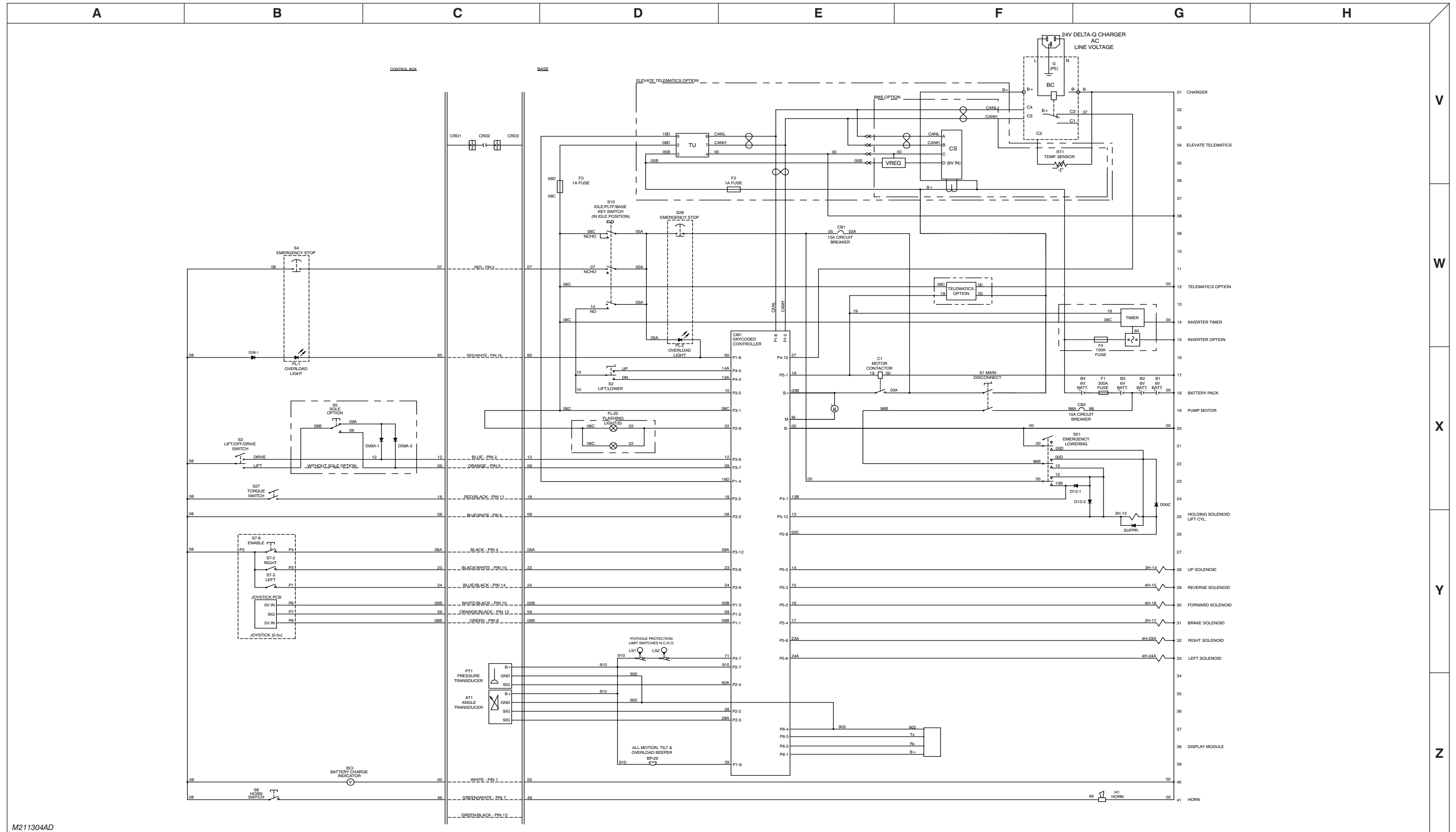

M211304AD

### 3.28 Electrical Schematic - CE

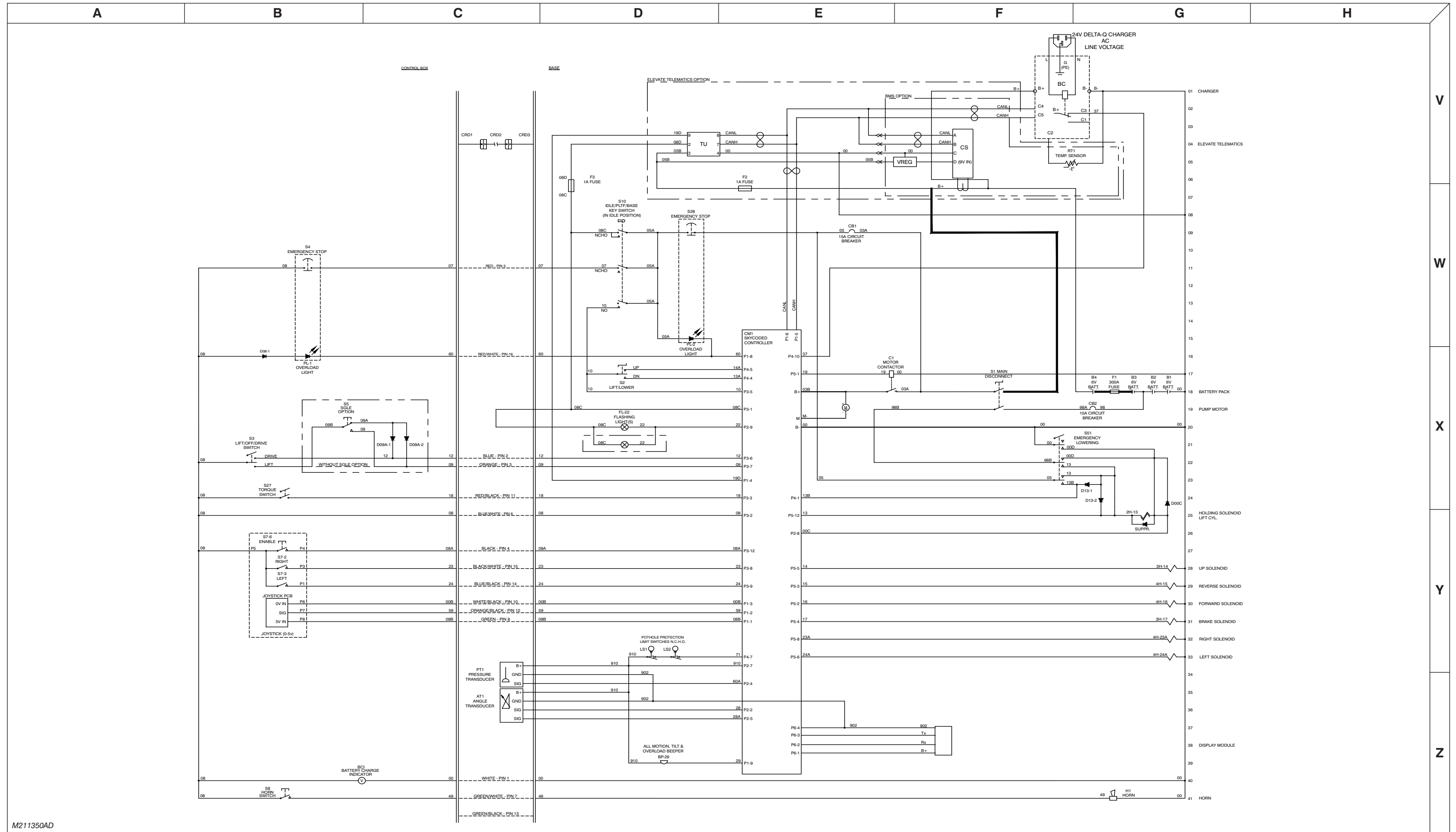

M211350AD

### 3.29 Electrical Schematic - AS

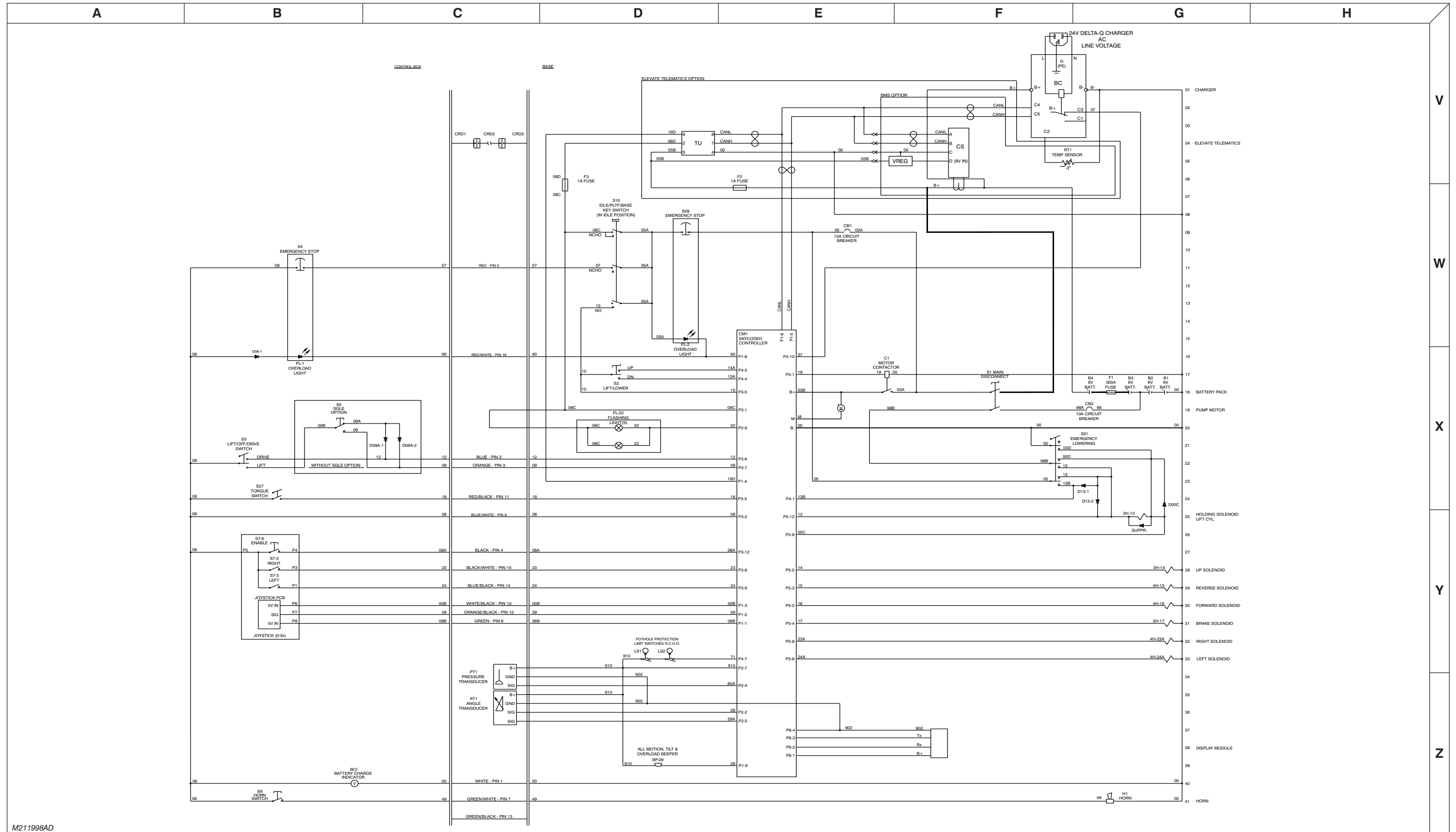

M211998AD

### 3.30 Electrical Schematic - KC

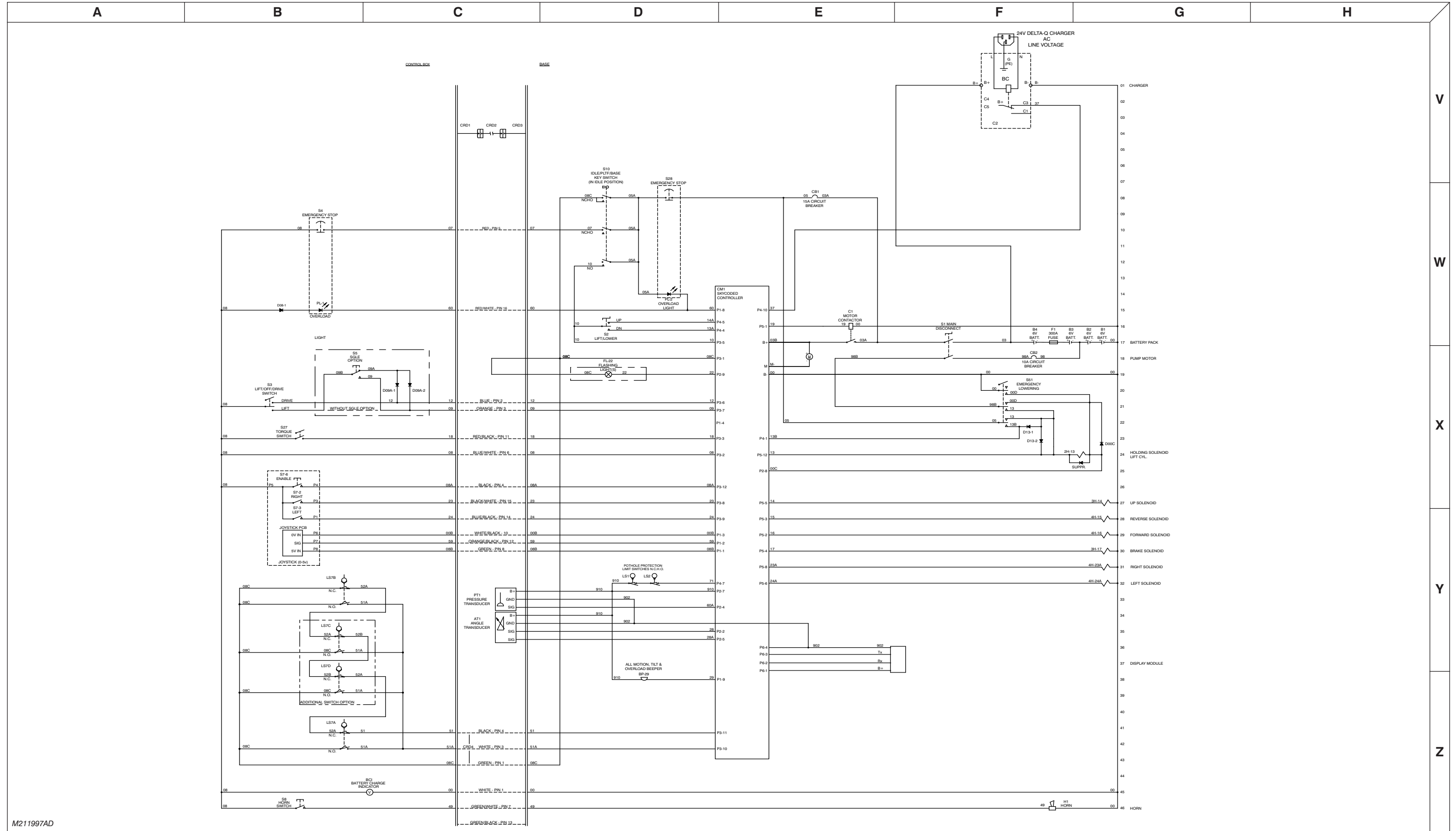

M211997AD



3.30 Main Harness

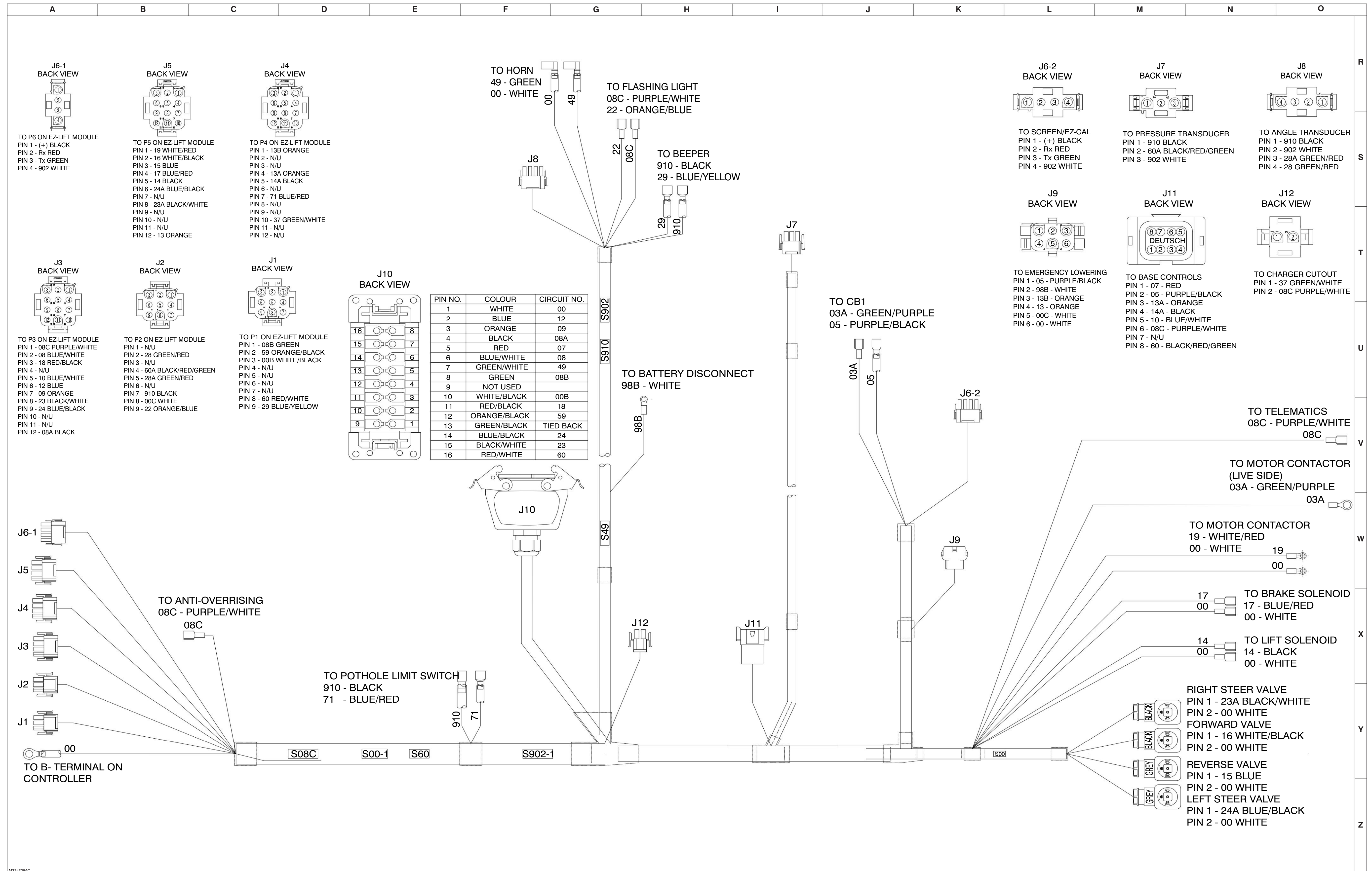

M22425AC

### 3.30 Main Harness Wiring

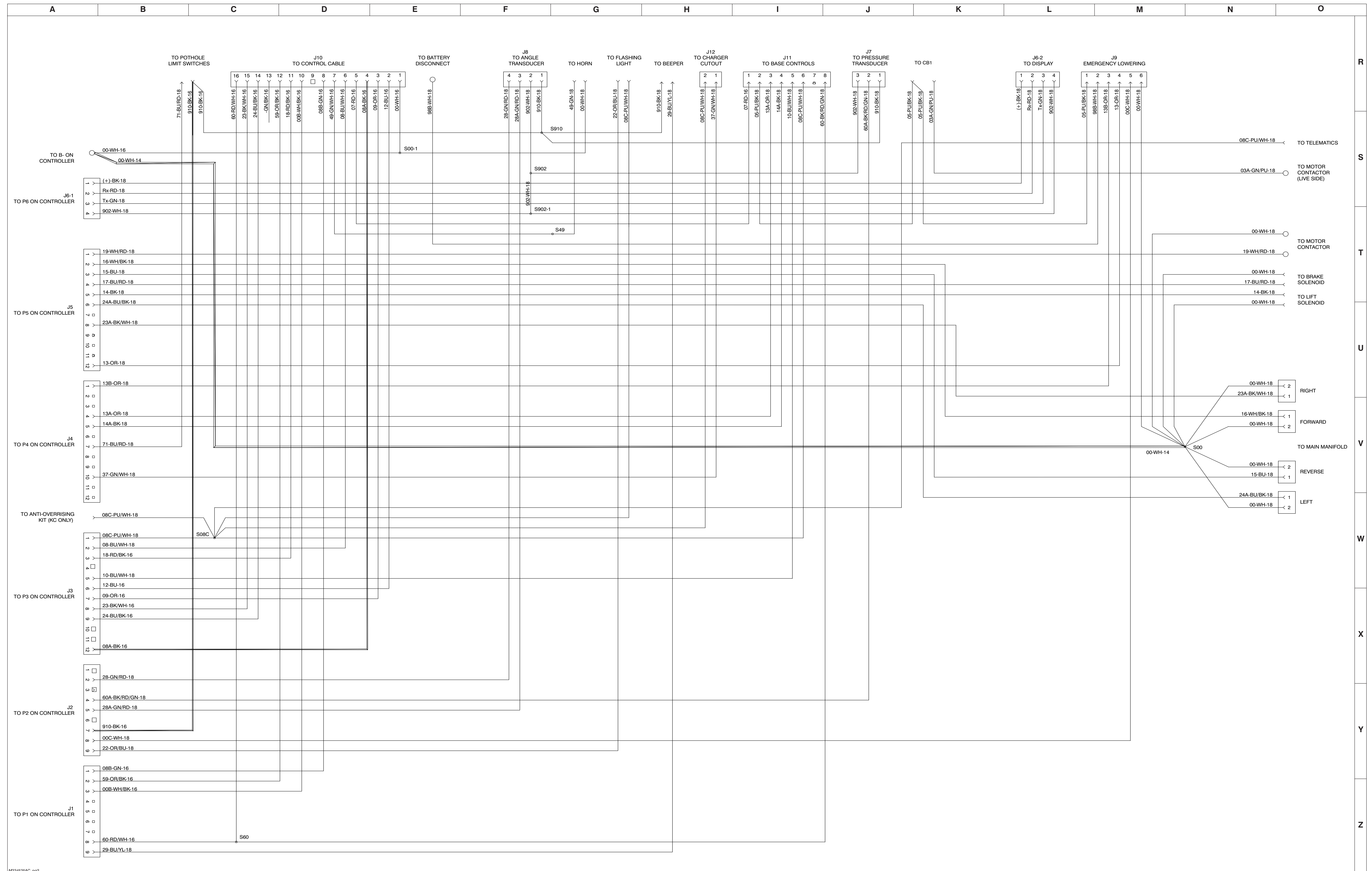

M224525AC\_pg2



---

# Section 4 – Troubleshooting Information

## 4.1 Introduction

The following pages contain a table of Troubleshooting for locating and correcting most service trouble which can develop. Careful and accurate analysis of the systems listed in the table of Troubleshooting will localize the trouble more quickly than any other method. This manual cannot cover all possible troubles and deficiencies that may occur. If a specific trouble is not listed, isolate the major component in which the trouble occurs, isolate whether the problem is electrical or hydraulic, and then isolate and correct the specific problem.

The content of this section is separated into “probable cause” and “remedy.” The information in the left-hand column, preceded by a number, represents the “probable cause.” The information in the right-hand column, in bold text, represents the “remedy” to the “probable cause” directly beside it. See the example below for clarification.

---

1. Probable cause

**Remedy**

---



## 4.2 Electrical System

### 4.2-1 All Controls Inoperative

1. Control Module CM1 display is broadcasting an error message.	<b>Check Control Module display screen and follow instructions to clear error.</b>
2. Battery charger plugged into external power source.	<p><b>Disconnect charger cord.</b></p> <p><b>(if equipped with Delta Q Charger) Check continuity between wire #B+ and wire #37 on Delta Q Charger to test the N.C. contact in Battery Charger Cutoff Relay L1CR</b></p> <p><b>(if equipped with other charger) Check continuity between wire #08C and wire #37 on other Charger to test the N.C. contact in the Battery Charger Cutoff Relay L1CR.</b></p> <p><b>Replace charger if contact is not closed when unplugged from external power source</b></p> <p><b>Check continuity of wire #37 from Battery Charger Cutoff Relay L1CR to Control Module CM1 pin #P4-10</b></p> <p><b>Use HMI Diagnostic menu to make sure Input P4-10 signal is present.</b></p>
3. Batteries disconnected or faulty.	<b>Connect batteries and test each battery for proper supply voltage</b>
4. Dirty or loose battery terminals.	<b>Clean and tighten connections.</b>
5. Battery charge low.	<p><b>Check each cell with a hydrometer. Reading should be 1.275 (fully charged).</b></p> <p><b>Recharge if low reading.</b></p> <p><b>Replace if reading difference between cells is 0.050.</b></p>
6. Main battery cables open or defective.	<b>Check continuity. Replace if defective.</b>
7. Fuse F1 defective or open.	<b>Replace fuse.</b>
8. Main battery disconnect switch S1 open or defective.	<p><b>Close switch.</b></p> <p><b>Check continuity between wire #03 and wire #03A on switch.</b></p> <p><b>Check continuity between wire #98A and wire #98B on switch.</b></p> <p><b>Replace switch if no continuity between either one of the switch poles.</b></p>
9. Loose or broken wires from fuse F1 to Battery to Main Disconnect S1	<b>Check continuity to #03A. Replace if defective.</b>

10. Loose or broken wire #03A to circuit breaker CB1 or circuit breaker is open	<b>Check continuity to circuit breaker. Test circuit breaker CB1. Replace if defective.</b>
11. Loose or broken wire #05 to base Emergency Stop switch S28.	<b>Check continuity. Replace if defective.</b>
12. Open or defective Base Emergency Stop switch S28.	<b>Close switch. Check continuity between wire #05 and wire #05A on switch. Replace if defective.</b>
13. Loose or broken wire #05A from Base Emergency Stop switch S28 to Base Key switch S10	<b>Check continuity. Replace if defective.</b>
14. Open or defective Base Key switch S10.	<b>Select function with switch. Check continuity between wire #05A and wire #08C on switch. (Base or Platform selected) Check continuity between wire #05A and wire #07 on switch. (Platform selected) Check continuity between wire #05A and wire #10 on switch. (Base selected) Replace switch if no continuity during correct switch function.</b>
15. Loose or broken wire #08C from Base Key switch S10 to Control module CM1 pin #P3-1.	<b>Check continuity. Test for 24V supply voltage between wire #08C and wire #00. Use HMI Diagnostic menu to make sure input P3-1 signal is present. Replace if defective.</b>
16. Loose or broken wire #07 from Base Key switch S10 to platform Emergency Stop switch S4.	<b>Check continuity. Replace if defective.</b>
17. Open or defective platform Emergency Stop switch S4.	<b>Close switch. Check continuity between wire #07 and wire #08 on switch. Replace if defective.</b>
18. Loose or broken wire #08 from platform Emergency Stop switch S4 to Control module CM1 pin #P3-2.	<b>Check continuity. Test for 24V supply voltage between wire #08 and wire #00. Use HMI Diagnostic menu to make sure Input P3-2 signal is present. Replace if defective.</b>
19. Loose or broken B- cable wire #00 from batteries to B- lug on Control module CM1.	<b>Check continuity. Replace if defective.</b>
20. External or internal fault detected by Control Module CM1.	<b>Check Control Module display screen. Use Diagnostic Menu to see switch and sensor status. Correct trouble code as displayed. Replace module if defective.</b>

## 4.2-2 All Controls Except for Down Function Inoperative

1. Control Module CM1 display is broadcasting an error message.	<b>Check Control Module display screen and follow instructions to clear error.</b>
2. Loose or broken wire #19 from Control module CM1 pin P5-1 to Motor contactor C1.	<b>Check continuity. Test for 24V Output voltage between wire #19 and wire #00. Use HMI Diagnostic menu to make sure Output P5-1 signal is present. Replace if defective.</b>
3. Loose or broken wire #00 from Motor Contactor C1 to Battery (-).	<b>Check continuity. Replace if defective.</b>
4. Loose or broken wire #03A from Main Disconnect switch S1 to Motor Contactor C1 N.O. contact.	<b>Check continuity. Replace if defective.</b>
5. Motor Contactor C1 not functioning	<b>Check that Motor Contactor C1 coil is energized when signal on wire #19 from Control Module CM1 pin #P5-1 to Motor Contactor C1 is enabled. Check continuity between wire #03A and #03B on the N.O. contact when Motor Contactor C1 coil is energized (or operating a function that provides B+ to Control Module CM1 pin #P5-1 from Motor Contactor C1 on wire #03B). Replace contactor if defective</b>
6. Loose or broken B- cable wire #00 from batteries to B- lug on Control Module CM1.	<b>Check continuity. Replace if defective.</b>
7. Loose or broken wire #M- from M lug on Control Module CM1 to Motor DCM1.	<b>Check continuity. Replace if defective.</b>
8. Loose or broken wire #03B from B+ lug on Control module CM1 to Motor DCM1.	<b>Check continuity. Replace if defective.</b>
9. Defective Motor DCM1.	<b>Supply the Motor DCM1 with 24 volt supply and a B- across motor to check operation of Motor DCM1. Replace if defective.</b>
10. External or internal fault detected by Control Module CM1	<b>Check Control Module display screen. Use Diagnostic Menu to see switch and sensor status. Correct trouble code as displayed. Replace module if defective.</b>

### 4.2-3 All Controls Inoperative From Base Control Console

1. Control Module CM1 display is broadcasting an error message.	<b>Check Control Module display screen and follow instructions to clear error.</b>
2. Loose or broken wire #03A to circuit breaker CB1 or circuit breaker is open	<b>Check continuity to circuit breaker. Test circuit breaker CB1. Replace if defective.</b>
3. Loose or broken wire #05 to Base Emergency Stop switch S28.	<b>Check continuity. Replace if defective.</b>
4. Open or defective Base Emergency Stop switch S28.	<b>Close switch by pulling knob out and check switch. Replace if defective.</b>
5. Loose or broken wire #05A from Base Emergency Stop switch S28 to Base Key switch S10	<b>Check continuity. Replace if defective.</b>
6. Open or defective Base Key Switch S10.	<b>Check switch. Check continuity between wire #05A and wire #08C on switch (when selected on Base or Platform) Check continuity between wire #05A and wire #07 on switch (when selected on Platform only) Check continuity between wire #05A and wire #10 on switch (when selected on Base only) Replace switch if no continuity when operating switch.</b>
7. Loose or broken wire #08C from Base Key switch S10 to Control Module CM1 pin #P3-1 (enable signal).	<b>Check continuity. Test for 24V Input voltage between wire #08C and wire #00. Use HMI Diagnostic menu to make sure input P3-1 signal is present. Replace if defective.</b>
8. Loose or broken wire #10 from Base Key switch S10 to Base Lift/Lower switch S2.	<b>Check continuity. Replace if defective.</b>
9. Loose or broken #10 wire from Base Key switch S10 to Control Module CM1 pin #P3-5 (Base signal)	<b>Check continuity. Test for 24V Input voltage between wire #10 and wire #00. Use HMI Diagnostic menu to make sure input P3-5 signal is present. Replace if defective.</b>
10. Open or defective Lift/Lower switch S2.	<b>Check switch. Check continuity between wire #10 and wire #14A on switch (when selected on Up) Check continuity between wire #10 and wire #13A on switch (when selected to Dn) Replace switch if no continuity when operating switch.</b>



11. Loose or broken #14A wire from Lift/Lower switch S2 to Control Module CM1 pin #P4-5 (Up signal)	<p><b>Check continuity. Test for 24V Input voltage between wire #14A and wire #00.</b></p> <p><b>Use HMI Diagnostic menu to make sure input P4-5 signal is present</b></p> <p><b>Replace if defective.</b></p>
12. Loose or broken #13A wire from Lift/Lower switch S2 to Control Module CM1 pin #P4-4 (Dn signal)	<p><b>Check continuity. Test for 24V Input voltage between wire #13A and wire #00.</b></p> <p><b>Use HMI Diagnostic menu to make sure input P4-4 signal is present.</b></p> <p><b>Replace if defective.</b></p>
13. External or internal fault detected by Control Module CM1	<p><b>Check Control Module display screen. Use Diagnostic Menu to see switch and sensor status.</b></p> <p><b>Correct trouble code as displayed. Replace module if defective.</b></p>

#### 4.2-4 No Up Function from Base Control Console

1. Control Module CM1 display is broadcasting an error message.	<p><b>Check Control Module display screen and follow instructions to clear error.</b></p>
2. Open or defective Lift/Lower switch S2.	<p><b>Check switch.</b></p> <p><b>Check continuity between wire #10 and wire #14A on switch. (Up Mode)</b></p> <p><b>Replace switch if no continuity when operating switch.</b></p>
3. Loose or broken wire #14A from Lift/Lower switch S2 to Control Module CM1 pin #P4-5 (Up signal).	<p><b>Check continuity. Test for 24V Input voltage between wire #14A and wire #00.</b></p> <p><b>Use HMI Diagnostic menu to make sure input P4-5 signal is present.</b></p> <p><b>Replace if defective.</b></p>
4. Loose or broken wire #14 from Control Module CM1 pin #P5-5 to Up valve coil 3H-14.	<p><b>Check continuity. Test for 24V Output voltage between wire #14 and wire #00.</b></p> <p><b>Use HMI Diagnostic menu to make sure output P5-5 signal is present.</b></p> <p><b>Replace if defective.</b></p>
5. Loose or broken wire #00 from Battery (-) to Up valve coil 3H-14.	<p><b>Check continuity. Replace if defective.</b></p>
6. Defective up valve coil 3H-14.	<p><b>Check continuity through coil. Replace if defective.</b></p>

7. Machine overloaded and Overload Lights PL-1 and PL-2 on Emergency Stop buttons flashing	<p>Check machine limits and reduce weight as required.</p> <p>Check Pressure Transducer PT1 and Angle Transducer AT1 functionality</p> <p>Check wire #60 from Control Module CM1 pin #P1-8 (overloaded signal).</p> <p>Test for 24V Output voltage between wire #60 and wire #00.</p> <p>Use HMI Diagnostic menu to make sure Output P1-8 signal is present (pulsed).</p>
8. Machine not level.	<p>Move machine and ONLY use on level surface.</p> <p>Check Control Module CM1 display.</p>
9. Check machine Tilt Procedure.	<p>Check Control Module CM1 display screen and perform Tilt Calibration Procedure ONLY if level has been checked and needs adjustment</p>
10. External or internal fault detected by Control Module CM1	<p>Check Control Module display screen. Use Diagnostic Menu to see switch and sensor status.</p> <p>Correct trouble code as displayed. Replace module if defective.</p>

#### 4.2-5 No Down Function from Base Control Console

1. Control Module CM1 display is broadcasting an error message.	<p>Check Control Module display screen and follow instructions to clear error.</p>
2. Open or defective Lift/Lower switch S2.	<p>Check switch.</p> <p>Check continuity between wire #10 and 13A on switch (Dn Mode)</p> <p>Replace switch if no continuity when operating switch.</p>
3. Loose or broken wire #13A from Lift/Lower switch S2 to Control Module CM1 pin #P4-4 (Dn signal).	<p>Check continuity. Test for 24V Input voltage between wire #13A and wire #00.</p> <p>Use HMI Diagnostic menu to make sure input P4-4 signal is present.</p> <p>Replace if defective.</p>
4. Loose or broken wire #13 from Control Module CM1 pin #P5-12 to holding valve coil 2H-13	<p>Check continuity. Test for 12V Output voltage between wire #13 and wire #00.</p> <p>Use HMI Diagnostic menu to make sure output P5-12 signal is present.</p> <p>Replace if defective.</p>
5. Loose or broken wire #00C from Holding valve coil 2H-13 to Control Module CM1 pin #P2-8	<p>Check continuity. Replace if defective.</p>
6. Defective Lift cylinder holding valve coil 2H-13	<p>Check continuity through coil. Replace if defective.</p>

7. Machine overloaded and Overload Lights PL-1 and PL-2 on Emergency Stop buttons flashing	<p>Check machine limits and reduce weight as required.</p> <p>Check Pressure Transducer PT1 and Angle Transducer AT1 functionality</p> <p>Check wire #60 from Control Module CM1 pin #P1-8 (overloaded signal)</p> <p>Test for 24V Output voltage between wire #60 and wire #00.</p> <p>Use HMI Diagnostic menu to make sure Output P1-8 signal is present (pulsed).</p>
8. External or internal fault detected by Control Module CM1	<p>Check Control Module display screen. Use Diagnostic Menu to see switch and sensor status.</p> <p>Correct trouble code as displayed. Replace module if defective.</p>

#### 4.2-6 No Emergency Down Function from Base Control Console\*



#### NOTE

\*circuit has redundant wiring and a multiple position (left - spring neutral center - right) Emergency Lowering toggle switch S51, which will allow function of lowering in either position from neutral center (see below scenarios)

1. Loose or broken wire #98 from Battery to Circuit Breaker CB2 or the circuit breaker is open.	Check continuity to circuit breaker. Test Circuit Breaker CB2. Replace if defective.
2. Loose or broken wire #98A from Circuit Breaker CB2 to Main Disconnect S1.	Check continuity. Replace if defective.
3. Main battery disconnect switch S1 open or defective.	Close switch. Check continuity. Replace if defective.

#### Scenario A:

- \*Emergency Lowering toggle switch S51 held in “up” position (as per electrical schematic)

▪ Loose or broken wire #98B from Main Disconnect S1 to Emergency Lowering switch S51.	Check continuity. Replace if defective.
---	---

▪ Loose or broken wire #05 from Circuit Breaker CB1 to Emergency Lowering switch S51.	Check continuity. Replace if defective.
---	---

▪ Open or defective Emergency Lowering switch S51.	<p>Check continuity between wire #98B and wire #00D on switch, and</p> <p>Check continuity between wire #05 and wire #13 on switch.</p> <p>Replace switch if no continuity on both of these two (2) contacts of switch.</p>
--	---

**Scenario B:**

- \*Emergency Lowering toggle switch S51 held in “down” position (as per electrical schematic)

- Loose or broken wire #00 from B- lug on Control Module CM1 to Emergency Lowering switch S51.

**Check continuity. Replace if defective.**

- Loose or broken wire #98B from Main Disconnect S1 to Emergency Lowering switch S51.

**Check continuity. Replace if defective.**

- Open or defective Emergency Lowering switch S51.

**Check continuity between wire #00 and wire #00D on switch, and**

**Check continuity between wire #98B and wire #13 on switch.**

**Replace switch if no continuity on both of these two (2) contacts of switch**

4. Loose or broken 2x wires #00D from Emergency Lowering switch S51 to Holding valve coil 2H-13.

**Check continuity. Replace if defective.**

5. Loose or broken 2x wires #13 from Emergency Lowering switch S51 to Holding valve coil 2H-13.

**Check continuity. Replace if defective.**

6. Loose or broken wire #00C from Control Module CM1 pin #P2-8 to Holding valve coil 2H-13.

**Check continuity. Replace if defective.**

7. Defective isolation Diodes D00C, D13-1 and/ or D13-2 for redundant circuits for Emergency Lowering.

**Check diodes and make sure connected securely. Replace if defective.**

8. Defective Lift cylinder Holding valve coil 2H-13.

**Check continuity through coil. Replace if defective.**

**4.2-7 All Controls Inoperative From Platform Control Console**

1. Control Module CM1 display is broadcasting an error message.

**Check Control Module display screen and follow instructions to clear error.**

2. Loose or broken wire #03A to Circuit Breaker CB1 or Circuit Breaker is open

**Check continuity to circuit breaker. Test circuit breaker CB1. Replace if defective.**

3. Loose or broken wire #05 to Base Emergency Stop switch S28.

**Check continuity. Replace if defective.**

4. Open or defective Base Emergency Stop switch S28.

**Close switch by pulling knob out and check switch.**

**Check continuity between wire #05 and wire #05A.**

**Replace switch if defective.**

5. Incorrect selection of Base Key Switch S10.

**Check switch is on Platform selection**

**Operate and check switch.**

6. Open or defective Base Key Switch S10.

**Check continuity between wire #05A and wire #07 on switch (Platform Mode selected)**

**Replace if defective when operating switch.**

7. Loose or broken wire #08C from Base Key switch S10 to Control Module CM1 pin #3-1 (enable signal).	<p><b>Check continuity. Test for 24V Input voltage between wire #08C and wire #00.</b></p> <p><b>Use HMI Diagnostic menu to make sure input P3-1 signal is present.</b></p> <p><b>Replace if defective.</b></p>
8. Loose or broken wire #07 from Base Key switch S10 to platform Emergency Stop switch S4.	<p><b>Check continuity. Replace if defective.</b></p>
9. Open or defective platform Emergency Stop switch S4.	<p><b>Close switch by pulling knob out and check switch.</b></p> <p><b>Check continuity between wire #07 and wire #08.</b></p> <p><b>Replace switch if defective.</b></p>
10. Loose or broken wire #08 from platform Emergency Stop switch S4 to Control module CM1 pin #P3-2. (platform signal)	<p><b>Check continuity. Test for 24V Input voltage between wire #08 and wire #00.</b></p> <p><b>Use HMI Diagnostic menu to make sure input P3-2 signal is present.</b></p> <p><b>Replace if defective.</b></p>
11. Loose or broken wire #08 from platform Emergency Stop switch S4 to Lift/Off/Drive switch S3	<p><b>Check continuity. Replace if defective.</b></p>
12. Open or defective Lift/Off/Drive switch S3.	<p><b>Check switch.</b></p> <p><b>Check continuity between wire #08 and wire #12 (Drive Mode selected)</b></p> <p><b>Check continuity between wire #08 and wire #09 (Lift Mode selected)</b></p> <p><b>Replace if no continuity when operating switch.</b></p>
13. Loose or broken wire #12 from Lift/Off/Drive switch S3 to Control Module CM1 pin #P3-6. (drive signal)	<p><b>Check continuity. Test for 24V Input voltage between wire #12 and wire #00.</b></p> <p><b>Use HMI Diagnostic menu to make sure input P3-6 signal is present.</b></p> <p><b>Replace if defective.</b></p>
14. Loose or broken wire #09 from Lift/Off/Drive switch S3 to Control Module CM1 pin #P3-7. (lift signal).	<p><b>Check continuity. Test for 24V Input voltage between wire #09 and wire #00.</b></p> <p><b>Use HMI Diagnostic menu to make sure input P3-7 signal is present.</b></p> <p><b>Replace if defective.</b></p>
15. Loose or broken wire #08 from platform Emergency Stop switch S4 to Joystick S7.	<p><b>Check continuity. Replace if defective.</b></p>
16. Defective Joystick switches S7-6 Enable, S7-2 steer right and S7-3 steer left.	<p><b>Check switches.</b></p> <p><b>Check continuity between wire #08 and wire #08A (enable signal)</b></p> <p><b>Check continuity between wire #08 and wire #23 (steer right signal)</b></p> <p><b>Check continuity between wire #08 and wire #24 (steer left signal)</b></p> <p><b>Replace Joystick if no continuity when operating individual switches.</b></p>

<p>17. Loose or broken wire #08A from Joystick Enable switch S7-6 to Control Module CM1 pin #P3-12. (enable signal)</p>	<p><b>Check continuity. Test for 24V Input voltage between wire #08A and wire #00.</b></p> <p><b>Use HMI Diagnostic menu to make sure input P3-12 signal is present.</b></p> <p><b>Replace if defective.</b></p>
<p>18. Loose or broken wire #23 from Joystick S7-2 to Control Module CM1 pin #P3-8. (steer right signal)</p>	<p><b>Check continuity. Test for 24V Input voltage between wire #23 and wire #00.</b></p> <p><b>Use HMI Diagnostic menu to make sure input P3-8 signal is present.</b></p> <p><b>Replace if defective.</b></p>
<p>19. Loose or broken wire #24 from Joystick S7-3 to Control Module CM1 pin #P3-9. (steer left signal)</p>	<p><b>Check continuity. Test for 24V Input voltage between wire #24 and wire #00.</b></p> <p><b>Use HMI Diagnostic menu to make sure input P3-9 signal is present.</b></p> <p><b>Replace if defective.</b></p>
<p>20. Defective Joystick S7 PCB.</p>	<p><b>Check joystick.</b></p> <p><b>Replace joystick if defective.</b></p>
<p>21. Loose or broken wire #00B from Control Module CM1 pin #P1-3 to joystick S7 (0V reference signal)</p>	<p><b>Check continuity. Replace if defective.</b></p>
<p>22. Loose or broken wire #59 from Joystick S7 to Control Module CM1 pin #P1-2. (analog output signal)</p>	<p><b>Check continuity. Use HMI Diagnostic menu to make sure proportional input P1-2 signal is present.</b></p> <p><b>Replace if defective.</b></p>
<p>23. Loose or broken wire #08B from Joystick S7 to Control Module CM1 pin #P1-1. (5V input signal)</p>	<p><b>Check continuity. Replace if defective.</b></p>
<p>24. External or internal fault detected by Control Module CM1</p>	<p><b>Check Control Module display screen. Use Diagnostic Menu to see switch and sensor status.</b></p> <p><b>Correct trouble code as displayed. Replace module if defective.</b></p>

### 4.2-8 No Up Function from Platform Controls (ANSI/CSA, CE, and AS)

1. Control Module CM1 display is broadcasting an error message.	<b>Check Control Module display screen and follow instructions to clear error.</b>
2. Loose or broken wire #09 from Lift/Off/Drive switch S3 to Control Module CM1 pin #P3-7.	<b>Check continuity. Test for 24V Input voltage between wire #09 and wire #00. Use HMI Diagnostic menu to make sure input P3-7 signal is present. Replace if defective.</b>
3. Lift//Off/Drive switch S3 is set to an incorrect mode.	<b>Select Lift. Check switch. Replace if defective.</b>
4. Loose or broken wire #59 from Joystick S7 to Control Module CM1 pin #P1-2.	<b>Check continuity. Use HMI Diagnostic menu to make sure proportional input P1-2 signal is present. Replace if defective.</b>
5. Loose or broken wire #14 from Control module CM1 pin #P5-5 to Up valve coil 3H-14.	<b>Check continuity. Test for 24V Output voltage between wire #14 and wire #00. Use HMI Diagnostic menu to make sure output P5-5 signal is present. Replace if defective.</b>
6. Loose or broken wire #00 from Battery (-) to Up valve coil 3H-14.	<b>Check continuity. Replace if defective.</b>
7. Defective up valve coil 3H-14.	<b>Check continuity through coil. Replace if defective.</b>
8. Machine overloaded and Overload Lights PL-1 and PL-2 on Emergency Stop buttons flashing.	<b>Check machine limits and reduce weight as required. Check Pressure Transducer PT1 and Angle Transducer AT1 functionality. Check wire #60 from Control Module CM1 pin #P1-8 (overloaded signal). Test for 24V Output voltage between wire #60 and wire #00. Use HMI Diagnostic menu to make sure Output P1-8 signal is present (pulsed).</b>
9. Machine not level.	<b>Move machine and ONLY use on level surface. Check Control Module CM1 display.</b>
10. Check machine Tilt Procedure.	<b>Check Control Module CM1 display screen and perform Tilt Calibration Procedure ONLY if level has been checked and needs adjustment.</b>
11. External or internal fault detected by Control Module CM1.	<b>Check Control Module display screen. Use Diagnostic Menu to see switch and sensor status. Correct trouble code as displayed. Replace module if defective.</b>



### 4.2-9 No Up Function from Platform Controls (KC)

1. Control Module CM1 display is broadcasting an error message.	<b>Check Control Module display screen and follow instructions to clear error.</b>
2. Loose or broken wire #09 from Lift/Off/Drive switch S3 to Control Module CM1 pin #P3-7.	<b>Check continuity. Test for 24V Input voltage between wire #09 and wire #00. Use HMI Diagnostic menu to make sure input P3-7 signal is present. Replace if defective.</b>
3. Lift//Off/Drive switch S3 is set to an incorrect mode.	<b>Select Lift. Check switch. Replace if defective.</b>
4. Loose or broken wire #08C from Base Key Switch S10 to Anti-Overriding Limit switch LS7B N.C contact.	<b>Check continuity. Replace if defective.</b>
5. Open or defective Anti-Overriding Limit switch LS7B	<b>Check switch. Check continuity between wire #08C and wire #52A. N.C. contact on Anti-Overriding Limit switch LS7B. Replace Limit switch if defective.</b>
6. Loose or broken wire #52A from Anti-Overriding Limit switch LS7B to Anti-Overriding Limit switch LS7C (if equipped).	<b>Check continuity. Replace if defective.</b>
7. Open or defective Anti-Overriding Limit switch LS7C (if equipped).	<b>Check switch. Check continuity between wire #52A and wire #52B N.C. contact on Anti-Overriding Limit switch LS7C Replace limit switch if defective.</b>
8. Loose or broken wire #52B from Anti-Overriding Limit switch LS7C to Anti-Overriding Limit switch LS7D (if equipped).	<b>Check continuity. Replace if defective.</b>
9. Open or defective Anti-Overriding Limit switch LS7D (if equipped).	<b>Check switch. Check continuity between wire #52B and wire #52A. N.C. contact on Anti-Overriding Limit switch LS7D. Replace Limit switch if defective.</b>
10. Loose or broken wire #52A from Anti-Overriding Limit switch LS7D to Anti-Overriding Limit switch LS7A.	<b>Check continuity. Replace if defective.</b>
11. Open or defective Anti-Overriding Limit switch LS7A.	<b>Check switch. Check continuity between wire #52A and wire #51. N.C. contact on Anti-Overriding Limit switch LS7A Replace limit switch if defective.</b>



12. Loose or broken wire #51 from Anti-Overriding Limit switch LS7A to Control Module CM1 pin #P3-11.	<p>Check continuity to make sure input is high to signal limit switches are not jammed open.</p> <p>Test for 24V Output voltage between wire #51 and wire #00.</p> <p>Use HMI Diagnostic menu to make sure output P3-11 signal is present.</p> <p>Replace if defective.</p>
13. Closed or defective Anti-Overriding Limit switches LS7A, LS7C, LS7D, and/or LS7B N.O contacts.	<p>Check switches.</p> <p>Check continuity between wire #08C and wire #51A. N.O. contacts on all Limit switches for input to Control Module CM1 pin #P3-10 signaling one or more of the limit switches are jammed closed.</p> <p>Test for 24V Output voltage between wire #51A and wire #00.</p> <p>Use HMI Diagnostic menu to make sure output P3-11 signal is NOT present.</p> <p>Replace Limit switch or switches that are defective.</p>
14. Loose or broken wire #59 from Joystick S7 to Control Module CM1 pin #P1-2.	<p>Check continuity. Use HMI Diagnostic menu to make sure proportional input P1-2 signal is present.</p> <p>Replace if defective.</p>
15. Loose or broken wire #14 from Control module CM1 pin #P5-5 to Up valve coil 3H-14.	<p>Check continuity. Test for 24V Output voltage between wire #14 and wire #00.</p> <p>Use HMI Diagnostic menu to make sure output P5-5 signal is present.</p> <p>Replace if defective.</p>
16. Loose or broken wire #00 from Battery (-) to Up valve coil 3H-14.	<p>Check continuity. Replace if defective.</p>
17. Defective up valve coil 3H-14.	<p>Check continuity through coil. Replace if defective.</p>
18. Machine overloaded and Overload Lights PL-1 and PL-2 on Emergency Stop buttons flashing.	<p>Check machine limits and reduce weight as required.</p> <p>Check Pressure Transducer PT1 and Angle Transducer AT1 functionality</p> <p>Check wire #60 from Control Module CM1 pin #P1-8 (overloaded signal)</p> <p>Test for 24V Output voltage between wire #60 and wire #00.</p> <p>Use HMI Diagnostic menu to make sure Output P1-8 signal is present (pulsed).</p>
19. Machine not level.	<p>Move machine and ONLY use on level surface.</p> <p>Check Control module CM1 display.</p>
20. Check machine Tilt Procedure.	<p>Check Control Module CM1 display screen and perform Tilt Calibration Procedure ONLY if level has been checked and needs adjustment.</p>

21. External or internal fault detected by Control Module CM1.

**Check Control Module display screen. Use Diagnostic Menu to see switch and sensor status. Correct trouble code as displayed. Replace module if defective.**

#### 4.2-10 No Down Function from Platform Controls

1. Control Module CM1 display is broadcasting an error message.

**Check Control Module display screen and follow instructions to clear error.**

2. Loose or broken wire #09 from Lift/Off/Drive switch S3 to Control Module CM1 pin #P3-7.

**Check continuity. Test for 24V Input voltage between wire #09 and wire #00.**

**Use HMI Diagnostic menu to make sure input P3-7 signal is present.**

**Replace if defective.**

3. Lift//Off/Drive switch S3 is set in an incorrect mode or is defective.

**Select Lift. Check switch. Replace if defective.**

4. Loose or broken wire #59 from Joystick S7 to Control Module CM1 pin #P1-2.

**Check continuity. Use HMI Diagnostic menu to make sure proportional input P1-2 signal is present.**

**Replace if defective.**

5. Loose or broken wire #13 from Control Module CM1 pin #P5-12 to Holding valve coil 2H-13.

**Check continuity. Test for 24V Output voltage between wire #13 and wire #00.**

**Use HMI Diagnostic menu to make sure output P5-12 signal is present.**

**Replace if defective.**

6. Loose or broken wire #00C from Holding valve coil 2H-13 to Control Module CM1 pin #P2-8.

**Check continuity. Replace if defective.**

7. Defective Holding valve coil 2H-13.

**Check continuity through coil. Replace if defective.**

8. Machine overloaded and Overload Lights PL-1 and PL-2 on Emergency Stop buttons flashing.

**Check machine limits and reduce weight as required.**

**Check Pressure Transducer PT1 and Angle Transducer AT1 functionality.**

**Check wire #60 from Control Module CM1 pin #P1-8 (overloaded signal)**

**Test for 24V Output voltage between wire #60 and wire #00.**

**Use HMI Diagnostic menu to make sure Output P1-8 signal is present (pulsed).**

9. External or internal fault detected by Control Module CM1.

**Check Control Module display screen. Use Diagnostic Menu to see switch and sensor status.**

**Correct trouble code as displayed. Replace module if defective.**

### 4.2-11 Right Steer Inoperative

1. Control Module CM1 display is broadcasting an error message.	<b>Check Control Module display screen and follow instructions to clear error.</b>
2. Lift//Off/Drive switch S3 is set to an incorrect mode.	<b>Select Drive. Check switch. Replace if defective.</b>
3. Defective Right Steer switch S7-2.	<b>Check switch. Check continuity between wire #08 and wire #23 on switch. (Right Steer signal) Replace switch if no continuity when operating switch.</b>
4. Loose or broken wire #23 from Right Steer switch S7-2 to Control Module CM1 pin #P3-8.	<b>Check continuity. Test for 24V Input voltage between wire #23 and wire #00. Use HMI Diagnostic menu to make sure input P3-8 signal is present. Replace if defective.</b>
5. Loose or broken wire #23A from Control Module CM1 pin #P5-8 to Right Steer valve coil 4H-23A.	<b>Check continuity. Test for 24V Output voltage between wire #23A and wire #00. Use HMI Diagnostic menu to make sure output P5-8 signal is present. Replace if defective.</b>
6. Loose or broken wire #00 from Battery (-) to Right Steer valve coil 4H-23A.	<b>Check continuity. Replace if defective.</b>
7. Defective Right Steer valve coil 4H-23A.	<b>Check continuity through coil. Replace if defective.</b>
8. External or internal fault detected by Control Module CM1.	<b>Check Control Module display screen. Use Diagnostic Menu to see switch and sensor status. Correct trouble code as displayed. Replace module if defective.</b>

### 4.2-12 Left Steer Inoperative

1. Control Module CM1 display is broadcasting an error message.	<b>Check Control Module display screen and follow instructions to clear error.</b>
2. Lift//Off/Drive switch S3 is set to an incorrect mode.	<b>Select Drive. Check switch. Replace if defective.</b>
3. Defective Left Steer switch S7-3.	<b>Check switch. Check continuity between wire #08 and wire #24 on switch (Left Steer signal). Replace switch if no continuity when operating switch.</b>

4. Loose or broken wire #24 from Left Steer switch S7-3 pin to Control Module CM1 pin #P3-9.	<p><b>Check continuity. Test for 24V Input voltage between wire #24 and wire #00.</b></p> <p><b>Use HMI Diagnostic menu to make sure input P3-9 signal is present.</b></p> <p><b>Replace if defective.</b></p>
5. Loose or broken wire #24A from Control Module CM1 pin #P5-6 to Left Steer valve coil 4H-24A.	<p><b>Check continuity. Test for 24V Output voltage between wire #24A and wire #00.</b></p> <p><b>Use HMI Diagnostic menu to make sure output P5-6 signal is present.</b></p> <p><b>Replace if defective.</b></p>
6. Loose or broken wire #00 from Battery (-) to Left Steer valve coil 4H-24A.	<p><b>Check continuity. Replace if defective.</b></p>
7. Defective Left Steer valve coil 4H-24A.	<p><b>Check continuity through coil. Replace if defective.</b></p>
8. External or internal fault detected by Control Module CM1	<p><b>Check Control Module display screen. Use Diagnostic Menu to see switch and sensor status.</b></p> <p><b>Correct trouble code as displayed. Replace module if defective.</b></p>

#### 4.2-13 Forward Drive Function Inoperative

1. Control Module CM1 display is broadcasting an error message.	<p><b>Check Control Module display screen and follow instructions to clear error.</b></p>
2. Loose or broken wire #12 from Lift/Off/Drive switch S3 to Control Module CM1 pin #P3-6.	<p><b>Check continuity. Test for 24V Input voltage between wire #12 and wire #00.</b></p> <p><b>Use HMI Diagnostic menu to make sure input P3-6 signal is present.</b></p> <p><b>Replace if defective.</b></p>
3. Lift//Off/Drive switch S3 is set in an incorrect mode or is defective.	<p><b>Select Drive. Check switch. Replace if defective.</b></p>
4. Loose or broken wire #59 from Joystick S7 to Control Module CM1 pin #P1-2.	<p><b>Check continuity. Use HMI Diagnostic menu to make sure proportional input P1-2 signal is present.</b></p> <p><b>Replace if defective.</b></p>
5. Defective Joystick Enable switch S7-6.	<p><b>Check switch.</b></p> <p><b>Check continuity between wire #08 and wire #08A on switch.</b></p> <p><b>Replace Joystick if no continuity when operating switch.</b></p>
6. Defective Joystick S7.	<p><b>Check joystick. Replace if defective.</b></p>
7. Loose or broken wire #00B from Control Module CM1 pin #P1-3 to Joystick S7 (0V reference)	<p><b>Check continuity. Replace if defective.</b></p>

8. Loose or broken wire #59 from Joystick S7 to Control Module CM1 pin #P1-2. (analog output signal)	<b>Check continuity. Use HMI Diagnostic menu to make sure proportional input P1-2 signal is present. Replace if defective.</b>
9. Loose or broken wire #08B from Control Module CM1 pin #P1-1 to Joystick S7. (5V supply)	<b>Check continuity. Replace if defective.</b>
10. Loose or broken wire #16 from Control Module CM1 pin #P5-2 to Forward Drive valve coil 4H-16.	<b>Check continuity. Test for 24V Output voltage between wire #16 and wire #00. Use HMI Diagnostic menu to make sure output P5-2 signal is present. Replace if defective.</b>
11. Loose or broken wire #00 from Battery (-) to Forward Drive valve coil 4H-16	<b>Check continuity. Replace if defective.</b>
12. Loose or broken wire #17 from Control Module CM1 pin #P5-4 to Brake valve coil 3H-17.	<b>Check continuity. Test for 24V Output voltage between wire #17 and wire #00. Use HMI Diagnostic menu to make sure output P5-4 signal is present. Replace if defective.</b>
13. Loose or broken wire #00 from Battery (-) to Brake valve coil 3H-17	<b>Check continuity. Replace if defective.</b>
14. Defective Forward Drive valve coil 4H-16.	<b>Check continuity through coil. Replace if defective.</b>
15. Defective Brake valve coil 3H-17.	<b>Check continuity through coil. Replace if defective.</b>
16. External or internal fault detected by Control Module CM1.	<b>Check Control Module display screen. Use Diagnostic Menu to see switch and sensor status. Correct trouble code as displayed. Replace module if defective.</b>

#### 4.2-14 Reverse Drive Function Inoperative

1. Control Module CM1 display is broadcasting an error message.	<b>Check Control Module display screen and follow instructions to clear error.</b>
2. Loose or broken wire #12 from Lift/Off/Drive switch S3 to Control Module CM1 pin #P3-6.	<b>Check continuity. Test for 24V Input voltage between wire #12 and wire #00. Use HMI Diagnostic menu to make sure input P3-6 signal is present. Replace if defective.</b>
3. Lift//Off/Drive switch S3 is set in an incorrect mode or is defective.	<b>Select Drive. Check switch. Replace if defective.</b>
4. Loose or broken wire #59 from Joystick S7 to Control Module CM1 pin #P1-2.	<b>Check continuity. Use HMI Diagnostic menu to make sure proportional input P1-2 signal is present. Replace if defective.</b>

5. Defective Joystick Enable switch S7-6.	<p>Check switch.  Check continuity between wire #08 and wire #08A on switch.  Replace Joystick if no continuity when operating switch.</p>
6. Defective joystick S7.	Check joystick. Replace if defective.
7. Loose or broken wire #00B from Control Module CM1 pin #P1-3 to Joystick S7 (0V reference)	Check continuity. Replace if defective.
8. Loose or broken wire #59 from Joystick S7 to Control Module CM1 pin #P1-2. (analog output signal)	<p>Check continuity. Use HMI Diagnostic menu to make sure proportional input P1-2 signal is present.  Replace if defective.</p>
9. Loose or broken wire #08B from Control Module CM1 pin #P1-1 to Joystick S7. (5V supply)	Check continuity. Replace if defective.
10. Loose or broken wire #15 from Control Module CM1 pin #P5-3 to Reverse Drive valve coil 4H-15.	<p>Check continuity. Test for 24V Output voltage between wire #15 and wire #00.  Use HMI Diagnostic menu to make sure output P5-3 signal is present.  Replace if defective.</p>
11. Loose or broken wire #00 from Battery (-) to Reverse Drive valve coil 4H-15	Check continuity. Replace if defective.
12. Loose or broken wire #17 from Control Module CM1 pin #P5-4 to Brake valve coil 3H-17.	<p>Check continuity. Test for 24V Output voltage between wire #17 and wire #00.  Use HMI Diagnostic menu to make sure output P5-4 signal is present.  Replace if defective.</p>
13. Loose or broken wire #00 from Battery (-) to Brake valve coil 3H-17	Check continuity. Replace if defective.
14. Defective Reverse Drive valve coil 4H-15.	Check continuity through coil. Replace if defective.
15. Defective Brake valve coil 3H-17.	Check continuity through coil. Replace if defective.
16. External or internal fault detected by Control Module CM1.	<p>Check Control Module display screen. Use Diagnostic Menu to see switch and sensor status.  Correct trouble code as displayed. Replace module if defective.</p>

### 4.2-15 No Drive or Steer when Platform Elevated

1. Control Module CM1 display is broadcasting an error message.	<b>Check Control Module display screen and follow instructions to clear error.</b>
2. Pothole protection bars not fully lowered.	<b>Clear obstructions. Repair as needed.</b>
3. Loose or broken wire #910 from Control Module CM1 pin #P2-7 to pothole protection limit switch LS1	<b>Check continuity. Test for 24V Output voltage between wire #910 and wire #902 at P6-4. Use HMI Diagnostic menu to make sure output P2-7 supply is present. Replace if defective.</b>
4. Defective pothole protection limit switch LS1.	<b>Check switch. Check continuity between wire #910 and wire #72 at switch. Replace if no continuity when operating switch.</b>
5. Loose or broken wire #72 from pothole protection limit switch LS1 to pothole protection limit switch LS2.	<b>Check continuity. Replace if defective.</b>
6. Defective pothole protection limit switch LS2	<b>Check switch. Check continuity between wire #72 and wire #71. Replace if no continuity when operating switch.</b>
7. Loose or broken wire #71 from pothole protection limit switch LS2 to Control Module CM1 pin #P4-7.	<b>Check continuity. Test for 24V Input voltage between wire #71 and wire #00. Use HMI Diagnostic menu to make sure input P4-7 signal is present. Replace if defective.</b>
8. External or internal fault detected by Control Module CM1	<b>Check Control Module display screen. Use Diagnostic Menu to see switch and sensor status. Correct trouble code as displayed. Replace module if defective.</b>

### 4.2-16 Pressure Transducer PT1 Inoperative

1. Control Module CM1 display is broadcasting an error message.	<b>Check Control Module display screen and follow instructions to clear error.</b>
2. Loose or broken wire #910 from Control Module pin #P2-7 to B+(pin1) on Pressure Transducer PT1.	<b>Check continuity. Test for 24V Output voltage between wire #910 and wire #902 at P6-4. Use HMI Diagnostic menu to make sure output P2-7 supply is present. Replace if defective.</b>
3. Loose or broken wire #902 from Control Module pin #P2-3 to GND (pin3) on Pressure Transducer PT1.	<b>Check continuity. Replace if defective.</b>



4. Loose or broken wire #60A from Control Module pin #P2-4 to SIG (pin2) on Pressure Transducer PT1	<b>Check continuity. Use HMI Diagnostic menu to make sure proportional input P2-4 signal is present. Replace if defective.</b>
5. Defective Pressure Transducer PT1.	<b>Check operation. Replace if defective.</b>
6. External or internal fault detected by Control Module CM1	<b>Check Control Module display screen. Use Diagnostic Menu to see switch and sensor status. Correct trouble code as displayed. Replace module if defective.</b>

#### 4.2-17 Angle Transducer AT1 Inoperative

1. Control Module CM1 display is broadcasting an error message.	<b>Check Control Module display screen and follow instructions to clear error.</b>
2. Loose or broken wire #910 from Control Module CM1 pin #2-7 to B+ (pin 1) on Angle Transducer AT1.	<b>Check continuity. Test for 24V Output voltage between wire #910 and wire #902 at P6-4. Use HMI Diagnostic menu to make sure output P2-7 supply is present. Replace if defective.</b>
3. Loose or broken wire #902 from Control Module pin #P2-3 to GND (pin2) on Angle Transducer AT1 .	<b>Check continuity. Replace if defective.</b>
4. Loose or broken wire #28 from Control Module pin #P2-2 to SIG (pin3) on Angle Transducer AT1.	<b>Check continuity. Use HMI Diagnostic menu to make sure proportional input P2-2 signal is present. Replace if defective.</b>
5. Loose or broken wire #28A from Control Module pin #P2-5 to SIG (pin4) on Angle Transducer AT1.	<b>Check continuity. Use HMI Diagnostic menu to make sure proportional input P2-5 signal is present. Replace if defective.</b>
6. Defective Angle Transducer AT1.	<b>Check operation. Replace if defective</b>
7. External or internal fault detected by Control Module CM1.	<b>Check Control Module display screen. Use Diagnostic Menu to see switch and sensor status. Correct trouble code as displayed. Replace module if defective.</b>



## 4.3 Hydraulic System

### 4.3-1 All Functions Inoperative

1. Electric Motor DCM1 not engaged.	Refer to electrical troubleshooting.
2. Pump P1 defective.	Check system pressures and Pump P1 functionality. Replace if defective.

### 4.3-2 All System Sluggish

1. System Relief Valve R1 defective or not adjusted properly.	Adjust valve. Replace if defective.
2. Hydraulic pump P1 worn.	Check system pressure and flow from Pump P1. Replace if defective.

### 4.3-3 Platform Drifts Down

1. Defective or leaking Lift Cylinder(s) seals at the gland.	Replace if damaged. Note: There are no piston seals, just wear rings.
2. Combination of stuck or defective Holding valve 2H-13.	Check valves. Replace if defective.

### 4.3-4 Platform Lifts Slowly

1. Defective Lift valve 3H-14.	Check valve. Replace if defective.
2. Lift Relief valve R2 is set incorrectly.	Check pressures. Replace if defective.
3. Defective Holding valve 2H-13.	Check Holding valve 2H-13. Replace if defective.
4. Defective or plugged Lift Orifice O3.	Clean Orifice. Replace if defective.

### 4.3-5 Platform Does Not Lift

1. Defective Lift valve 3H-14.	Check valve. Replace if defective.
2. Hydraulic oil level too low.	Fully lower the platform. Fill hydraulic tank until fluid is at or slightly above the top mark on the sight glass.
3. Machine overloaded and Overload Lights PL-1 and PL-2 on Emergency Stop buttons flashing.	Check machine limits and reduce weight as required. Refer to Electrical troubleshooting.
4. Defective or plugged Lift Orifice O3.	Clean Orifice. Replace if defective.
5. Leaking or defective Lift cylinder C1.	Check cylinder(s). Replace if defective.

### 4.3-6 Platform Will Not Lower

1. Defective Lift valve 3H-14.	<b>Check valve. Replace if defective.</b>
2. Defective Holding valve 2H-13.	<b>Clean valve. Replace if defective.</b>
3. Defective or plugged Lift Orifice O3.	<b>Clean Orifice. Replace if defective.</b>
4. Machine overloaded and Overload Lights PL-1 and PL-2 on Emergency Stop buttons flashing	<b>Check machine limits and reduce weight as required. Refer to Electrical troubleshooting.</b>

### 4.3-7 Platform Drives Slow

1. Free-wheeling valve V2 open or defective.	<b>Close valve. Replace if defective.</b>
2. Defective or plugged Drive Orifice O4.	<b>Clean Orifice. Replace if defective.</b>
3. Defective Counterbalance valve CB1.	<b>Check valve. Replace if defective.</b>
4. Drive Motors M1 and/or M2 defective.	<b>Check motors. Replace if defective.</b>

### 4.3-8 Platform Will Not Drive in Forward or Reverse

1. Free-Wheeling valve V2 is open or defective.	<b>Close valve. Replace if defective.</b>
2. Brakes are not released.	<b>Check brakes. Replace if defective.</b>
3. Forward Drive valve 4H-16 or Reverse Drive valve 4H-15 is defective.	<b>Check valves. Replace if defective.</b>
4. Defective or plugged Drive Orifice O4.	<b>Clean Orifice. Replace if defective.</b>
5. Defective Counter Balance valve CB1	<b>Check valve. Replace if defective.</b>
6. Drive Motors M1 and/or M2 defective.	<b>Check motors. Replace if defective.</b>

### 4.3-9 Brake(s) will not Release (Pin Brakes)

1. Brake Release valve 3H-17 is defective.	<b>Check valve. Replace if defective.</b>
2. Defective or plugged Brake Orifice O5.	<b>Check Orifice. Replace if defective.</b>
3. Leaking or defective Brake Cylinder.	<b>Check cylinder. Replace or repair if defective.</b>

### 4.3-10 Brake(s) will not Release (Wet Brakes)

1. Brake Release valve 3H-17 is defective.	<b>Check valve. Replace if defective.</b>
2. Brake Override valve V1 is defective.	<b>Check valve. Replace if defective.</b>
3. Defective internal brake piston seals.	<b>Check brake pack will maintain pressure. If pressure is not maintained replace seals.</b>
4. Defective Brakes BR1 and/or BR2.	<b>Inspect wheel assembly. Repair and replace as necessary.</b>

### 4.3-11 MEWP will not hold on a Grade (Wet Brakes)

1. Worn or damaged brake(s).	<b>Inspect brake discs for wear. Replace if worn or damaged.</b>
2. Broken or damaged brake compression springs.	<b>Check springs. Replace if defective.</b>
3. Defective Brakes BR1 and/or BR2.	<b>Inspect wheel assembly. Repair and replace as necessary.</b>

### 4.3-12 Platform does not Steer

1. Right Steer valve 4H-23A and/or Left Steer valve 4H-24A is defective.	<b>Check valves. Replace if defective.</b>
2. Steer cylinder C2 seal leaking.	<b>Rebuild cylinder. Replace if damaged.</b>
3. Steering cylinder Orifice O1 and/or O2 is plugged.	<b>Clean orifice. Replace if damaged.</b>
4. Mechanical binding in kingpins.	<b>Check for binding. Repair as needed.</b>

---

# Section 5 – Procedures

## 5.1 General

The following information is provided to assist you in the use and application of servicing and maintenance procedures contained in this chapter.





### NOTE

*The illustrations in this manual are for instructional purposes only. The models and components shown may appear somewhat different from those on your actual MEWP.*

### 5.1-1 Safety and Workmanship

Your safety, and that of others, is the first consideration when engaging in the maintenance of equipment. Always be conscious of weight. Never attempt to move heavy parts without the aid of a mechanical device. Do not allow heavy objects to rest in an unstable position. When raising a portion of the equipment, make sure that adequate support is provided.

Unless specifically noted otherwise, before beginning any procedure:

1. Park the mobile elevating work platform (MEWP) on a firm, level surface.
2. Fully lower the machine.
3. Push in the “” emergency stop buttons on the platform control console and the base control console.
4. Turn the off/platform/base key switch to the “” off position. Remove the key.
5. Turn the main power disconnect switch to the “” off position.

After completing any procedure which involves modifying, adjusting, or replacing any hydraulic or electrical components, perform all of the function tests given in your unit's operation Manual.

---

### WARNING

**Fall Hazard. Use the three points of contact principle when you use the MEWP to enter or exit the platform. If you do not obey, there is a risk of death or serious injury.**

---

---

### WARNING

**DO NOT operate any control on the platform control console without proper fall protection secured to the designated location in the platform. Failure to avoid this hazard could result in death or serious injury!**

---

---

### WARNING

**Make sure there are no people or obstructions in the test area, and there is sufficient space for the scissor and drive functions required for the given procedures.**

---

## 5.2 Platform

### 5.2-1 Single Axis Joystick

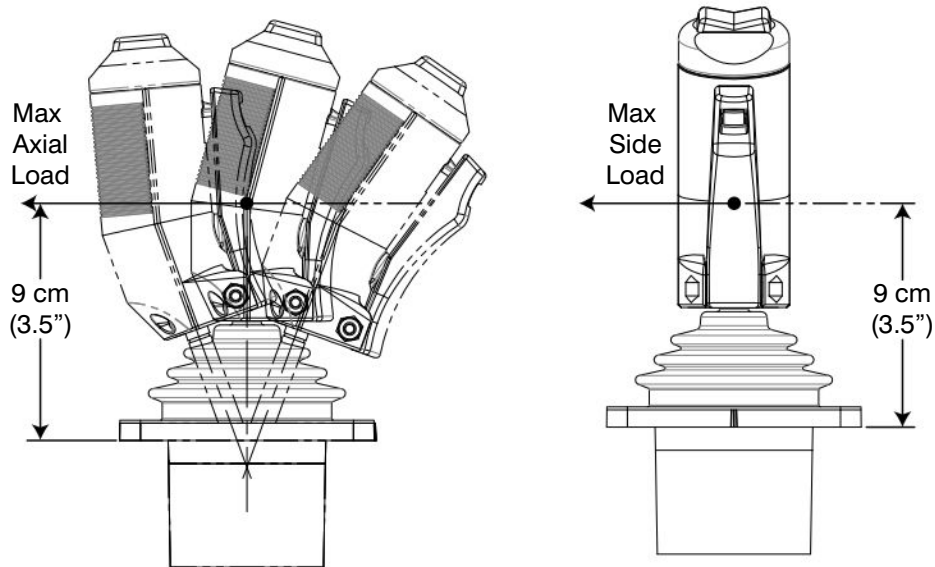

#### Joystick Switch Wiring

WIRE CHART		
COLOR	FUNCTION	PIN #
WHITE/RED	STEER LEFT	1
NONE	N/A	2
WHITE	STEER RIGHT	3
WHITE/BLUE	ENABLE TRIGGER	4
WHITE/BLACK	HANDLE COM (+24V)	5
GRAY	GROUND	6
BLUE	PROPORTIONAL OUTPUT	7
YELLOW	POWER (+5V)	8

#### Joystick Specifications

Input Voltage	5.0V
Center	2.40V to 2.60V
C DIR Full	0.40V to 0.60V
D DIR Full	4.40V to 4.60V
*Side Load Max	15.8 Nm (140 ft-lb)
*Axial Load Max	15.8 Nm (140 ft-lb)
Operating Temperature	-40°C to 85°C
Storage Temperature	-40°C to 85°C
IP Rating	IP 57

\*Load applied at dimensions shown on the diagram

#### Joystick Output Graph

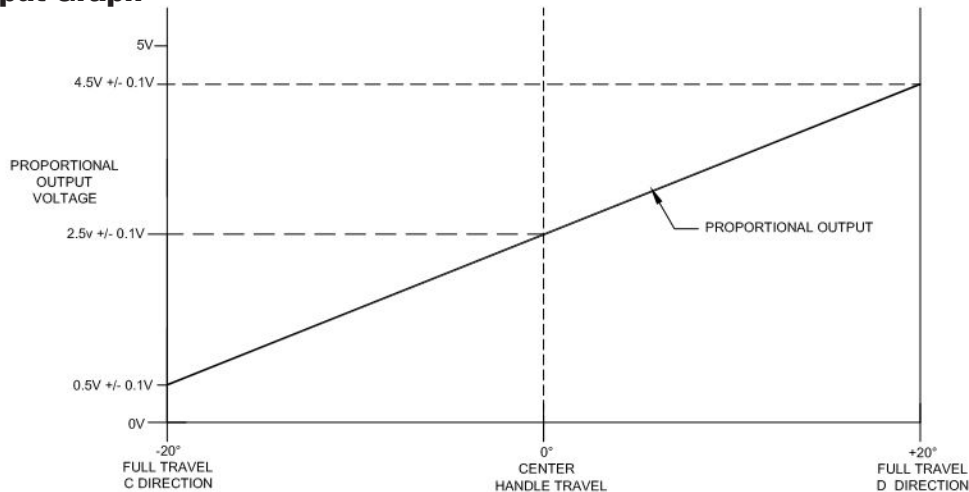

### 5.2-2 Gate Spring Hinge Adjustment

1. The tension of the spring hinges should be such that when the gate is opened halfway and released, it will close fully and latch.
2. To adjust the tension of the spring hinges, first remove the safety locking screw of each hinge. Retain the screws for reinstallation later.



#### NOTE

*Adjusting the tension on the spring hinge is a two handed operation.*

3. To increase the tension, insert a 5/32" hex wrench in the screw socket. Turn the wrench clockwise to desired tension as well as aligning the locking screw hole. Hold the wrench in place, maintaining the selected tension, while reinstalling the locking screw.



#### NOTE

*Make sure the holes inside the hinges are aligned before inserting the locking screw.*

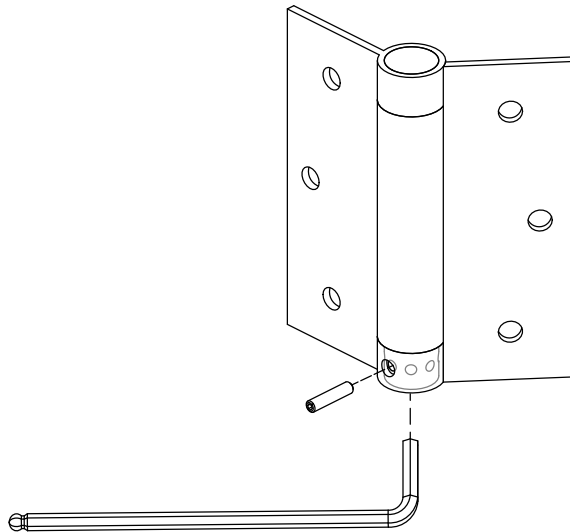

4. Adjust the tension on all hinges until the gate releases and latches from a half open position.

### 5.2-3 Railing Maintenance and Repair

Skyjack MEWPs have been designed to make sure compliance with the relevant design standards applicable for that particular unit at the time of manufacture. As such, any repairs made to the guardrail or basket structure need to make sure this compliance is not compromised and must return the structure to its original condition.

Any damage must be repaired by returning the railing assembly to its undamaged state. Damage includes, but is not limited to, the items listed below:

- bent/deformed guardrail sections
- cracks or broken welds in railing sections
- damaged pin connections
- missing pins or broken pin lanyards
- missing railing hardware
- loose or missing parts
- additional holes in guardrail sections other than those approved by Skyjack

Additionally, the guardrails must be properly positioned and secured, and the entry gate must be in good working order.

The strength of the guardrail system, and therefore its ability to provide fall protection for platform occupants, depends upon the design being secure and undamaged.

Skyjack railings are designed for modular replacement, and Skyjack recommends replacement of any damaged railing section. Skyjack-approved replacement parts will meet this requirement.

## 5.3 Base

### 5.3-1 System Relief Pressure Adjustment

1. Locate the system pressure fitting or quick disconnect port on the main manifold.
2. Install a calibrated 5000 psi gauge to the system pressure fitting or quick disconnect port.
3. At the main manifold, loosen the locknut on the system relief valve R1.
4. Remove black #14 wire from the lift coil 3H-14.
5. Turn the base/off/platform key switch to platform position.
6. Select lift with the lift/drive select switch on the platform control console.
7. Engage lift with the joystick and hold.
8. Observe reading on gauge. Adjust the R1 system relief value listed on the serial number plate. Turning the stem on the relief valve clockwise will increase pressure. Turning the stem counterclockwise will decrease pressure.
9. Release lift function and tighten the locknut.
10. Reconnect #14 wire onto the lift coil 3H-14.
11. Remove the gauge from system pressure test port.

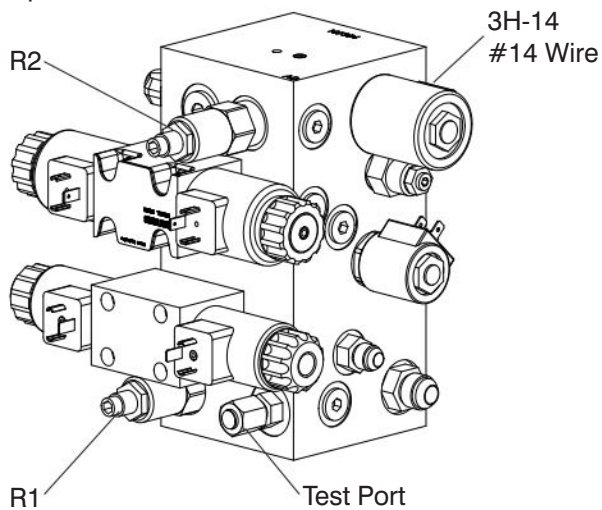

### 5.3-2 Pothole Compression Rod Replacement

It is important that new compression rods are adjusted to the correct height for the pothole protection system to work correctly.

#### Compression rod is too long

- Risk of the compression rod to be bent when the scissor stack comes down.
- The machine may not drive at all at certain heights, and the Skycoded display will show "POTHOLE - DRIVELOCKED!"

#### Compression rod is too short

- The pothole bar will not fully retract.

#### Adjust the compression rod

1. Loosen the lock nut and adjust the carriage bolt until the overall length of the compression rod assembly matches the dimension shown below.
2. The overall length is measure from the tip of the carriage bolt to the bottom of the compression rod.

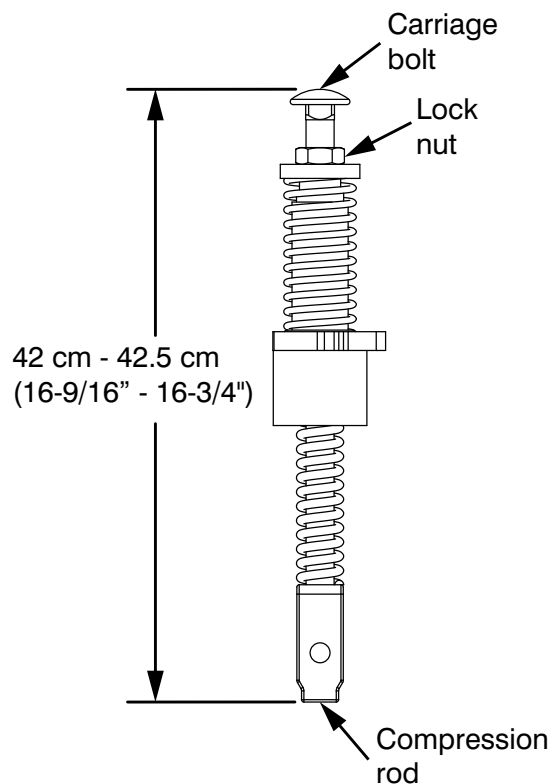

3. Hold the carriage bolt in place and tighten the lock nut.
4. Do a final check of the overall length and make sure it is still correct.

#### Test the compression rod

1. Raise the platform to the approximate height shown below and try to drive:
  - SJ3215/19 - 2.2 m to 2.8 m (7' 4" to 9' 2")
2. If the MEWP will not drive and the Skycoded display shows "POTHOLE - DRIVELOCKED!", make sure the overall length of the compression rods are correct, and the pothole limit switches are installed correctly ([5.3-3 Pothole Limit Switches \(LS1 & LS2\) Replacement and Adjustment](#)).



### 5.3-3 Pothole Limit Switches (LS1 & LS2) Replacement and Adjustment

#### Machine Preparation

1. Park the MEWP on a firm level surface.
2. Chock or block the wheels so the MEWP does not roll forward or backward.

#### Remove the Limit Switches

1. Raise the platform until the pothole bars are deployed.
2. Swing out the hydraulic tray and the battery tray to gain access to the pothole limit switches below the base.
3. Remove the bolts, washers and nuts (x2) that secure the limit switches to the pothole lock plates. Set the hardware aside for later reinstallation.

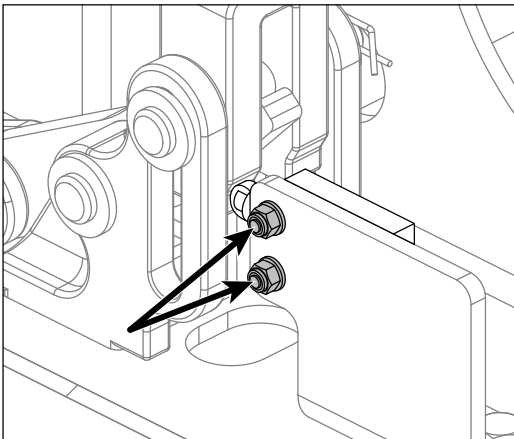

4. Remove the bolts and washers (x2) that secure the lock plates to the base. Set the hardware aside for later reinstallation.

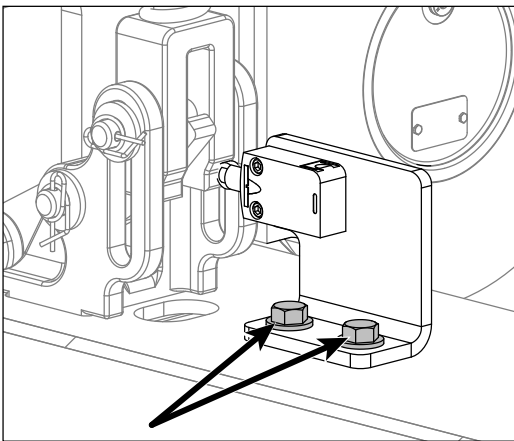

5. Remove the limit switches and free the limit switch cables. Cut tie wraps as necessary.
6. Follow the cable into the main harness.
7. Disconnect the limit switch wires from the main harness. Discard the limit switches.

#### Replace the Limit Switches

1. Install the new limit switches (210227 - Battery Tray & 210226 - Hydraulic Tray) to the lock plates using the hardware removed previously.
2. Make sure the distance between bottom of the limit switches and the top surface of the lock plates are 4.13 cm (1-5/8").

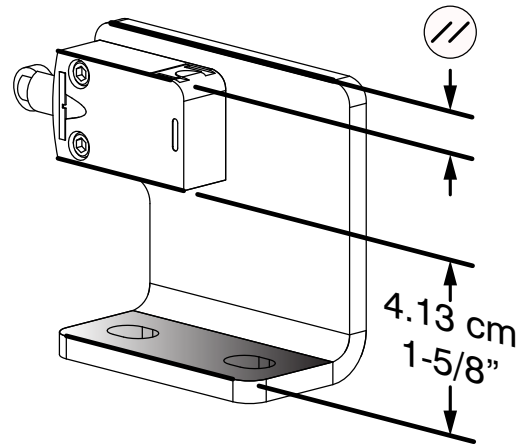

3. Make sure the limit switches are parallel with the edge of the lock plates.
4. Tighten the hardware on the limit switches before reinstalling the lock plates to the base.

#### Connect Limit Switch Wires

1. Route the new limit switch cable(s) along the same path as the old one(s) to the main harness. Secure the cables using tie wraps at regular intervals.
2. Plug the spade connectors into the same wire numbers. The #72 wires from each limit switch connects to each other. The #71 and #901 wires from the limit switches connect to the respective wires on the main harness.

### Adjust the Limit Switches

1. Install loosely the lock plates to the base using the hardware removed previously.
2. Use the slotted holes in the lock plates to move them back and forth until the limit switch plungers are barely touching the compression rods. Make sure the plungers are not pushed in.

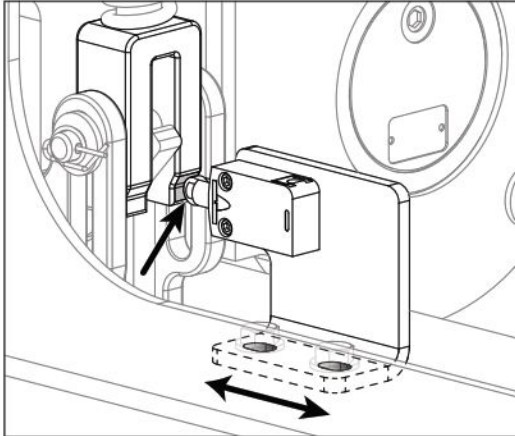

3. Tighten the hardware to secure the lock plates to the base. Make sure the limit switches do not move while you tighten the bolts and the plunger roller's retaining pins are fully visible.

### Test the Limit Switches

1. Place a block, approximately 3.75 cm (1-1/2"), under the hydraulic tray and raise the platform to an approximate height of 2 to 3 meters (7 to 10 feet) until the pothole protection limit switches are activated.
2. Select "Diagnostics" menu on the display module and scroll to the "Inputs" menu. Scroll to P4-7 to observe the pothole limit switch status. Make sure the I/O is correct.
  - ON when the pothole protection is on a block.
  - OFF when the pothole protection is fully lowered.
3. Attempt to drive forward or reverse. The MEWP should not move forward or backward when pothole protection is on a block.

### 5.3-4 Pothole Bar Replacement/Removal for Servicing

#### Prepare the machine

1. Make sure the MEWP is on firm, level ground.
2. Chock or block the wheels to keep the MEWP from rolling forward or backward.

#### Tools necessary

- Needle nose plier

#### How to install or remove a Rue Ring



Install into  
hole



Automatic  
lock



Optional  
manual lock



Push up and  
back to remove

#### Installation Instructions

1. Raise the scissor stack until the pothole bars are deployed and there is no tension on both pothole plungers.

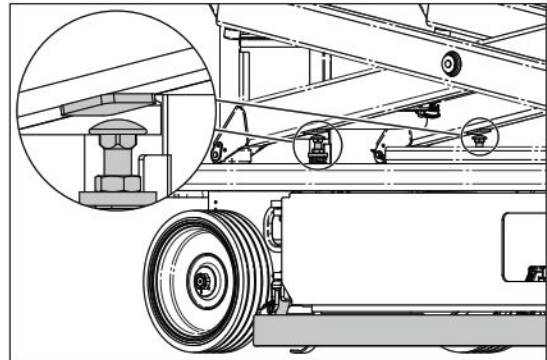

2. Remove the Rue Ring cotter pins and hardware that connects the pothole bar to the hydraulic and battery tray. Keep the pins and hardware.

3. Make sure the bushing is secured. Do an inspection on the bushing for excessive wear. Replace it if necessary.

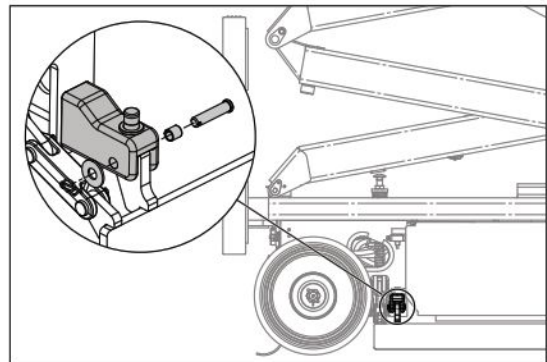

4. Pull the pothole bar to allow access to the next Rue Ring cotter pin.
5. Remove the pins and hardware that connects the pothole bar to the pivot point from the pothole protection assembly and base weldment. Keep the pins and hardware.

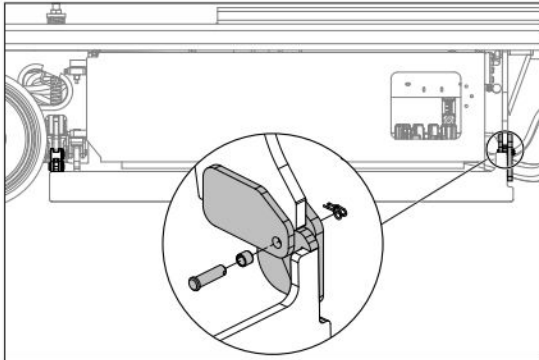
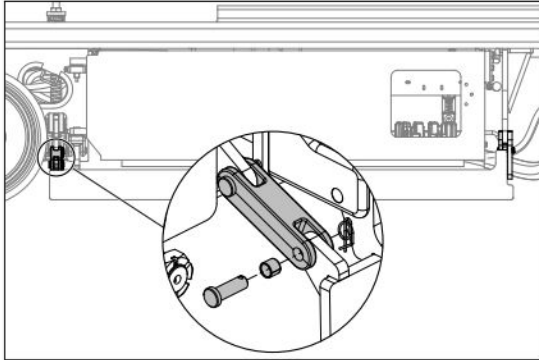

6. If replacing the pothole bar, remove and discard the old pothole bar.
7. Install a new pothole bar.
8. Re-install the pins and hardware to the pivot points on the pothole assembly and base.

### Test the pothole bars

1. Raise and lower the scissor stack a few times to make sure the pothole bars deploy correctly.

### 5.3-5 Tightening and Torque Recommendations for Hydraulic Couplings and Hoses

#### General Work Practices

1. All components must be free of damage or contamination. O-rings cannot be reused anytime the component has been installed beyond finger tight. Clean or replace components, as required.
2. Over-tightening a coupling may result in overstressing and/or cracking, and may lead to leaking or failure.
3. When tightening hose couplings, make sure the hose does not twist on the adapter. Twisting will shorten hose life and scar the sealing surfaces of swivel type couplings (JIC, 45°, etc.), which can create leaks.
4. When tightening hose couplings, use a torque wrench (with crow's foot) on the hose end hex swivel nut, and a standard box wrench on the hose end stem hex to hold the hose from twisting.

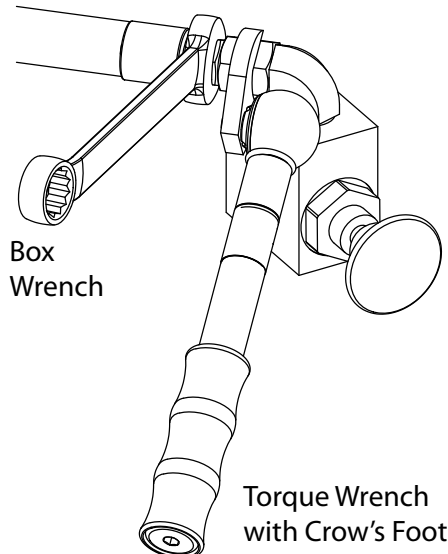

5. Lubricate all o-ring surfaces with suitable hydraulic oil prior to installation in the flange head and o-ring seal grooves. This will minimize the possibility of damage to the O-ring when installed.
6. Install any 45° and 90° hydraulic hose ends first, then align direction and tighten. Adjust the swivel nut on the straight hose end before tightening to create the desired flow.

#### Torquing Using a Torque Wrench

1. This method is applicable for JIC (37°) and FFOR (Flat Face O-Ring) hose ends and fittings, wherever the components are accessible with torque wrench / crow's foot tools.
2. Align the hose end or fitting to the mating component.
3. Install the nut two or three turns by hand to assure proper alignment. Jiggle the hose while tightening to make sure the faces contact fully.
4. Using a properly calibrated torque wrench, tighten the coupling using a smooth, even motion until an indication (audible click) is heard and felt. Do NOT over tighten. For recommended torque values, refer to [2.4 Torque Specifications for Hydraulic Couplings & Hoses](#).
5. Apply a drop of torque seal to the connection.

#### Torquing Using the Flats From Wrench Resistance Method

1. This method is applicable for JIC (37°) and FFOR (Flat Face O-Ring) hose ends only, wherever the components are inaccessible with torque wrench/ crow's foot tools, or when a properly calibrated torque wrench is not available.
2. Align the hose end or fitting to the mating component.
3. Install the swivel hose end nut hand tight to the fitting to assure proper alignment. Jiggle the hose while tightening to make sure the faces contact fully.
4. Tighten the nut using a box wrench until minor resistance is felt.

- Note the position of the nut relative to the fitting with a marking device (i.e., paint marker).

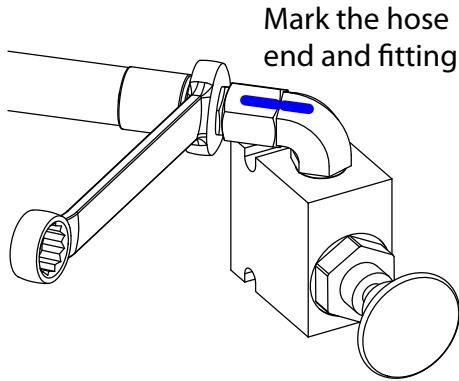

- Referencing the chart below, use a second box wrench to tighten the nut the appropriate number of flats past the mark. Do NOT over tighten.

FLATS FROM WRENCH RESISTANCE CHART for JIC Hose Ends			
Size		FFWR	
Dash	Frac. (in.)	37° Tube Nut	Swivel Nut
-4	1/4"	2	1.5
-5	5/16"	2	2
-6	3/8"	1.5	1.5
-8	1/2"	1.5	1.25
-10	5/8"	1.5	-
-12	3/4"	1.25	-
-16	1"	1	-
-20	1 1/4"	1	-
-24	1 1/2"	1	-
-32	2"	1	-

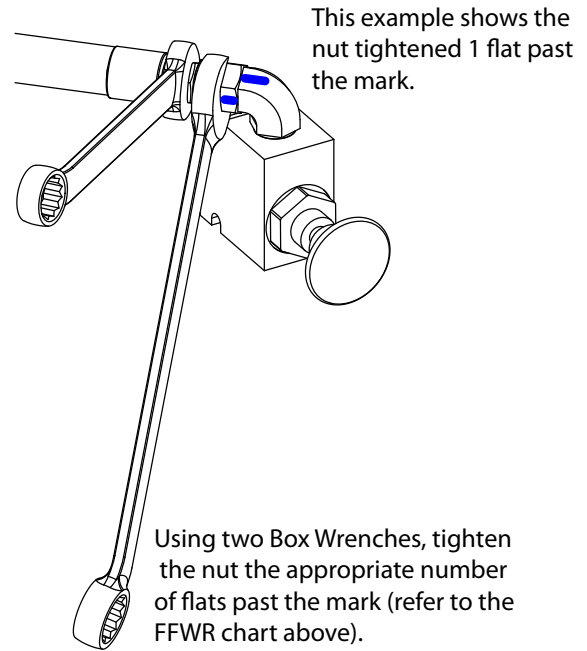

- Apply a drop of torque seal to the connection.

### 5.3-6 Integrated Hub Wheel Removal and Installation

#### Tools Needed

- Adjustable Torque Wrench  
Capacity 203 Nm (150 ft-lb)
- Hub Puller

#### Grease Application - New Rear Wheels with Pin Brakes Only (if required)

Model	Recommended Grease Type
SJ3215, SJ3219	STARPLEX EP2
	UNIREX EP2
	SHELL GADUS S2

1. If the bearings are provided separately, they will need to be coated in grease before installing on the front wheels.

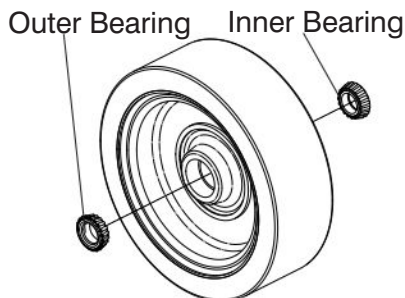

Front side shown

2. Thoroughly clean the bearings using solvent and allow them to dry.
3. Coat the inner and outer bearings with grease completely. Be careful not to contaminate the grease. This could cause internal damage and shorten the life span of the bearings. Contaminants include dust, dirt, sand, water or other foreign particles.
4. Install the inner and outer bearings. The grease should allow the bearings to stick to the bearing cups inside the wheel assembly.



#### NOTE

The inner bearing has a larger diameter than the outer bearing. When installing, make sure the bearings are inserted tapered-end first.

5. From the back side of the wheel, place the grease seal on the hub with the tapered end facing inwards.

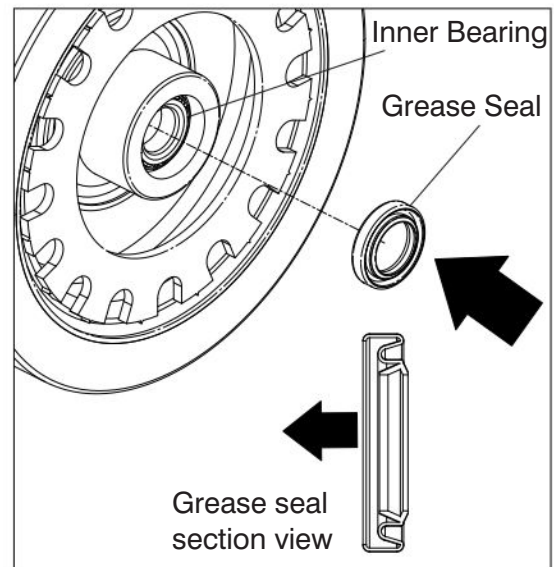

Back side shown

6. Lightly tap the grease seal into place using a hammer, protecting the grease seal with a flat piece of wood.

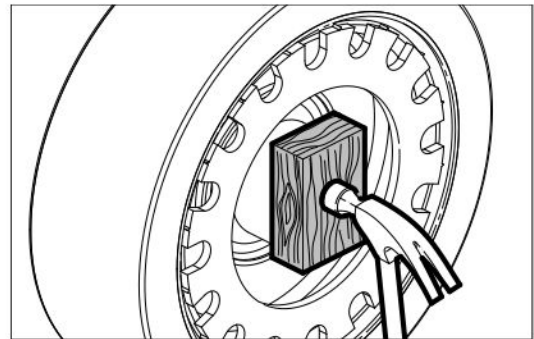



### Integrated Hub Wheel Removal

1. Use an appropriately rated lifting device to raise up the MEWP until all the wheels are off the ground. Set the MEWP on stands adequately rated to support the weight of the machine.
2. Remove and set aside the wheel motor nut or castle nut.
3. Remove and discard the locktooth washer or cotter pin. A new one will be required for re-installing the hub/integrated hub wheel.
4. Use two 3/8"-24 bolts with a hub puller to remove the wheel.

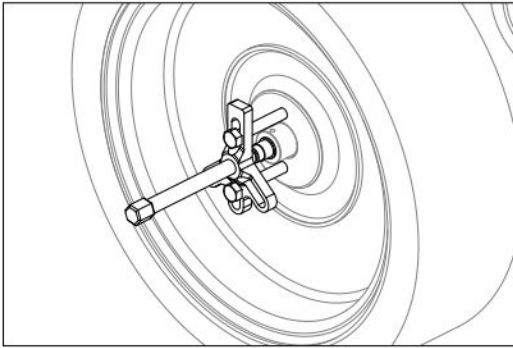

5. Use a hub puller to remove and discard the hub/integrated hub wheel from the wheel motor or brake.

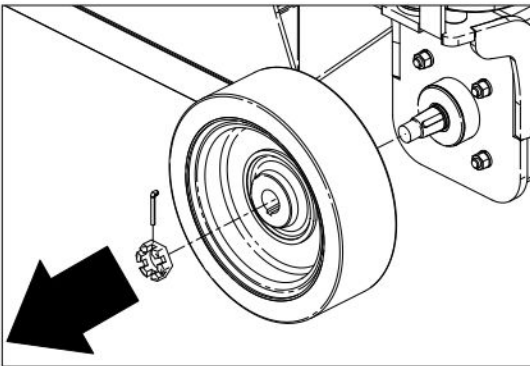

### Front Integrated Hub Wheel Installation

1. Install the integrated hub wheel onto the spindle.
2. Install the castle nut. Finger tighten the nut.
3. Tighten the castle nut to 203 Nm (150 ft-lb).
4. Insert a 1/8" x 1-1/2" cotter pin.
5. If the holes do not align to install the cotter pin, continue to torque the castle nut clockwise until the next hole is visible.
6. Make sure the cotter pin is pushed in completely.
7. Bend the ends of the cotter pin to secure the castle nut.

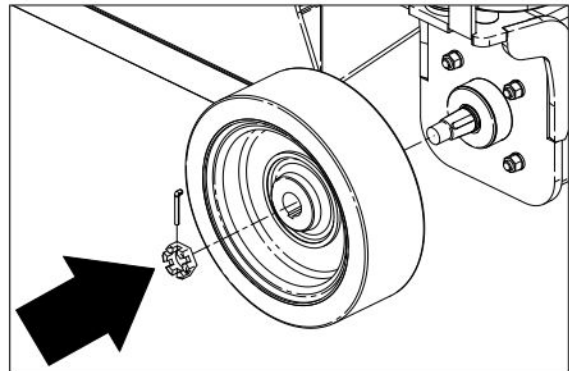

8. To limit rust bleed, it is recommended that a few drops of grease be applied to the two small tapped holes on the front wheels.

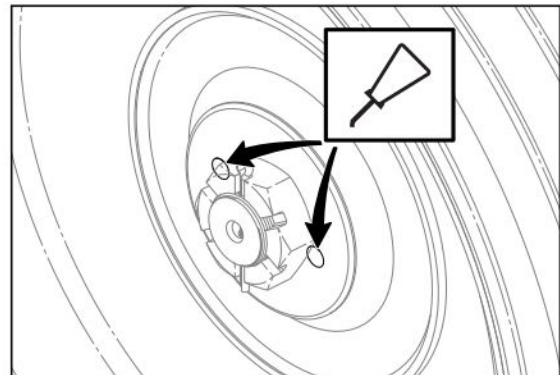



## Rear Integrated Hub Wheel Installation - Pin Brakes

1. Install the integrated hub wheel onto the spindle.
2. Install the castle nut and the flat washer. Finger tighten the nut.
3. Use a wrench to manually disengage the pin brakes on both sides. This will allow you to rotate the wheel.
4. Rotate the hub/wheel slowly while tightening the castle nut to approximately 68 Nm (50 ft-lb). This is to seat all the bearings in the wheel assembly.
5. Loosen the castle nut to remove the torque. Do not rotate the wheel.
6. Finger tighten the castle nut until it is snug.
7. Use a wrench to re-engage the pin brakes on both sides. Do not lower the machine while the pin brakes are disengaged.
8. Turn the castle nut back slightly until the next cotter pin hole is visible on the spindle.
9. Install a 1/8" x 1-1/2" cotter pin. Make sure the cotter pin is pushed in completely to allow the dust cap to fit.
10. Bend the ends of the cotter pin to secure the castle nut.
11. Install the dust cap over the castle nut. Be sure not to damage the castle nut while installing the dust cap.



### NOTE

*Do not over-torque the castle nut as the bearing life would be reduced.*

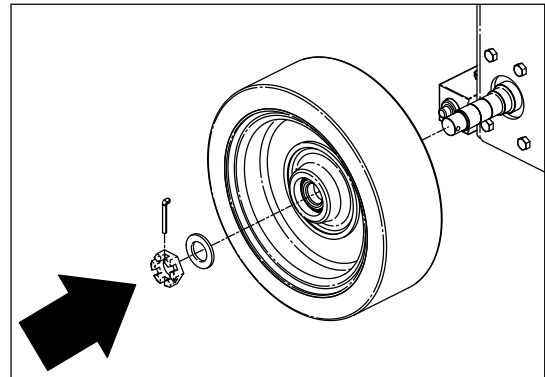
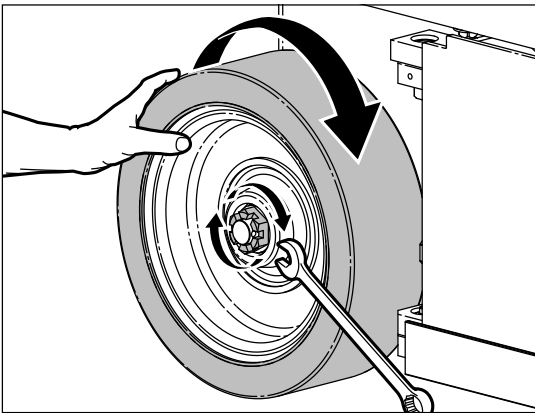

### Rear Integrated Hub Wheel Installation - Wet Brakes

1. Install the integrated hub wheel onto the spindle.
2. Install a 1" castle nut onto the brake.
3. Tighten the castle nut to 203 Nm (150 ft-lb)
4. Insert a 1/8" x 1-1/2" cotter pin.
5. If the holes do not align to install the cotter pin, continue to torque the castle nut clockwise until the next hole is visible.
6. Make sure the cotter pin is pushed in completely.
7. Bend the ends of the cotter pin to secure the castle nut.

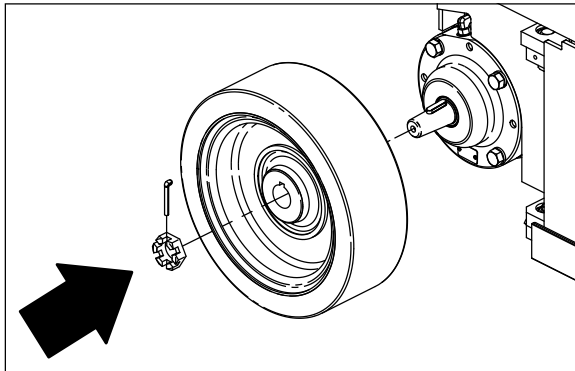

### 5.3-7 Battery Maintenance

This section provides the operator with procedures on how to service and charge the battery. This also provides the charger operation instructions.

#### Servicing the battery

#### WARNING



**Explosion hazard. Keep flames and sparks away. Do not smoke near batteries. Battery acid releases explosive gas while charging. Charge batteries in a well-ventilated area.**

#### WARNING

**Battery acid is extremely corrosive – wear proper eye and facial protection as well as appropriate protective clothing. If contact occurs, immediately flush with cold water and seek medical attention.**

1. Turn the main power disconnect switch to the off position.
2. Check the battery case for damage.
3. Check the battery fluid level in each battery. If the plates are not covered by at least 13 mm (1/2 in) of solution, add distilled or demineralized water.
4. Make sure all the battery connections are tight.

#### NOTE

*Do not use any batteries other than the flooded lead-acid batteries of the proper Ah rating.*

#### WARNING

**Use the original or equivalent to the original parts and components for the MEWP.**

### 5.3-8 Charger Maintenance

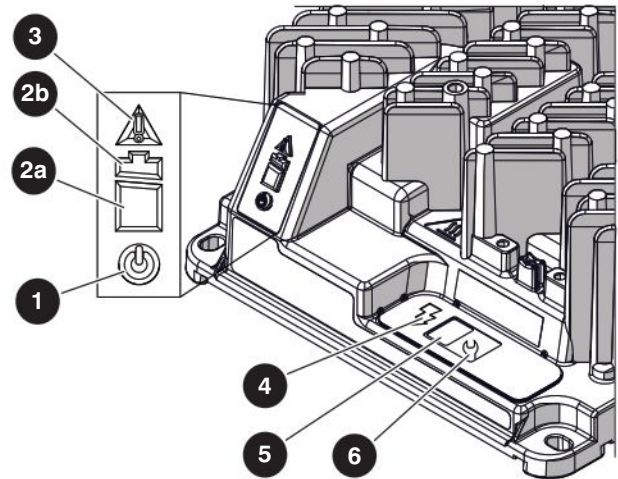

No.	Indicator type	Condition	Description
1	AC power	Blue	Battery charger is connected to the AC power.
2a	Battery charge <80%	Green flash	Low charge— continue to charge.
		Solid green	High charge— continue to charge.
2b	Battery charge >80%	Green flash	High charge— continue to charge or stop the charge.
		Solid green	Charge complete— stop the charge.
3	Fault/ error	Solid red	Charger fault—refer to the service manual.
		Amber flash	Error found—refer to the service manual.
4	Charge output	Solid yellow	Charger output is on.
5	Charge profile/ error display	Algorithm or fault/ error code	N/A.
6	Select charge profile	Charge algorithm	N/A.

## Charger Profiles

### IMPORTANT

Charge profiles differ depending on the battery type and manufacturer. Only use charge profiles with the batteries they were designed for. Using other incompatible batteries may cause poor charging performance and a decreased battery health.

- Place the charger near a power outlet, but leave it unplugged.
- Find your battery type in the following chart, and make a note of the profile number (starting with P).
- Press and hold the Select Charger Profile button (wrench icon) on the Delta-Q charger. You will hear a small click when you press the button.
- Continue to hold the Select Charger Profile button, and connect the charger to a power outlet.
- Continue to hold the button for approximately 10 seconds or until the Error Indicator turns orange and the Battery Charging Indicator starts flashing green.
- The current charger profile displays up to three times.



### NOTE

*The process times out and the profile remains unchanged if there are 15 seconds of inactivity, or if the charging profile is allowed to display three times.*

- Press and release the button to scroll through the charging profiles.
- Select a profile, and press and hold the button for 10 seconds or until the Error Indicator and Battery Charging Indicator lights turn off.
- Press the button again to confirm the selected profile.
- Disconnect the charger from the power outlet.

Battery Brand	Compatible with	Profiles
U.S. Battery - US 2200 XC/XC2 Flooded, 6V, 232 Ah	200 - 255 Ah flooded	#11 (P-0-1-1)
East Penn - 8GGC2 Gel, 6V, 180 Ah	150 - 230 Ah gel	#26 (P-0-2-6)
Discover Energy - EVGC6A-A AGM, 6V, 220 Ah	220 - 400 Ah AGM	#43 (P-0-4-3)
Discover Energy - EV12A-A AGM, 12V, 140 Ah*		
U.S. Battery - US 12V XC2 Flooded, 12V, 155 Ah*	330 - 425 Ah flooded	#73 (P-0-7-3)
U.S. Battery - US 250 XC/XC2 Flooded-lead, 6V, 255 Ah		
Trojan - T105 ELPT Flooded, 6V, 225 Ah	150 - 250 Ah 6V, 8V, 12V flooded	#3 (P-0-0-3)

\*The batteries used for these charger profiles are connected in a series-parallel circuit.

## Charger Troubleshooting

The IC Series charger is continuously monitoring itself and its environment for unusual conditions. There are a few indications that may require the user's attention.

Symptom	Recommended Action
No Indicator Lights	Check AC voltage and connection to wall power.
Only Blue AC Light On	Charger is connected to AC and is waiting for a battery to be connected, or for CAN remote control commands. Battery voltage must rise over 0.1V/cell before charging will begin. Some charging algorithms require a higher battery voltage to begin.
Solid Red Fault/Error Indicator	Read fault code (e.g., F-0-0-1) number on the Charge Algorithm/Error Display and refer to the fault code table.
Flashing Amber Fault/Error Indicator	Read error code (e.g., E-0-0-1) number on the Charge Algorithm/Error Display and refer to the error code table.

## Charger Fault Codes

Fault Code	Description	Troubleshooting/Customer Actions
F-0-0-1	DC-DC Failure: LLC excessive leakage fault.	Internal charger fault. Disconnect AC and battery from charger for a minimum of 30 seconds. If it fails again, contact Skyjack service.
F-0-0-2	Power Factor Correction (PFC) Failure: PFC excessive leakage fault.	
F-0-0-3	PFC has taken too long to boost.	
F-0-0-4	The charger has been unable to calibrate the current offset.	
F-0-0-5	The voltage drop across the DC relay is too high while the relay is closed.	
F-0-0-6	Large difference between internal DC-DC and battery sense currents.	

## Charger Error Codes

Fault Code	Description	Troubleshooting/Customer Actions
E-0-0-1	Battery voltage over limit in software. Typically 2.5V/cell. At the start of a charger cycle only and only for lead acid batteries. It is acceptable for the voltage to go above this during charging and when charging Lithium batteries.	<ul style="list-style-type: none"> <li>▪ Check the battery voltage and cable connections.</li> <li>▪ Check charger voltage model is appropriate for batteries.</li> <li>▪ This error automatically clears once the condition has been corrected.</li> </ul>
E-0-0-2	Battery voltage too low to start a charge cycle. Algorithm dependent. Typically 0.1V/cell.	<ul style="list-style-type: none"> <li>▪ Check the battery voltage and cable connections.</li> <li>▪ Check the charger is the correct voltage for the batteries it is connected to.</li> <li>▪ Check battery size and condition. Batteries may be overdischarged. Use another charger to bring the batteries above the minimum voltage.</li> <li>▪ This error automatically clears once the condition has been corrected.</li> </ul>
E-0-0-3	Charge time limit reached. Algorithm dependent.	<ul style="list-style-type: none"> <li>▪ Charger output reduced due to high temperatures. Operate at lower ambient temperature.</li> <li>▪ Charger output reduced due to low AC voltages. Check AC voltages.</li> <li>▪ Check for shorted or damaged cells.</li> <li>▪ Poor battery health. Replace the battery.</li> <li>▪ Batteries too large for the charger. Replace batteries.</li> <li>▪ Very deeply discharged battery. Retry charge.</li> <li>▪ Battery connections are loose or corroded. Check connections.</li> <li>▪ Extra loads. Turn off other devices running on the battery</li> <li>▪ This error automatically clears once the charger is reset by cycling DC or by loss of AC for over 10 minutes.</li> </ul>
E-0-0-4	Battery could not be trickle charged up to the minimum voltage. May also be used for other battery-related errors depending on the algorithm.	<ul style="list-style-type: none"> <li>▪ Check for shorted or damaged cells.</li> <li>▪ Poor battery health. Replace the battery.</li> <li>▪ Check DC connections.</li> <li>▪ May be caused because of output reduced due to high temperature.</li> <li>▪ Some new batteries may trigger these alarms as there voltage dips</li> <li>▪ when charging starts before it goes onto rise.</li> </ul>
E-0-0-7	Charge amp-hour Limit reached. Algorithm dependent.	<ul style="list-style-type: none"> <li>▪ Charger output reduced due to high temperatures. Operate at lower ambient temperature</li> <li>▪ Charger output reduced due to low AC voltages. Check AC voltage.</li> <li>▪ Check for shorted or damaged cells.</li> <li>▪ Poor battery health. Replace the battery.</li> <li>▪ Very deeply discharged battery. Retry charge.</li> <li>▪ Battery connections are loose or corroded. Check connections.</li> <li>▪ Extra loads. Turn off other devices running on the battery</li> <li>▪ This error automatically clears once the charger is reset by cycling</li> <li>▪ DC or by loss of AC for over 10 minutes.</li> </ul>

E-0-0-8	Battery temperature out of range. Algorithm dependent.	<ul style="list-style-type: none"> <li>▪ Cool or warm batteries as needed.</li> <li>▪ Check temperature sensor and connections.</li> <li>▪ This error automatically clears once the condition has been corrected.</li> </ul>
E-0-1-1	Charge disabled by external command	<ul style="list-style-type: none"> <li>▪ Charger has been disabled by an external controller over the CANbus network.</li> <li>▪ This error automatically clears once the command has been removed.</li> </ul>
E-0-1-2	Reverse polarity	<ul style="list-style-type: none"> <li>▪ Battery is connected the wrong way around. Check the battery connections.</li> <li>▪ This error automatically clears once the condition has been corrected.</li> </ul>
E-0-1-3	Battery does not take current	<ul style="list-style-type: none"> <li>▪ Check for an electrical component or loose connection between the charger and the battery.</li> <li>▪ When charging lithium batteries, make sure the charger is properly connected to the battery and battery management system.</li> <li>▪ This error automatically clears once the charger is disconnecting DC or AC.</li> </ul>
E-0-1-9	Hardware build does not support software version	<ul style="list-style-type: none"> <li>▪ The charger hardware does not support the new software version.</li> <li>▪ Existing SW is left running. Contact Delta-Q Technologies.</li> </ul>
E-0-2-0	No active algorithm selected	<ul style="list-style-type: none"> <li>▪ Reprogram the charger with its original software, algorithms, and settings.</li> <li>▪ Use the wrench button to select the correct algorithm if still available on the charger.</li> <li>▪ The problem clears automatically when an available algorithm is set on the charger, as default.</li> </ul>
E-0-2-1	High battery voltage while charging. Algorithm dependent. Typically 2.8V/cell.	<ul style="list-style-type: none"> <li>▪ When already charged, some new batteries may exhibit this error.</li> <li>▪ Disconnect the battery connection and wait for the battery voltage to fall. Reconnect the batteries to see if the condition reoccurs.</li> <li>▪ Check battery size and condition. Batteries in poor condition, with a high internal resistance, may cause this error. New batteries, if charged when already full, may also cause this error. Disconnect and reconnect the batteries a few times.</li> <li>▪ Check the battery voltage and cable connections.</li> <li>▪ This error automatically clears once the condition has been corrected.</li> </ul>

E-0-2-2	Low battery voltage while charging. Algorithm dependent. Typically 0.1V/cell.	<ul style="list-style-type: none"> <li>▪ Another device may be drawing current from the battery.</li> <li>▪ Check the battery voltage and cable connections.</li> <li>▪ Check battery size and condition. Batteries may be overdischarged.</li> <li>▪ Use another charger to bring the batteries above the minimum voltage.</li> <li>▪ This error automatically clears once the condition has been corrected.</li> </ul>
E-0-2-3	High AC voltage error (>270 VAC)	<ul style="list-style-type: none"> <li>▪ AC voltage is too high. Connect charger to an AC source that has a stable AC voltage between 85 and 270 VAC/45-65 Hz.</li> <li>▪ In newer software versions this does not prevent charging.</li> <li>▪ This error will automatically clear once the condition has been corrected.</li> </ul>
E-0-2-4	Charger failed to turn on properly	<ul style="list-style-type: none"> <li>▪ Disconnect AC input and battery for 30 seconds. If the error persists, contact Delta-Q Technologies.</li> </ul>
E-0-2-5	AC voltage has dipped below 80 VAC 3 times in 30 seconds	<ul style="list-style-type: none"> <li>▪ AC source is unstable. This could be caused by an undersized generator and/or input cables that are too long or too small.</li> <li>▪ Connect the charger to an AC source with a stable AC voltage between 85 and 270 VAC/45-65 Hz.</li> <li>▪ This error will automatically clear once the condition has been corrected.</li> </ul>
E-0-2-8	Attempt to select algorithm incompatible with this software	<ul style="list-style-type: none"> <li>▪ Update charger software, continue to use existing algorithm* or select a different charging algorithm that is compatible.</li> </ul> <p><b>* Notes</b></p> <ul style="list-style-type: none"> <li>▪ If selecting a different algorithm, the existing algorithm will remain in the charger.</li> <li>▪ If upgrading an existing algorithm, the existing algorithm will be deleted. Contact Delta-Q Technologies for a software upgrade to run the new algorithm.</li> </ul>
E-0-2-9	Cannot transmit on CAN bus	<ul style="list-style-type: none"> <li>▪ Check the physical CAN connector, electrical bus conditions, and other CAN modules for correct functioning. For example, check that termination resistance is approximately 60 ohms.</li> </ul>
E-0-3-0	CAN heartbeat timeout on Battery module	<ul style="list-style-type: none"> <li>▪ May be caused by a missing heartbeat message. Check the CAN bus battery module for correct function.</li> <li>▪ This error automatically clears once the condition has been corrected.</li> </ul>
E-0-3-1	The Vref for the ADC measurements has triggered an alarm	<ul style="list-style-type: none"> <li>▪ Internal charger error. Disconnect AC and the battery for a minimum of 30 seconds and retry.</li> <li>▪ If the problem persists, contact Delta-Q Technologies.</li> <li>▪ This error automatically clears once the condition has been corrected.</li> </ul>



E-0-3-2	CAN Heartbeat Lost	<ul style="list-style-type: none"> <li>▪ An error was detected with the CAN heartbeat communications with a registered node being guarded.</li> <li>▪ Check the networked CANbus device(s) for correct functioning.</li> <li>▪ This alarm does not display or get logged on the charger but does appear on the CAN bus via an emergency message.</li> </ul>
E-0-3-6	Battery temperature sensor is missing or shorted	<ul style="list-style-type: none"> <li>▪ Check sensor connections.</li> <li>▪ The charger behavior when this fault occurs can be configured. OEMs may contact Delta-Q Technologies for more information.</li> <li>▪ This error automatically clears once the condition has been corrected.</li> </ul>
E-0-3-8	Fan will not turn	<p>(Fan-equipped models only)</p> <ul style="list-style-type: none"> <li>▪ Check fan connections.</li> <li>▪ Check to make sure the fan turns freely and is not obstructed.</li> <li>▪ This error automatically clears once the condition has been corrected.</li> </ul>
E-0-4-0	Fan voltage pulled low	<p>(Fan-equipped models only)</p> <ul style="list-style-type: none"> <li>▪ Check to make sure the fan turns freely.</li> </ul>
E-0-4-5	Battery disconnected	<ul style="list-style-type: none"> <li>▪ Battery disconnected</li> <li>▪ Reconnect the battery or check the wiring</li> </ul>
E-0-4-6	Invalid PDO Length	<ul style="list-style-type: none"> <li>▪ Check to make sure all PDOs are valid length.</li> <li>▪ This error automatically clears once the condition has been corrected</li> </ul>
E-0-4-7	Platform overvoltage alarm	<ul style="list-style-type: none"> <li>▪ A battery or some other source has been connected to the charger that exceeds the hardware's design limits.</li> </ul>

## 5.4 Skycoded Module

### 5.4-1 Skycoded Control Module (CM1)

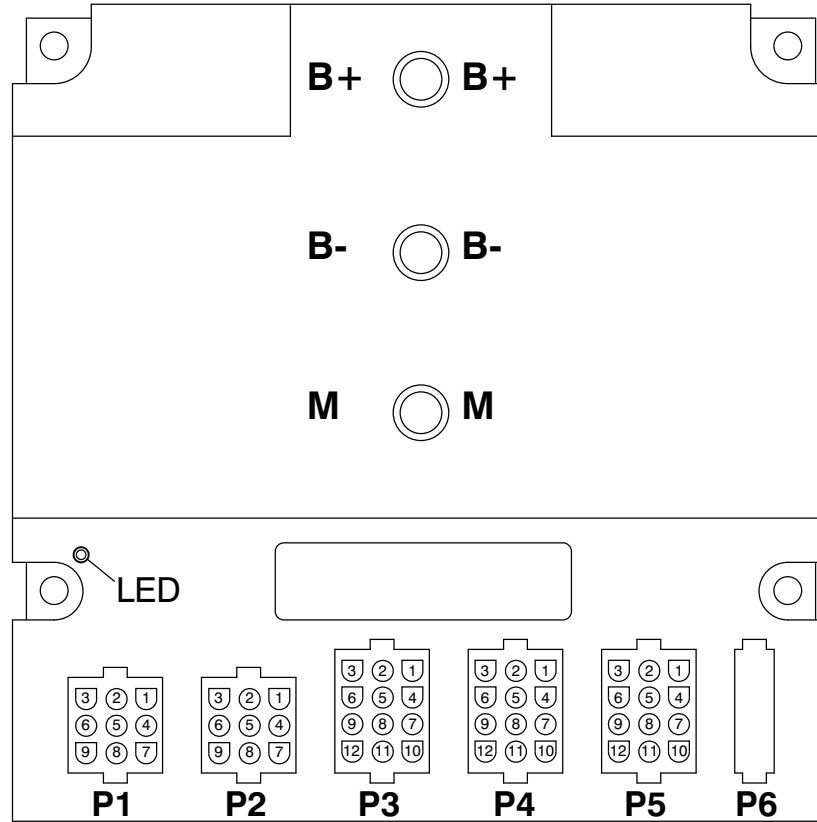

Skycoded Control Module CM1

#### Skycoded Control Module CM1

The Skycoded Control Module (CM1) is a flexible control system, which provides high-side switched outputs for the valves and contactor, proportional outputs and pulse width modulated (PWM) outputs for the pump/motor, and low-side outputs for indicator lamps, etc. It also provides active-high inputs from operator controls and analog inputs from joysticks and sensors. The control module has specific Skyjack software and flashed memory for use with load sensing and overload prevention.

Due to its integral tilt sensor, the control module is mounted securely below the base at the center of the machine, and can be located by swinging out the hydraulic tray.

Factory calibrations for height, load, and level are completed at Skyjack and only needs to be adjusted if a major component (i.e. the control module, etc.) has been replaced.

#### Calibration and Initial Set-up Procedures

Level

- [5.4-7 Calibrate Level Procedure](#)

Load

- [5.4-8 Calibrate Load Procedure](#)

Initial Set-ups and Change Defaults - Do this when you replace the control module

- [5.4-5 Initial Set-up and Change Defaults Procedure](#)

**Skycoded Control Module Pin Chart**

PLUG	PIN #	WIRE # AND COLOUR	PIN OUT
B+		03B Black	Lug for 24V supply voltage (from C1 Motor Contactor relay N.O. contact)
B-		00 Black	Lug for 0V reference from Battery negative (negative bus bar)
M		M- Black	Lug for Output of Pulsed Negative (-) to initialize Pump Motor
<b>Outputs and Analog Inputs</b>			
P1	1	08B Green	5V supply to Joystick PCB P8
P1	2	59 Orange/Black	0-5V Proportional Input from Joystick Analog PCB Output P7
P1	3	00B White/Black	0V reference to Joystick PCB P6
P1	4	19D White/Red	Input for Shutdown signal from Elevate Trackunit Telematics option (if equipped)
P1	5	CAN H	Communication CANbus High (if equipped)
P1	6	CAN L	Communication CANbus Low (if equipped)
P1	7	Not Used	Not Used
P1	8	60 Red/White	0V Reference Output (pulsed) for PL-1 Overload Light & PL-2 Overload Light
P1	9	29 Blue/Yellow	0V Reference Output (pulsed) for BP-29 Beeper for All-Motion, Tilt and Overload
<b>Connects to Sensors</b>			
P2	1	Not Used	Not Used
P2	2	28 Green/Red	0-5V Proportional Input from AT1 Angle Transducer Analog Output signal (3.7 Volts when stowed)
P2	3	Not Used	Not Used
P2	4	60A Black/Red/ Green	0-5V Proportional Input from PT1 Pressure Transducer Analog Output signal
P2	5	28A Green/Red	0-5V Proportional Input from AT1 Angle Transducer Analog Output signal (3.7 Volts when stowed)
P2	6	Not Used	Not Used
P2	7	910 Black	Output supply 24V (B+) for AT1, PT1 Transducers, Pothole Protection Limit switches LS1, LS2, and Beeper BP-29
P2	8	00C White	0V Reference Output to Holding Solenoids (2H-13-1 & 2H-13-2)
P2	9	22 Orange/Blue	0V Reference Output (pulsed) to FL-22 Flashing Light
<b>Platform Controls</b>			
P3	1	08C Purple/White	24V Input from S10 Idle/PLTF/Base Key Switch for Platform and/or Base signal ** required input for any movement **
P3	2	08 Blue/White	24V Input B+ Valve supply IF BOTH Emergency Stops are energized (supplies all valve outputs) ** required input for any movement from Platform **
P3	3	18 Red/Black	24V Input from S27 Torque Switch for High Torque signal
P3	4	120 Black	24V Input from S17 Indoor Select switch for Indoor signal (if equipped)
P3	5	10 Blue/White	24V Input from S10 Idle/PLFT/Base Key Switch for Base signal
P3	6	12 Blue	24V Input from S3 Lift/Off/Drive Switch for Drive signal
P3	7	09 Orange	24V Input from S3 Lift/Off/Drive Switch for Lift signal
P3	8	23 Black/White	24V Input from S7-2 Joystick PCB P3 Steer Right signal
P3	9	24 Blue/Black	24V Input from S7-3 Joystick PCB P1 Steer Left signal
P3	10	51A White	(KC built machines only) 24V Input from Anti-Overriding Limit switches N.O. contacts

**Skycoded Control Module Pin Chart (Continued)**

PLUG	PIN #	WIRE # AND COLOUR	PIN OUT
P3	11	51 Black	(KC built machines only) 24V Input from Anti-Overriding Limit switches N.C. contacts
P3	12	08A Black	24V Input from S7-6 Joystick PCB P4 Enable signal
<b>Base Control</b>			
P4	1	13B Orange	24V Input from S51 Emergency Lowering Toggle Switch for counter
P4	2	Not Used	Not Used
P4	3	Not Used	Not Used
P4	4	13A Orange	24V Input from S2 Lift/Lower Toggle Switch for Down signal
P4	5	14A Black	24V Input from S2 Lift/Lower Toggle Switch for Up signal
P4	6	Not Used	Not Used
P4	7	71 Blue/Red	24V Input from LS1 & LS2 Pothole Protection Limit Switches closed (LS1 & LS2 contacts are in series)
P4	8	26 Green	24V Input from Power Deck Extend signal (if equipped)
P4	9	27 Black	24V Input from Power Deck Retract signal (if equipped)
P4	10	37 Green/White	24V Input for Charger Cutout Interlock switch
P4	11	Not Used	Not Used
P4	12	Not Used	Not Used
<b>Valve Outputs</b>			
P5	1	19 White/Red	24V Output for Motor Contactor Coil C1
P5	2	16 White/Black	24V Output for Forward Solenoid Valve 4H-16
P5	3	15 Blue	24V Output for Reverse Solenoid Valve 4H-15
P5	4	17 Blue/Red	24V Output for Brake Solenoid Valve 3H-17
P5	5	14 Black	24V Output for Up Solenoid Valve 3H-14
P5	6	24A Blue/Black	24V Output for Steer Left Solenoid Valve 4H-24A
P5	7	26B White	24V Output for Power Deck Extend Solenoid Valve 4H-26 (if equipped)
P5	8	23A Black/White	24V Output for Steer Right Solenoid Valve 4H-23A
P5	9	18A Red/Black	24V Output for Torque Mode Solenoid Valves 2H-18A, 2H-18A-1 & 2H-18A-2
P5	10	27B Black	24V Output for Power Deck Retract Solenoid Valve 4H-27 (if equipped)
P5	11	13C Orange	(CE built machines only) Output for Proportional Lowering Solenoid Valve 2H-13C
P5	12	13 Orange	12V Output for Holding Solenoid Valves 2H-13-1 & 2H-13-2
<b>HMI Connection (RS232)</b>			
P6	1	B+ Black	24V B+ supply to Display Module
P6	2	Rx Red	Rx Receive signal to Display Module
P6	3	Tx Green	Tx Transmit signal to Display Module
P6	4	902 White	0V GND Reference to Display Module, PT1 & AT1 sensors

### 5.4-2 Calibration and Diagnostic Tool Key Functions

#### **⚠ WARNING**

Only trained and authorized personnel shall be permitted to service an MEWP.

#### **⚠ WARNING**

Read all instructions closely before attempting each phase of the calibration procedure.

The Skycoded display module can be used to calibrate and diagnose MEWP issues.

The display module can be found in the hydraulic tray connected via the rear plug with a four-pin RS232 connection to the Control Module CM1 P6 connector. See 5.4-1 Skycoded Control Module (CM1) for wiring specifications on the Control Module CM1.

The display module utilizes a two-line display, which shows various menus and settings. The top line of the display describes the currently selected menu and the bottom line shows the currently selected item in that menu.

#### Skycoded Display Controls



Symbol	Key Function
	ESC/ENTER Buttons To move back and forth between menu and sub-menu
	LEFT/RIGHT Buttons Select menus and setting to be adjusted
	UP/DOWN Buttons Adjust setting values

Use the left and right arrows to scroll through the top level menu selections and press ENTER.

#### Initial State

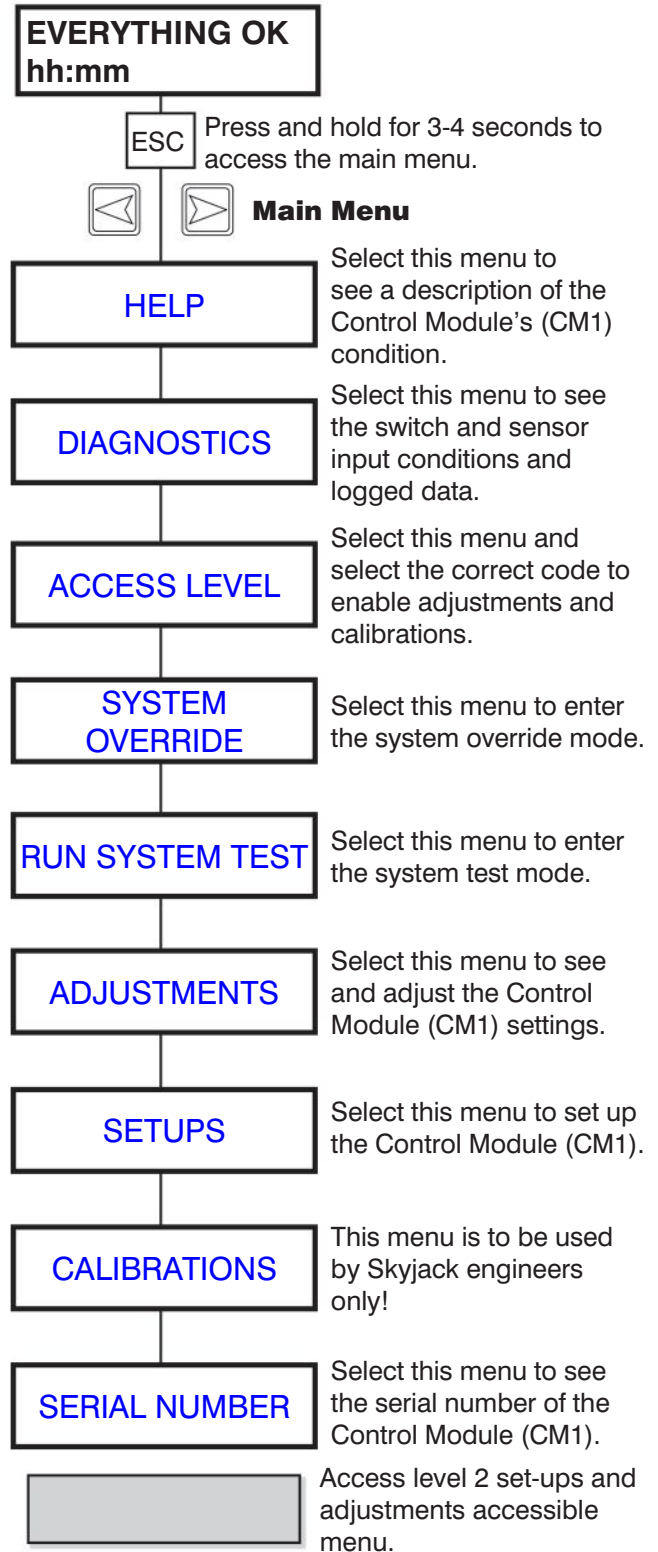

**Skycoded Controls - HELP/DIAGNOSTICS**

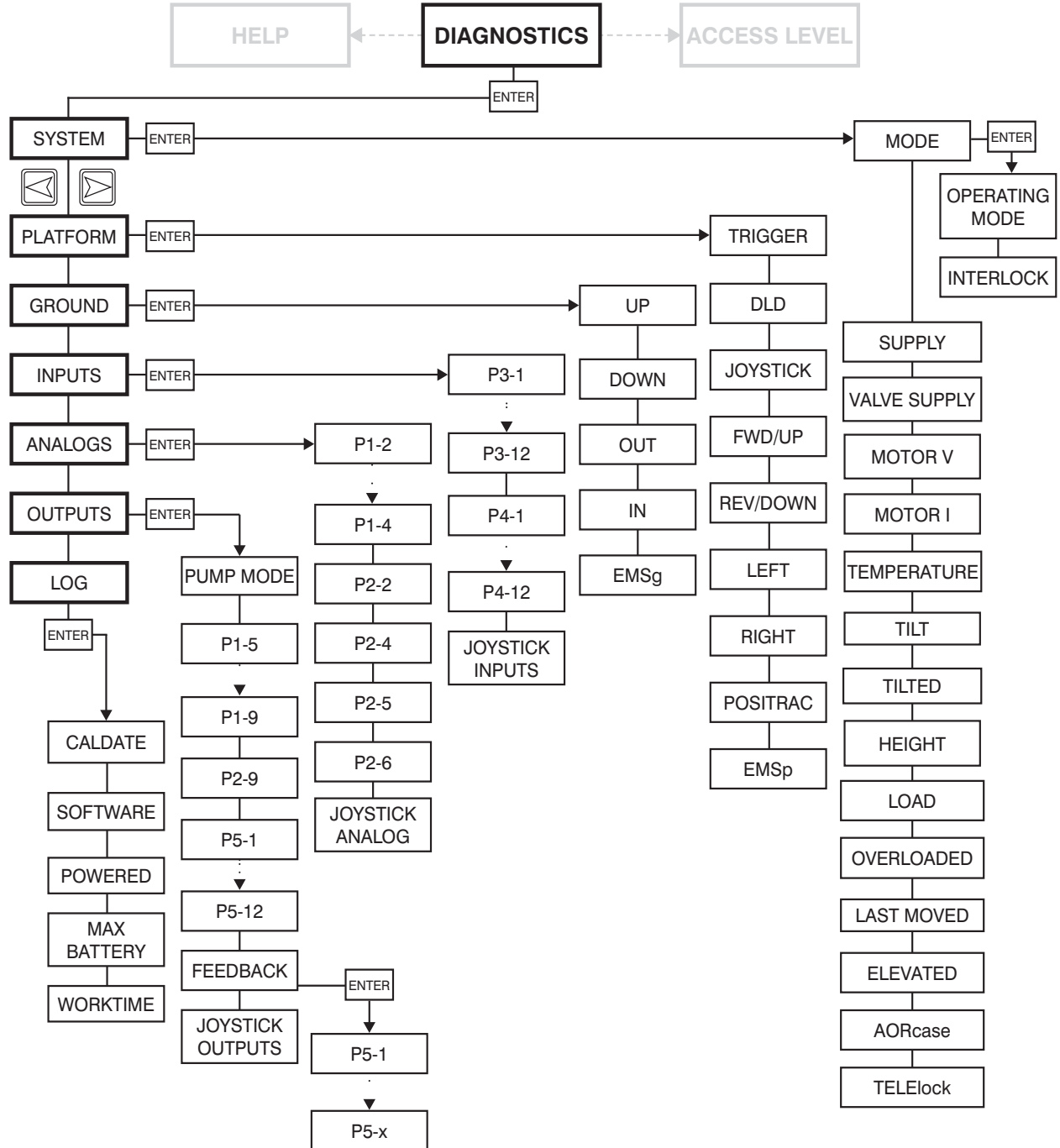
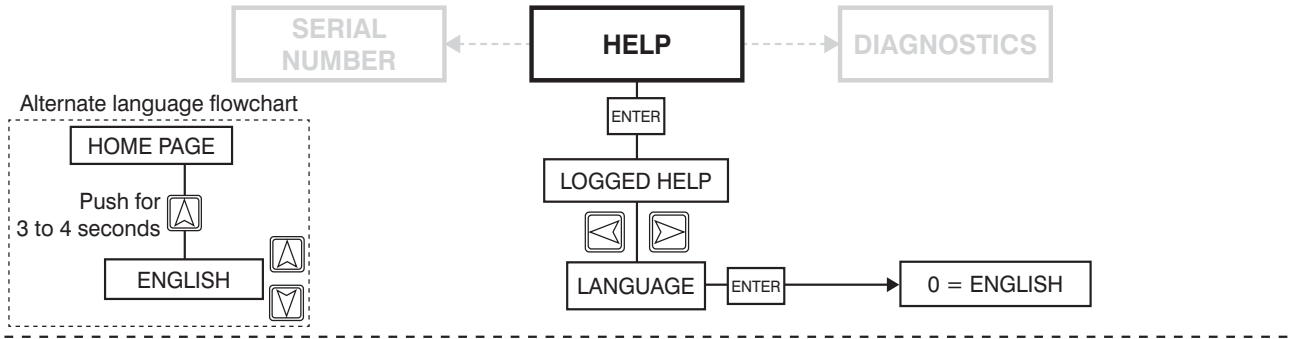

**Skycoded Controls - ACCESS LEVEL/SYSTEM OVERRIDE/RUN SYSTEM TEST**

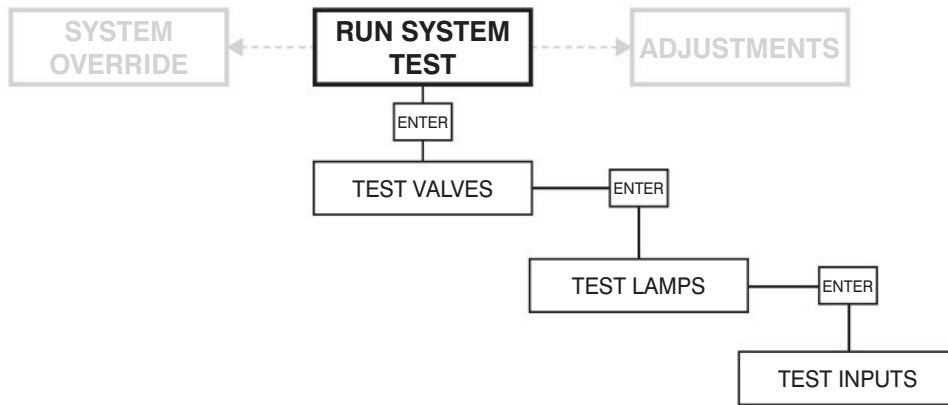
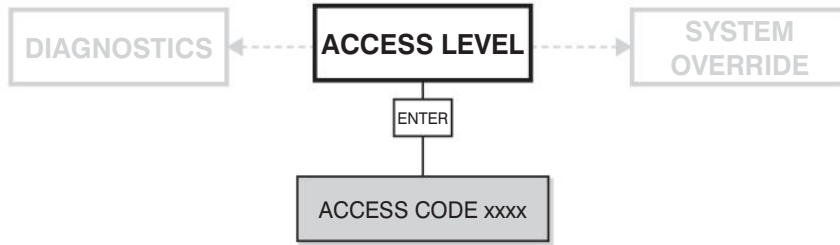

**Skycoded Controls - ADJUSTMENTS**

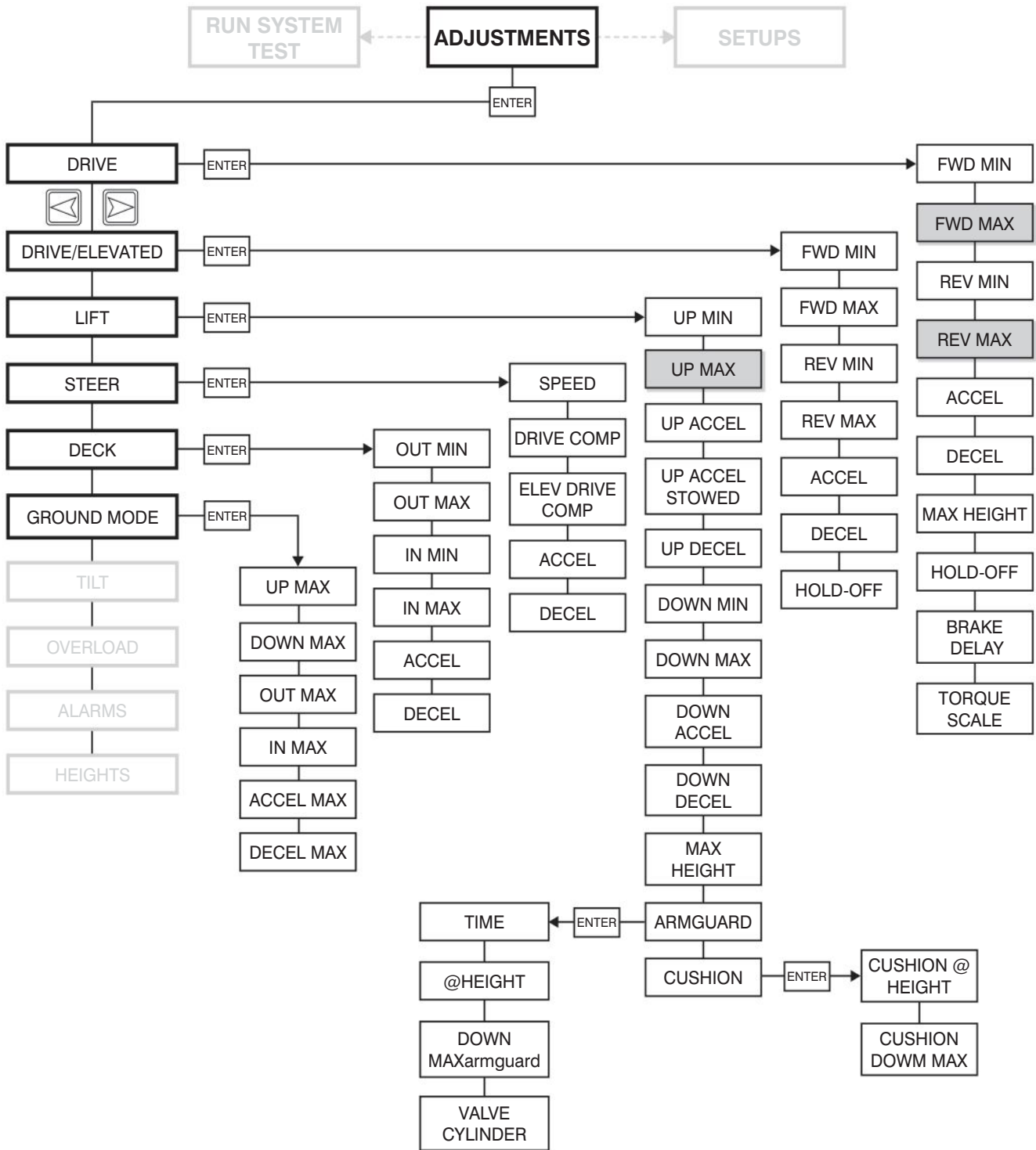



**Skycoded Controls - ADJUSTMENTS (Cont.)**

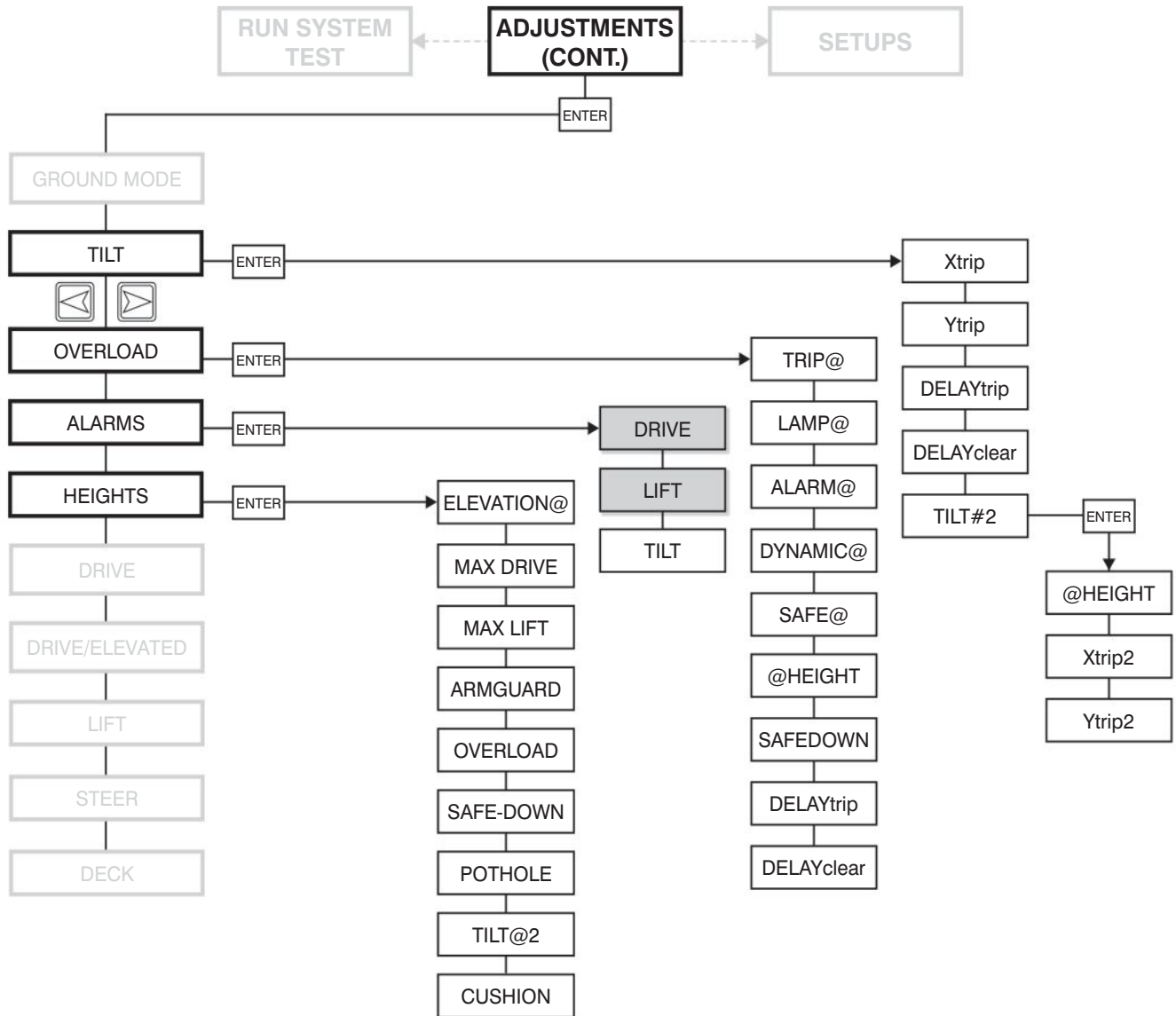

**Skycoded Controls - SETUPS**

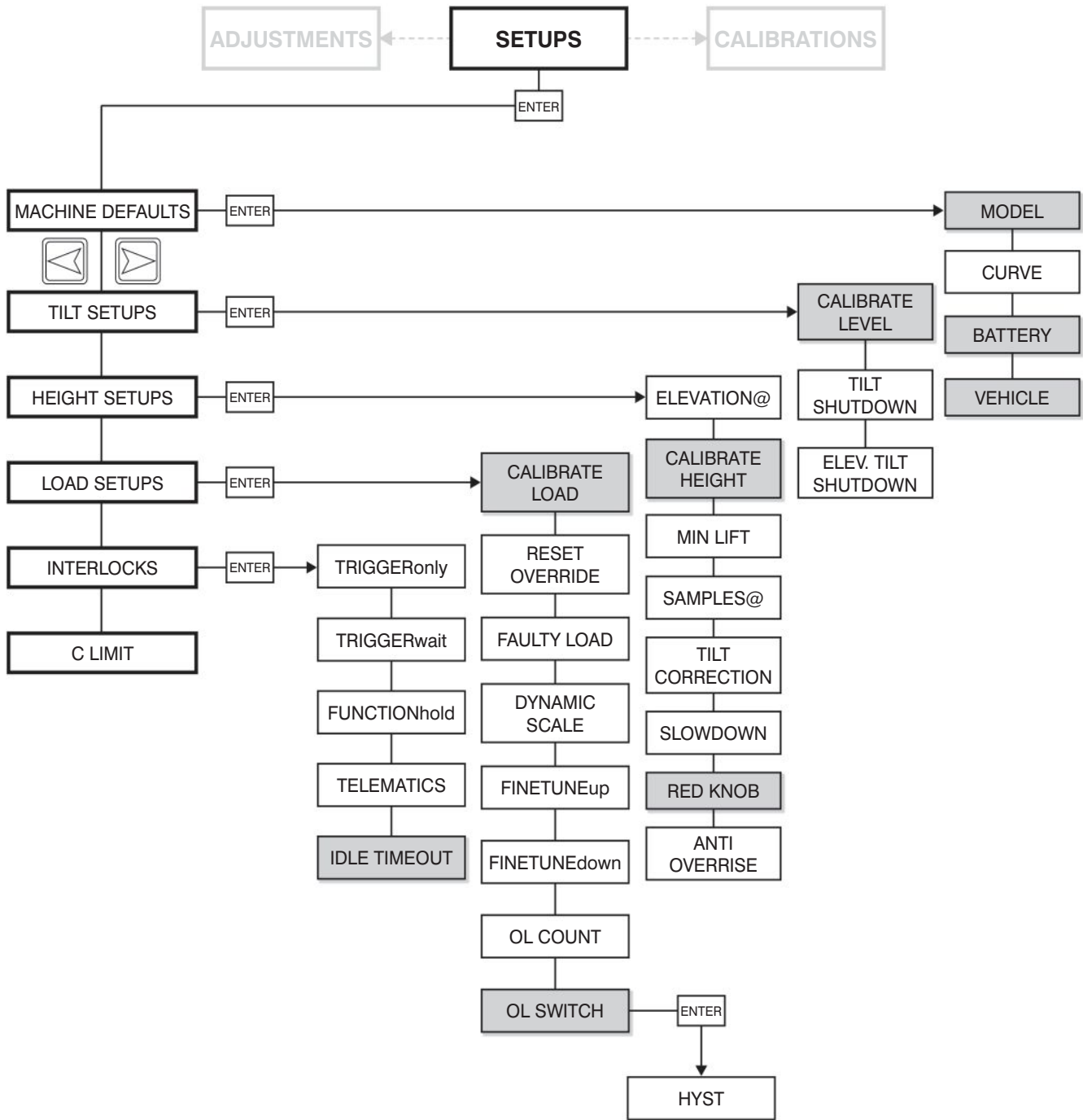

### Skycoded Controls - CALIBRATIONS/SERIAL NUMBER

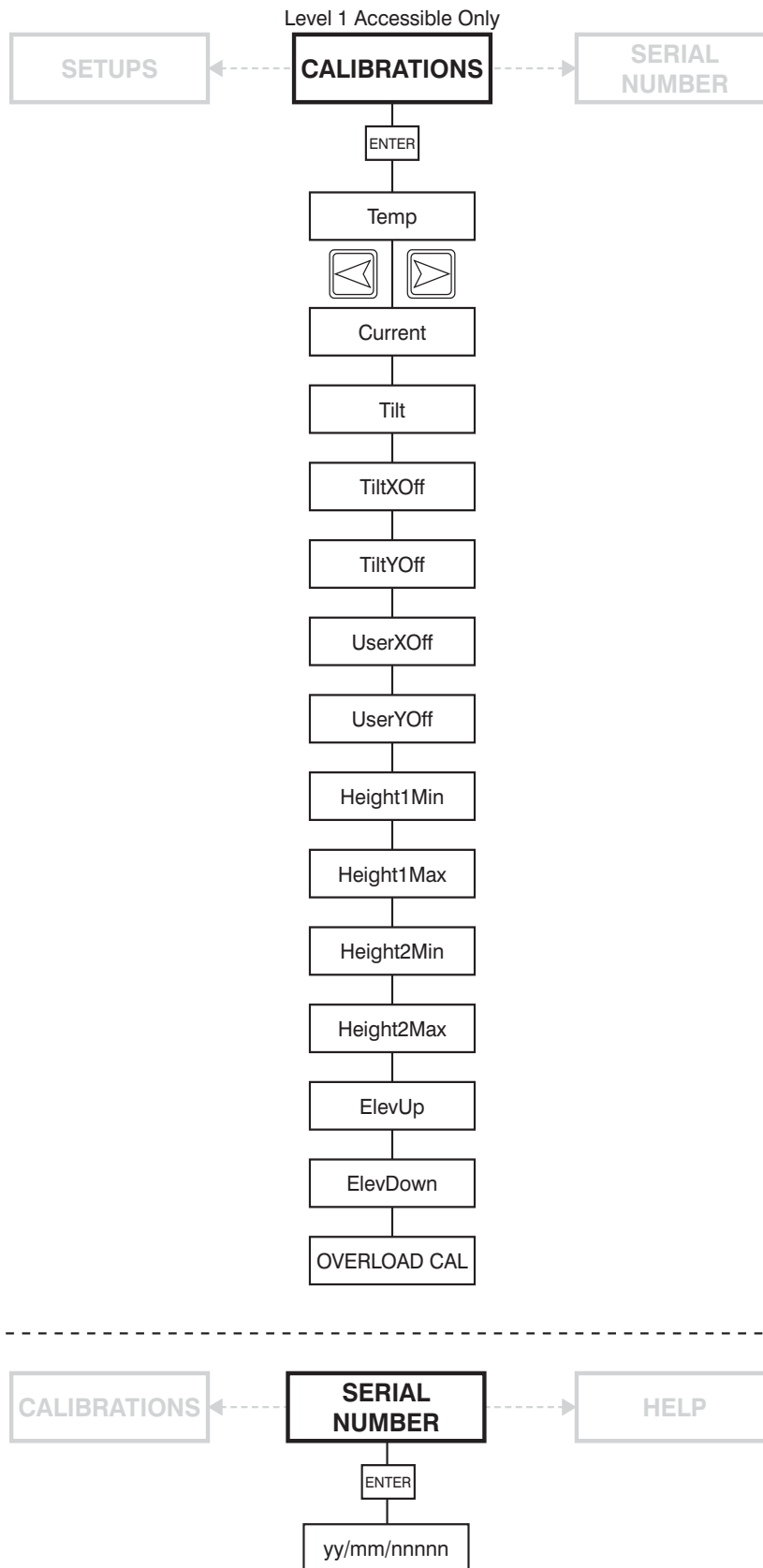

### Skycoded Control Module Menu Table

Items highlighted in grey requires technician access level 2 to change. Otherwise, menus are locked as initial factory access level 1.

Menu	Selection	Sub-Menu	Description
<b>HELP</b>			
LOGGED HELP	HELP		Press ENTER when viewing the current HELP message to see a log of recent HELP messages Press  to see older messages, and  to see newer ones Press ESC to return to the current HELP message
	LANGUAGE	0=ENGLISH	Press  or  select language preferred on the display
<b>DIAGNOSTICS</b>			
SYSTEM	MODE	OPERATING MODE	Displays current operating mode or interlock
		INTERLOCK	When current operating mode shows INTERLOCKED, press ENTER to see the reason for the interlock Press ESC to return to the current operating mode
	SUPPLY		Displays battery supply voltage
	VALVESUPPLY		Displays valve supply state
	MOTOR V		Displays motor voltage
	MOTOR I		Displays motor current
	TEMPERATURE		Displays temperature (°C)
	TILT		Displays tilt values (X°, Y°)
	TILTED		Displays whether system is in tilted mode (measured tilt exceeds tilt trip points)
	HEIGHT		Displays platform height, calculated from angle, pressure transducers and data stored during calibration. Angle transducers are installed, press ENTER when viewing the HEIGHT (which is the average of the two). To see the individual measurements of the two sensors, named HEIGHT1 and HEIGHT2 (press  and  to see both); press ESC to return to the average HEIGHT.
	LOAD		Displays Platform load (estimated from lift cylinder pressure measurement, platform height, and height/pressure curves stored during calibration).
	OVERLOADED		Displays whether system is in overload mode (Platform load exceeds load trip point, at/above overload height)
	LAST MOVED		Displays whether the most recent Platform movement was UP or DOWN; this is important if the lift cylinder pressure is affected by the direction of movement (during calibration, separate measurements are collected during lifting and lowering)
	ELEVATED		Displays whether system is in elevated mode
	AORcase		Displays Anti Over-Rise state
TELElock		Displays Telematics option	
PLATFORM	TRIGGER		Displays ON when Platform trigger pressed
	DLD		Displays drive / lift mode (from S3 Lift/Off/Drive switch)
	JOYSTICK		Displays joystick position (%)
	FWD/UP		Displays ON when joystick is moved toward FWD or UP
	REV/DOWN		Displays ON when joystick is moved toward REV or DOWN
	LEFT		Displays ON when steer left button pressed
	RIGHT		Displays ON when steer right button pressed
	POSITRAC		Displays ON when traction switch is pressed
EMSp		Displays ON, indicating Platform Emergency Stop circuit is active	

**Skycoded Control Module Menu Table (Continued)**

Menu	Selection	Sub-Menu	Description
GROUND	UP		Displays ON when UP switch pressed
	DOWN		Displays ON when DOWN switch pressed
	OUT		Displays ON when (optional) deck out switch pressed
	IN		Displays ON when (optional) deck in switch pressed
	EMSG		Displays ON, indicating ground Base Emergency Stop is active
INPUT	P3-1		Shows P3-1 input status (S10 Idle/PLTF/Base Key switch active)
	P3-2		Shows P3-2 input status (valve supply, on with Platform E-stop active)
	P3-3		Shows P3-3 input status (S27 Torque switch select high torque)
	P3-4		Shows P3-4 input status (S17 indoor/outdoor switch select indoor) (if equipped)
	P3-5		Shows P3-5 input status (S10 Idle/PTLF/Base Key switch select Base)
	P3-6		Shows P3-6 input status (S3 Lift/Off/Drive switch select Drive)
	P3-7		Shows P3-7 input status (S3 Lift/Off/Drive switch select Lift)
	P3-8		Shows P3-8 input status (S7-2 STEER RIGHT from joystick)
	P3-9		Shows P3-9 input status (S7-2 STEER LEFT from joystick)
	P3-10		Shows P3-10 input status (KC Anti Override N.O. signal)
	P3-11		Shows P3-11 input status (KC Anti Override N.C. signal)
	P3-12		Shows P3-12 input status (S7-6 Enable switch from joystick)
	P4-1		Shows P4-1 input status (S51 Emergency Lowering Toggle counter)
	P4-2		Shows P4-2 input status (not used)
	P4-3		Shows P4-3 input status (not used)
	P4-4		Shows P4-4 input status (S2 Lift/Lower Toggle switch DOWN select)
	P4-5		Shows P4-5 input status (S2 Lift/Lower Toggle switch UP select)
	P4-6		Shows P4-6 input status (not used)
	P4-7		Shows P4-7 input status (LS1 & LS2 Pothole Protection limit sw's active)
	P4-8		Shows P4-8 input status (powerdeck extended) (if equipped)
	P4-9		Shows P4-9 input status (powerdeck retracted) (if equipped)
	P4-10		Shows P4-10 input status (charger cutout interlock switch)
	P4-11		Shows P4-11 input status (not used)
P4-12		Shows P4-12 input status (not used)	
	JOYSTICK INPUTS		Shows Joystick M3 input status CANBus (not used)
ANALOGS	P1-2		Displays voltage measurement of joystick analog input P1-2
	P1-4		Displays Trackunit Telematics option (if equipped)
	P2-2		Displays voltage measurement of AT1 Angle Transducer analog input P2-2 signal
	P2-4		Displays voltage measurement of PT1 Pressure Transducer analog P2-4 signal
	P2-5		Displays voltage measurement of AT Angle Transducer analog input P2-5 signal

**Skycoded Control Module Menu Table (Continued)**

Menu	Selection	Sub-Menu	Description	
ANALOGS (CONT.)	P2-6		Not used	
	JOYSTICK ANALOGS		Displays Joystick M2 CANBus signals (not used)	
OUTPUTS	PUMPMODE		Displays state of Pumpmode setting	
	P1-5		Displays state of P1-5 CANbus High signal (if equipped)	
	P1-6		Displays state of P1-6 CANbus Low signal (if equipped)	
	P1-7		Displays state of P1-7 output (not used)	
	P1-8		Displays state of P1-8 output (PL-1 & PL-2 Overload lamp)	
	P1-9		Displays state of P1-9 output (BP-29 All-Motion, Tilt and Overload Beeper)	
	P2-9		Displays state of P2-9 output (FL-22 Flashing Light)	
	P5-1		Displays state of P5-1 output (C1 Motor Contactor)	
	P5-2		Displays state of P5-2 output (Forward Drive)	
	P5-3		Displays state of P5-3 output (Reverse Drive)	
	P5-4		Displays state of P5-4 output (Brake release)	
	P5-5		Displays state of P5-5 output (Lift UP)	
	P5-6		Displays state of P5-6 output (Steer Left)	
	P5-7		Displays state of P5-7 output (deck extend) (if equipped)	
	P5-8		Displays state of P5-8 output (Steer Right)	
	P5-9		Displays state of P5-9 output (Torque Mode high speed select)	
	P5-10		Displays state of P5-10 output (deck retract) (if equipped)	
	P5-11		Displays state of P5-11 output (lower valve) (CE only)	
	P5-12		Displays state of P5-12 output (Holding Valves)	
	FEEDBACK			Press ENTER to display this sub-menu to view feedback status of outputs
		P5-1		Displays P5-1 (C1 Motor Contactor) output status – LO when off, HI when on
P5-x			Displays output status of all other P5 outputs (except P5-1 above) (ie: valves) – LO when all valves off, HI when any valve on	
JOYSTICK OUTPUTS		Displays output status of Joystick M1 CANBus signals (not used)		
LOG	CALDATE		Displays date entered by operator at end of last calibration	
	SOFTWARE		Displays software version of Control Module CM1	
	POWERED		Displays total time that Control Module CM1 has been powered	
	MAX.BATTERY		Displays maximum recorded battery supply voltage	
	WORKTIME		Displays total time that the pump has been powered	

**Skycoded Control Module Menu Table (Continued)**

Menu	Selection	Sub-Menu	Description
<b>ACCESS LEVEL</b>			
	CODE xxxx		<p>ACCESS LEVEL" 3 prevents adjustments and calibrations (default)</p> <p>ACCESS LEVEL" 2 allows calibrations (requires correct code)</p> <p>"ACCESS LEVEL" 1 allows adjustments and calibrations (factory level)</p> <p>"PUMPMODE" allows troubleshooting without Hydraulic pump function</p> <p>When the Display Module is connected and powered on, the initial "ACCESS LEVEL" level 3 by default and adjustments cannot be altered and calibrations cannot be carried out.</p> <p>Before Calibrations can be done, the "ACCESS LEVEL" must be changed to level 2 using the correct access code. ACCESS LEVEL 2 allows calibrations and allows some adjustments to be changed.</p> <p>Adjustments should only be attempted by qualified individuals.</p>
<b>SYSTEM OVERRIDE*</b>			
			Press ENTER to ENTER into OVERRIDE mode.
<b>RUN SYSTEM TEST</b>			
	TEST VALVES		Press ENTER to run rolling test of all valves coils on at a time. Coils will be energized in a rolling pattern. Any short circuits or incorrect feedback will be displayed. Press ESC to skip to the next test.
	TEST LAMPS		Press ENTER to run rolling test of all lamps, Press ESC to skip to the next test
	TEST INPUTS		Press ENTER to run a rolling test of all inputs. This requires the tester to manually operate the switches when requested. Press ESC to skip to the next test.
<b>ADJUSTMENTS (Access level 1 required unless highlighted in grey)</b>			
DRIVE	FWD MIN		Determines the slowest drive speed in the forward direction (when the joystick is at 0% demand)
	FWD MAX		Determines the fastest drive speed in the forward direction (when the joystick is at 100% demand)
	REV MIN		Determines the slowest drive speed in the reverse direction (when the joystick is at 0% demand)
	REV MAX		Determines the fastest drive speed in the reverse direction (when the joystick is at 100% demand)
	ACCEL		Determines the rate of increase of drive speed when higher speeds are demanded
	DECEL		Determines the rate of decrease of drive speed when lower speeds (or stop) are demanded
	MAX HEIGHT		Determines the height above which drive is prevented.
	HOLD-OFF		Sets a delay time to keep drive valve turned on after ramping to a stop (if needed to avoid locking wheels at stop)
	BRAKE DELAY		Sets a delay time for when the brakes are activated
	TORQUE SCALE		Sets the torque scale
DRIVE/ELEVATED	FWD MIN		Determines the slowest drive speed in the forward direction (when the joystick is at 0% demand) when elevated
	FWD MAX		Determines the fastest drive speed in the forward direction (when the joystick is at 100% demand) when elevated
	REV MIN		Determines the slowest drive speed in the reverse direction (when the joystick is at 0% demand) when elevated
	REV MAX		Determines the fastest drive speed in the reverse direction (when the joystick is at 100% demand) when elevated
	ACCEL		Determines the rate of increase of drive speed when higher speeds are demanded when elevated
	DECEL		Determines the rate of decrease of drive speed when lower speeds (or stop) are demanded when elevated
	HOLD-OFF		Sets a delay time to keep drive valve turned on after ramping to a stop when elevated
LIFT	UP MIN		Determines the slowest lifting speed (when the joystick is at 0% demand)
	UP MAX		Determines the fastest lifting speed (when the joystick is at 100% demand)

 Items highlighted in grey requires access level 2.

**Skycoded Control Module Menu Table (Continued)**

Menu	Selection	Sub-Menu	Description	
LIFT (CONT.)	UP ACCEL		Determines the time for acceleration of lifting	
	UP ACCEL STOWED		Determines the time for acceleration from stowed	
	UP DECEL		Determines the time for deceleration	
	DOWN MIN		Determines the slowest lowering speed (when the joystick is at 0% demand)	
	DOWN MAX		Determines the fastest lowering speed (when the joystick is at 100% demand)	
	DOWN ACCEL		Determines the rate of increase of lift speed when higher speeds are demanded as well as lowering speed, if lowering is controlled by the pump or a proportional valve.	
	DOWN DECEL		Determines the rate of decrease of lift speed when lower speeds are demanded as well as lowering speed, if lowering is controlled by the pump or a proportional valve.	
	MAX HEIGHT		Determines the height above which lifting is prevented.	
	ARMGUARD			Press ENTER to display sub-menu to access adjustments related to armguard
		TIME		Determines the time delay when armguard triggers during lowering, before lowering is allowed to continue
		@HEIGHT		Determines the height at which "soft armguard" occurs when lowering
		DOWN MAXarmguard		Determines the speed at which "soft armguard" occurs when lowering
		VALVE CYLINDER		Determines the location of the Proportional Valve (Main manifold or Cylinder)
	CUSHION@	CUSHION @ HEIGHT		Determines the height at which the cushion occurs
CUSHION DOWN MAX			Determines the speed at which the cushion is enabled	
STEER	SPEED		Determines the pump speed when steering is used on its own (without drive).	
	DRIVE COMP		Determines the additional speed to apply to the current drive speed when steering is used when driving while the platform is not elevated – it can be adjusted to minimize any slow down in drive speed due to steering demand.	
	ELEV DRIVE COMP		Determines the additional speed to apply to the current drive speed when steering is used when driving while elevated.	
	ACCEL		Determines the rate of increase of pump speed when steering is selected on its own (without drive)	
	DECEL		Determines the rate of decrease of drive speed when steering is selected on its own (without drive)	
DECK	OUT MIN		Determines the slowest deck out (extend) speed (when the joystick is at 0% demand)	
	OUT MAX		Determines the fastest deck out (extend) speed (when the joystick is at 100% demand)	
	IN MIN		Determines the slowest deck in (retract) speed (when the joystick is at 0% demand)	
	IN MAX		Determines the fastest deck in (retract) speed (when the joystick is at 100% demand)	
	ACCEL		Determines the rate of increase of deck speed when higher speeds are demanded	
	DECEL		Determines the rate of decrease of deck speed when lower speeds are demanded	
GROUNDMODE	UP		Determines the (fixed) lifting speed in Base mode	
	DOWN		Determines the (fixed) lowering speed in Base mode	
	OUT		Determines the (fixed) deck out (extend) speed in Base mode	
	IN		Determines the (fixed) deck in (retract) speed in Base mode	
	ACCEL		Determines the rate of increase of lift/lower/deck speeds in Base mode	
	DECEL		Determines the rate of decrease of lift/lower/deck speeds in Base mode	



**Skycoded Control Module Menu Table (Continued)**

Menu	Selection	Sub-Menu	Description	
TILT	Xtrip		Determines the amount of machine tilt needed to trigger the “tilted” condition; separate adjustments are provided for tilt in the two axis – the Control Module correctly combines tilt in each axis to determine an overall tilted/not-tilted condition.	
	Ytrip			
	DELAYtrip		Determines the time delay (“debounce”) to go from not-tilted to tilted, and from tilted to not-tilted – “DELAYtrip” determines the time delay to go in to a “tilted” condition and “DELAYclear” determines the time delay to exit the “tilted” condition.	
	DELAYclear			
	TILT#2			Press ENTER to display sub-menu to access adjustments related to second tilt trip points
		@HEIGHT		Determines the height above which second tilt trip points apply.
		Xtrip2		Determines the amount of machine tilt needed to trigger the “tilted” condition, when above the second tilt height. The same DELAY settings are used as for the normal tilt trip points.
Ytrip2				
OVERLOAD	TRIP@		Determines the Platform load estimate above which functions will be prevented. NOTE: Each machine must be calibrated with the Platform fully loaded and also empty before the platform load estimates can be made.	
	LAMP@		Determines the Platform load estimate above which the overload warning lamp will be active.	
	ALARM@		Determines the Platform load estimate above which the overload warning alarm will be active.	
	DYNAMIC		Determines the Platform load estimate when moving and not static.	
	SAFE@		Determines the Platform percentage of load which functions will be allowed.	
	@HEIGHT		Determines the height above which an overloaded Platform will prevent functions.	
	SAFE-DOWN		Determines the height below which an overloaded Platform can still be lowered – this is because when the platform is fully lowered, overload cannot be determined since there is no load on the lift cylinder; instead the first overload is determined according to @HEIGHT, and if the platform is overloaded, it must be able to be lowered again so the operator can reduce the weight.	
	DELAYtrip		Determines the time delay (“debounce”) to go from not-overloaded to overloaded, and from overloaded to not-overloaded. DELAYtrip determines the time delay to go in to an “overloaded” condition. DELAYclear determines the time delay to exit the “overloaded” condition.	
DELAYclear				
ALARMS	DRIVE		Determines when to sound the alarm – set to “NO” to not sound while driving, to “FWD” or “REV” to sound while driving in that direction, or to “BOTH” to sound for driving in either direction.	
	LIFT		Determines when to sound the alarm – set to “NO” to not sound while lifting/lowering, to “UP” or “DOWN” to sound while lifting or lowering, or to “BOTH” to sound for lifting and lowering.	
	TILT		Determines when to sound the alarm – set to “NO” to not sound depending on tilt, to “ELEVATED” to sound if tilted and elevated, or to “ALWAYS” to sound when tilted irrespective of platform height.	
HEIGHTS	ELEVATION@		Determines the “elevation” point – the Platform height at which the machine is considered to be elevated.	
	MAX DRIVE		Determines the height above which drive is prevented.	
	MAX LIFT		Determines the height above which lift is prevented.	
	ARMGUARD		Determines the height at which “soft armguard” occurs when lowering.	
	OVERLOAD		Determines the height above which an overloaded platform will prevent functions.	
	SAFE-DOWN		Determines the height below which an overloaded platform can still be lowered.	
	POTHOLE		Determines the height at which the Pothole bar is engaged.	
	TILT#2		Determines the height above which reduced overload trip points apply.	
CUSHION		Determines the height at which the cushioning effect is applied.		

 Items highlighted in grey requires access level 2.

**Skycoded Control Module Menu Table (Continued)**

Menu	Selection	Sub-Menu	Description
<b>SETUPS</b>			
MACHINE DEFAULTS	See <a href="#">5.4-5 Initial Set-up and Change Defaults Procedure</a>		
	MODEL		Factory set to configure machine type; confirm that the correct customer code is displayed. Determines the initial default settings of all ADJUSTMENTS; Set to change to the correct model code for the machine.
	CURVE		Selects the proper preprogrammed load/height curve.
	BATTERY		Selects the type of battery installed in machine.
	VEHICLE		Selects the type of vehicle.
TILT SETUPS	See <a href="#">5.4-7 Calibrate Level Procedure</a>		
	CALIBRATE LEVEL		Calibrates Control Module CM1 tilt to zero degrees X and Y.
	TILT SHUTDOWN		Determines if Control Module CM1 will prevent functions when machine is tilted: NEVER – no functions prevented LIFT&DRIVE – lifting and driving prevented (lowering still allowed) LIFT – lifting prevented (lowering and driving still allowed) DRIVE – driving prevented (lifting and lowering still allowed)
	ELEV. TILT SHUTDOWN		Determines if Control Module CM1 will prevent functions when machine is both tilted and elevated.
HEIGHT SETUPS	ELEVATION@		Determines the “elevation” point – the platform height at which the machine is considered to be elevated.
	CALIBRATE HEIGHT		Calibrates platform height from 0% to 100%.
	MIN LIFT		Determines the minimum time between each static measurement during load calibration.
	SAMPLES@		Determines the time between samples during dynamic lifting load calibration.
	TILT CORRECTION		Configures how to correct machine tilt so that Control Module CM1 height measurement is correct.
	SLOWDOWN		Determines whether to reduce lifting speed as platform height approaches MAX LIFT setting or not to make sure there is no overshoot.
	RED KNOB		Determines if machine was built with the “red knob” manual override in the Holding Valves for emergency lowering.
	ANTI OVERRIDE		Determines if the machine has optional KC Anti Overriding switches. 1=disable, 2=enable.
LOAD SETUPS	See <a href="#">5.4-8 Calibrate Load Procedure</a>		
	CALIBRATE LOAD		Calibrates platform load estimation from 0% to 100% height, at rated load and empty, as measured by the lift cylinder pressure sensor.
	RESET OVERRIDE		Determines if the count for Override function can be reset to zero.
	FAULTY LOAD		Determines whether to prevent movement if load estimate is implausibly low (i.e. damaged pressure sensor).
	DYNAMIC SCALE		Determines sensitivity to stop at OVERLOAD @HEIGHT, if platform load estimate is close to trip point.
	FINETUNEup		Determines the percentage of fine tuning calculated during Calibration for UP movement.
	FINETUNE down		Determines the percentage of fine tuning calculated during Calibration for DOWN movement.
	OL COUNT		HIDE or SHOW the count for Overload triggers made.(CE models only).
OL SWITCH	HYST	Determines the version of Overload switches (CE model only).	
INTERLOCKS	TRIGGERonly		Determines whether or not to trigger an interlock when the trigger is closed with no other function select and after what delay to do it in.
	TRIGGERwait		Determines whether or not to trigger an interlock when a function is selected without the trigger being closed and after what delay to do it in.

  Items highlighted in grey requires access level 2.

**Skycoded Control Module Menu Table (Continued)**

Menu	Selection	Sub-Menu	Description
INTERLOCKS (CONT.)	FUNCTIONhold		Only applicable if drive/lift mode is selected with momentary push switches; when using a drive/lift toggle switch.
	TELEMATICS		Determines if the Telematics option is "Normal" or has a "Lockout" keypad option installed.
	IDLE TIMEOUT		Determines time until Control Module CM1 goes into sleep mode if no functions or operations have been requested for that time.
	C LIMIT		Determines the Current Limit of the motor before being derated. Set below the fuse amperage.
<b>CALIBRATIONS (Access Level 1 required)</b>			
	Temp		Factory set to calibrate heatsink temperature (motor power may be reduced if the heatsink temperature is too high).
	Current		Factory set to calibrate motor current.
	TiltGain		Factory set to calibrate Control Module CM1 tilt sensor.
	TiltXoff		
	TiltYoff		
	UserXoff		Set when the "CALIBRATE LEVEL" procedure is carried out, to correct for slight tilt offset due to mounting of the Control Module CM1 to machine chassis, and chassis to ground.
	UserYoff		
	Height1Min		Set when the "CALIBRATE HEIGHT" (or "CALIBRATE LOAD" dynamic) procedure is carried out, to determine the Angle Transducers measurements when the platform is fully lowered (0% height) and fully raised (100% height).
	Height1Max		
	Height2Min		
	Height2Max		
	ElevUp		Set when the "CALIBRATE HEIGHT" (or "CALIBRATE LOAD" dynamic) procedure is carried out, to determine the platform height.
	ElevDown		
	OVERLOAD CALS		This sub-menu provides access to the load calibration data created during the "CALIBRATE LOAD" loaded & empty procedure.
<b>SERIAL NUMBER (Access level 2 required)</b>			
	yy/mm/nnnnn		Displays the Control Module CM1 serial number

Items highlighted in grey requires access level 2.

### 5.4-3 Diagnostics, Help Messages and Flash Codes

#### Diagnostics

The display module shows the machine condition and operating information during operation.

Message	Description
INITIALIZING	Preparing to operate, immediately after power-on
SHUTDOWN	All operation prevented – for example both the PLATFORM & BASE Emergency Stops inputs are active together
CHECK CANbus	All operation prevented – CANbus communications is not successful
PLATFORM, GROUND	Ready to operate, from the Platform or Base controls as indicated (selected by the two Emergency Stop inputs)
GROUND UP, GROUND DOWN, GROUND OUT, GROUND IN	A Base function is operating normally
GROUND UP LOCKED, GROUND DOWN LOCKED, GROUND OUT LOCKED, GROUND IN LOCKED	A Base function is selected but not allowed (for example, the switch was closed at power-on)
GROUND FAULTY	Multiple ground function inputs are active at the same time
WAITING FOR TRIGGER	A Platform function is selected, but the trigger Enable switch is not closed (close trigger switch to proceed)
TRIGGER CLOSED	The Platform trigger Enable switch is closed, but no function is selected (select a function to proceed)
TRIGGER LOCKED	The Platform trigger Enable switch was closed at power-on, or closed for too long with no function selected
FORWARD, REVERSE	A Platform drive function is operating normally
FORWARD (LEFT), FORWARD (RIGHT), REVERSE (LEFT), REVERSE (RIGHT)	A Platform drive function is operating normally, with steer also active
STEER LEFT, STEER RIGHT	A Platform steer function is operating normally (without drive)
UP, DOWN	A Platform lift/lower function is operating normally
OUT, IN	A Platform deck extend/retract function is operating normally
FORWARD LOCKED, REVERSE LOCKED	A Platform drive function is selected but not allowed (for example, the switch was closed at power-on)
POTHOLE -DRIVE LOCKED	The Pothole Protection switches have not engaged when raised Platform
LEFT LOCKED, RIGHT LOCKED	A Platform steer function is selected but not allowed (for example, the switch was closed at power-on)
CHECK JOYSTICK	Both Platform joystick directions are active at the same time
STEER FAULTY	Both Platform steer directions are active at the same time
INTERLOCKED	An interlock shutdown is active, preventing one or more functions. The interlock can be due to many different causes – press <ENTER> from the display to see the precise cause of the interlock (listed below) – press <ESC> from that display to return to the MODE display:

**Diagnostics (Continued)**

Message	Description
INTERLOCKED	An interlock shutdown is active, preventing one or more functions. The interlock can be due to many different causes – press <ENTER> from the display to see the precise cause of the interlock (listed below) – press <ESC> from that display to return to the MODE display:
<ul style="list-style-type: none"> <li>• ARMGUARD</li> </ul>	"During descent, the Control Module CM1 can be configured to stop movement and provide an armguard delay (allowing time to check that everything is clear before continuing descent) Release and re-select DOWN to continue lowering (after the delay time has passed) If the armguard feature is not wanted,"
<ul style="list-style-type: none"> <li>• EXTERNAL ALL, EXTERNAL DRIVE, EXTERNAL LIFT</li> </ul>	An external cutout input is preventing functions – determine the cause of the external cutout
<ul style="list-style-type: none"> <li>• NONE</li> </ul>	There is no interlock (the interlock has cleared while viewing the display)
<ul style="list-style-type: none"> <li>• OVERLOADED</li> </ul>	The Platform is overloaded – reduce platform load
<ul style="list-style-type: none"> <li>• TEST MODE</li> </ul>	The Control Module CM1 test mode is active – switch power off and on again to clear
<ul style="list-style-type: none"> <li>• TILTED</li> </ul>	"The machine is tilted beyond limits, with the Control Module CM1 configured to prevent some functions when tilted (perhaps also elevated) – descend, then move machine to a more level location (see SETUPS/TILT SETUPS/TILT SHUTDOWN and ELEV.TILT SHUTDOWN)"
<ul style="list-style-type: none"> <li>• TOO HIGH</li> </ul>	"The platform is too high to allow some functions – descend first (see ADJUSTMENTS/HEIGHTS/MAX DRIVE and MAX LIFT)"
<ul style="list-style-type: none"> <li>• TOO HOT</li> </ul>	"The Control Module CM1 heatsink has reached 75°C, preventing all functions except lowering. Functions will be allowed again when the heatsink cools to below 70°C. The heatsink temperature can be viewed in the DIAGNOSTICS/SYSTEM/TEMPERATURE display."
<ul style="list-style-type: none"> <li>• UNCALIBRATED</li> </ul>	"The height and/or pressure sensors have not been calibrated and are required to measure platform height and/or load If overload functions are active (ADJUSTMENTS/OVERLOAD TRIP@, LAMP@ or ALARM@ set to a non-zero value) then both the height and pressure sensors must be calibrated If overload functions are not active, but height-based decisions are active (ADJUSTMENTS/ HEIGHT values set to between 1% and 100%) then the height sensors must be calibrated Calibration procedures are accessible from the SETUPS/HEIGHT SETUPS and SETUPS/LOAD SETUPS menus"

**Help Messages**

The display module shows help messages to show the machine conditions. Some messages cause the LED on the control module to flash so you can still do simple troubleshooting even if the display is not working.

**IMPORTANT**

**Skyjack recommends reading the diagnostic messages from the display module and not the LED flash codes to troubleshoot the machine. The diagnostic messages give more detailed data.**

**LED Flash Codes**

The diagnostic messages from the LED are shown as Dual Flash Codes. The LED flashes on/off a number of times, stay off for a short time, then flash on/off a number of times again then followed by a much longer off time. The sequence repeats.

For example, on/off/on/off/on/off-short-delay/on/off/on/off-long-delay/repeat

Flash Code	Description
LED on steady	There is no fault. All functions should be working normally.
LED off always	There is no power to the Control Module CM1. Check wiring to P3-1 and P4-1
LED flash code 1/x	The Control Module CM1 has not been properly calibrated. Check height and load calibration.
LED flash code 2/x	<p>Something is preventing functions operating normally. check EMS inputs and all operator switch inputs (drive/lift mode, joystick, etc). Check for conditions which shut down functions (eg: tilted, too high to drive, platform overloaded, etc).</p> <p>NOTE: In base mode, only the base input switches are relevant. In platform mode the base input switches are ignored.</p>
LED flash code 3/x	<p>There is a problem with the line contactor or valve wiring, or with the motor power wiring. Disconnect connector P5 to see if the problem is caused by line contactor or valve wiring (if the fault clears, check for an illegal B+ supply in to P5).</p> <p>Check the motor power wiring. With the line contactor open, power terminals B+ and A should both be at 10V-15V (significantly lower than B+).</p> <p>If the LED is steady at power-on, and the fault (3/5) occurs after a delay when attempting to drive or lift, the motor may be stalled and causing an overload of the Control Module CM1.</p>
LED flash code 4/x	<p>There is a problem with battery supply, the height and/or pressure sensors, the supply to them, or the temperature sensor inside the Control Module CM1.</p> <p>Check battery supply to EMS inputs P3-1 or P4-1 (relative to the B- stud). The battery supply should be between 15V and 32V.</p> <p>Check the output from height and pressure sensors (P2/2, P2/4, P2-5). Check the 5V sensor supply (P2-1)</p> <p>If the Control Module CM1 heatsink is very hot then the controller has temporarily shut down – if so, platform lowering is still allowed. Wait for the controller to cool down.</p>
LED flash code 6/x	<p>There is a problem with load measurement – the height and/or pressure sensor measurements are out of range or the elevation switch disagrees with the height sensor.</p> <p>Check that the output from height and pressure sensors (P2/2, P2/4, P2-5) is in range (between 0.5V and 4.5V),</p>
LED flash code 7/x	There is a problem with the power wiring – the voltage on the B+ stud is too low (it should be at least 10V at all times). Check for a short-circuit to the B+ stud.
LED flashing fast and continuously	<p>This indicates that “factory override” is active – this special controller mode is intended for use during machine manufacture only (see OVERRIDE procedure)</p> <p><b>IMPORTANT: Never use a machine that is still in “factory override” – all safety and shutdown features are disabled!</b></p>

**Help Messages and Fault Codes**

Code	Message	Description	Flash Code
101	21510202 MENU	This is the part number of the Control Module CM1.	N/A
102	ACTIVE		N/A
103	CHARGING		N/A
104	CHECK DRIVE/LIFT SELECT SWITCH!	There is a problem with the platform drive/lift select switch – both modes are selected together.	2/2
105	CHECK GROUND INPUT SWITCHES!	There is a problem with the Base function select switches – more than one is active at the same time.	2/2
106	CHECK JOYSTICK SWITCHES!	There is a problem with the platform joystick switches – both directions are selected together.	2/2
107	CHECK RED KNOB	There is a problem with the red “manual holding valve” knob (if equipped).	N/A
108	CLOSE TRIGGER	A Platform function is selected but the trigger switch is not closed.	N/A
109	DRIVE LOCKED - POTHOLE!	The Pothole Limit switch(es) are tripped. Check limit switch(es) at P4-7.	N/A
110	DRIVING!		N/A
111	ENTER PINPAD CODE	Telematics input code required to unlock.	N/A
112	EVERYTHING OK	The Control Module CM1 is ready to operate in Platform mode when a function is selected. NOTE: If this is the HELP message when a function is selected, check for open-circuit switches or wiring.	N/A
113	EXTENDING DECK!		N/A
114	FACTORY OVERRIDE	When the controller is first shipped, prior to initial calibration, it is configured in a special “factory override” state. In this state, none of the normal shutdowns or interlocks will occur – the MEWP can be freely raised/lowered and driven irrespective of any calibration needs, tilt, etc. IMPORTANT: Never use a machine in factory override. This state is ONLY intended for use during manufacture! While factory override is active, the LED rapidly flashes on/off.	Fast Flashing
115	FAULT: B+ STUD VOLTAGE TOO HIGH - CHECK LINE CONT!	The voltage on the B+ stud of the controller (connected to an internal voltage stabilization capacitor bank) is close to B+ when the line contactor is off. Check the line contactor tips are not welded; check the power wiring for errors.	3/3
116	FAULT: B+ STUD VOLTAGE TOO LOW!	The voltage on the B+ stud of the controller (connected to an internal voltage stabilization capacitor bank) is too far from B+ when the line contactor is off (a pre-charge circuit in the module normally applies a voltage to the capacitor bank).	7/7
117	FAULT: BAD 5V SENSOR SUPPLY - CHECK P2-1 WIRING!	Check the power wiring for errors.	4/5
118	FAULT: BAD INTERNAL 12V!	The internal “12V” supply is out of range; if the fault remains, the controller may have to be replaced.	4/3
119	FAULT: BAD INTERNAL 5V!	The internal “5V slave” supply is out of range; if the fault remains, the controller may have to be replaced.	4/2
120	FAULT: BAD INTERNAL SLAVE!	The internal “slave” is not operating correctly; if the fault remains, the controller may have to be replaced.	4/2



**Help Messages and Fault Codes (Continued)**

Code	Message	Description	Flash Code
121	FAULT: BAD INTERNAL TEMPERATURE SENSOR!	The heatsink temperature is out of range. If the fault remains, the power controller may have to be replaced.	4/1
122	FAULT: BATTERY VOLTAGE TOO HIGH!	The battery supply is too high – check that the correct battery and charger are installed.	4/4
123	FAULT: BATTERY VOLTAGE TOO LOW!	The battery supply is too low – the battery must be re-charged.	4/4
124	FAULT: CAN BUS!	CANbus messages expected from one or more modules are not being received, or messages intended to one or more module cannot be transmitted. Check for open- and short- circuit problems with the CANbus wiring. Make sure that the CANbus is wired correctly pin-to-pin. Make sure that the machine chassis is not incorrectly shorted to the motor wiring (for example, due to insulator breakdown in the motor).	6/6
125	FAULT: CHECK ELEVATION SWITCH	This message does not apply to this machine. If this message shows on the Skycoded display, make sure the machine is calibrated correctly. If the message continues, contact the Skyjack service department.	6/3
126	FAULT: CHECK HEIGHT SENSORS	The two height transducer outputs should read the same height at all times; this message indicates that they are reading different heights. Check for loose wiring and check transducer outputs, or the transducer may need to be replaced.	6/1
127	FAULT: CHECK HEIGHT1 SENSOR	A height sensor is giving an out-of-range voltage (below 0.5V or above 4.5V). Check for open- or short-circuit wiring; replace height sensor if necessary.	6/1
128	FAULT: CHECK HEIGHT2 SENSOR		6/1
129	FAULT: CHECK PRESSURE SENSOR	The pressure sensor is giving an out-of-range voltage (below 0.5V or above 4.5V). Check for open- or short- circuit wiring. Replace pressure sensor and re-calibrate load if necessary.	6/2
130	FAULT: CUSTOMER	The Control Module CM1 must be configured to the customer requirements – this should have been done before the controller was shipped from factory.	1/1
131	FAULT: ENERGIZED LINE CONTACTOR - CHECK P5 WIRING!	There is a voltage on the line contactor coil output when it should be off. Check wiring to line contactor coil.	3/4
132	FAULT: ENERGIZED VALVE - CHECK P5 WIRING!	There is a line voltage on a valve output from coils wired to P5. Check for a short circuit or illegal wiring.	3/2
133	FAULT: MOTOR OVERLOAD!	The Control Module CM1 power protection circuits have activated to protect from extreme overload. Check for short-circuit power wiring. Check for a seized motor.	3/5
134	FAULT: VALVE FEEDBACK HIGH - CHECK VALVE WIRING!	There is a voltage on one or more valve outputs, when all outputs should be off. Check wiring to each valve coil.	3/2
135	FUNCTIONS LOCKED - ARMGUARD	During descent, the Control Module CM1 can stop movement for a configurable time (see ADJUSTMENTS/ LIFT/ ARMGUARD), to allow a safety check that no-one is close to the machine. The operator must release and then re-select DOWN to continue lowering (after the delay timeout).	2/2



**Help Messages and Fault Codes (Continued)**

Code	Message	Description	Flash Code
136	FUNCTIONS LOCKED - EXTERNAL SHUTDOWN	An external shutdown is preventing functions – check DIAGNOSTICS/SYSTEM/MODE/ INTERLOCK to see which external interlock is active.	2/2
137	FUNCTIONS LOCKED - LOW BATTERY!	Battery voltage is low. Charge batteries and check wiring.	N/A
138	FUNCTIONS LOCKED - NO VALVE SUPPLY!	Valve supply has not been supplied. Check wiring and emergency stop switches to P3-2.	N/A
139	FUNCTIONS LOCKED - NOT CALIBRATED	If platform overload functions are active (ADJUSTMENTS/OVERLOAD TRIP@, LAMP@ or ALARM@ set to a non-zero value) then both height and load must be calibrated. If overload functions are not active, but height-based decisions are active (ADJUSTMENTS/ HEIGHT values set to between 1% and 100%) then height must be calibrated. Calibration procedures are accessible from the SETUPS menu.	1/1
140	FUNCTIONS LOCKED - OVERLOADED	The platform is loaded too high to allow operation – the platform load must be reduced. If the overload features are not wanted, be sure to set ADJUSTMENTS/OVERLOAD TRIP@, LAMP@ or ALARM@ to 0%.	2/2
141	FUNCTIONS LOCKED - TEST MODE SELECTED	When the Control Module CM1 test mode has been activated (see DIAGNOSTICS/OUTPUTS), no functions are allowed. Switch power off/on to reset to normal operation.	2/2
142	FUNCTIONS LOCKED - TILTED	The machine is tilted too much to allow some functions. (see SETUPS/TILT SETUPS/TILT SHUTDOWN and ELEV.TILT SHUTDOWN).	2/2
143	FUNCTIONS LOCKED - TOO HIGH	The platform is raised too high to allow some functions. (see ADJUSTMENTS/HEIGHTS/MAX DRIVE and MAX LIFT).	2/2
144	FUNCTIONS LOCKED - TOO HOT!	Control Module CM1 heatsink temperature exceeds 75°C, preventing all functions except lowering. Check for excessive motor current draw; check for good heatsinking to machine chassis.	4/2
145	FUNCTIONS LOCKED - UNDERLOADED	Platform overload features are active, and the platform load is too low to be valid – this could be caused by erroneous calibration, a sensor fault, or a change in the machine mechanics/hydraulics. (see SETUPS/LOAD SETUPS/ FAULTY LOAD).	2/2
146	GROUND MODE ACTIVE!	The Control Module CM1 is ready to operate in Base mode when a function is selected.	N/A
147	HEIGHT NOT CALIBRATED	Height based functions are required (for example MAX DRIVE is configured), but height has not been calibrated. Calibrate height (see SETUPS/HEIGHT SETUPS) (see CALIBRATE HEIGHT procedure).	1/1
148	HELP:PRESS ENTER		N/A
149	IDLE TIMEOUT	Control Module CM1 is in standby mode after no functions have been requested in some time.	N/A
150	LIFT LOCKED - OVERRISE	KC Only - check anti-overrise limit switches to P3-10 and P3-11.	N/A
151	LIFTING!		N/A
152	LOGGED HELP		N/A

**Help Messages and Fault Codes (Continued)**

Code	Message	Description	Flash Code
153	LOWERING!		N/A
154	NOT CALIBRATED	Height and load based functions are required (for example platform overload is configured), but height and/or load has not been calibrated.	1/1
155	OVERRIDE MODE	MEWP is in Override mode. Do not operate in this mode, for servicing only. Cycle power to reset.	N/A
156	OVERRIDE=		N/A
157	OVERRISE FAULTY	KC only - check anti-overrise limit switches to P3-10 and P3-11.	N/A
158	RELEASE GROUND SWITCHES!	Base function switches were closed at power-on (or a wiring error is causing an input to be active always).	2/2
159	RELEASE JOYSTICK SWITCHES!	Platform joystick S7 switches were closed at power-on (or a wiring error is causing an input to be active always). Platform joystick switches were closed for too long without trigger switch (see SETUPS/ INTERLOCKS/TRIGGERwait).	2/2
160	RELEASE TRIGGER!	Trigger switch S7-6 Enable was closed at power-on (or a wiring error is causing the input to be active always). Trigger switch was closed for too long with no function selected (see SETUPS/ INTERLOCKS/ TRIGGERonly).	2/2
161	RETRACTING DECK!	All the above HELP messages indicate that a function is active – the machine should be moving as requested by the operator.	N/A
162	S/N=		N/A
163	SELECT DRIVE/LIFT MODE!	There is a problem with the platform S3 Drive/Lift select switch – neither mode is selected. Check wiring from S3 Drive/Lift select switch.	2/2
164	SHUTDOWN - CHECK EMS SWITCHES!	The platform and base EMS inputs indicate the mode in which the Control Module CM1 must operate. If neither input is active, or if both are active together, the Control Module CM1 does not know how to function. Check EMS switch wiring to P3-1 and P4-1.	2/1
165	STARTUP!	The Control Module CM1 has just been powered on and is carrying out some initialization steps prior to being ready to operate. If you select a function during this time, it may be locked out until you release then re-select it.	N/A
166	STEERING!		N/A
167	VEHICLE TILTED	The machine is tilted beyond the limits set by ADJUSTMENTS/TILT/Xtrip and Ytrip; some functions may be prevented	N/A

### 5.4-4 Override Mode Procedure

The Control Module CM1 prevents machine movement if not calibrated correctly. This can make it difficult to move a machine with faulty sensors to a service location.

When you put the Control Module CM1 in an “OVERRIDE” mode, none of the usual shutdowns or interlocks will occur. You can lift, lower and drive the machine freely regardless of calibration.

1. Press and hold the ESC button for 3 to 4 seconds.
2. Type in the “ACCESS LEVEL” 2 code to go into technician level 2 (see [5.4-6 Access Levels Procedure](#)).
3. Press ← or → to get to “SYSTEM OVERRIDE.”
4. Press ENTER to place the MEWP into the “OVERRIDE” mode.

### DANGER

**Risk of death or severe injury. NEVER operate a machine for normal use that is still in “OVERRIDE” mode – all of the safety and shutdown interlocks are disabled! If the LED is flashing on/off rapidly, do not use the machine.**

After you do the repairs and services and calibrate the machine again, push the emergency stop button on the base and then pull it out to disable the “OVERRIDE” permanently. The machine can now be operated normally.

### 5.4-5 Initial Set-up and Change Defaults Procedure

The model of the MEWP and battery type used must be set in the Control Module CM1 to configure the machine size and capabilities. Perform this procedure only if the Control Module CM1 was replaced.

1. Park the MEWP on level ground.
2. Press and hold the ESC button for 3 to 4 seconds.
3. Enter the “ACCESS LEVEL” 2 code to enable calibrations.
4. Press ← or → to get to “SETUPS” and press ENTER to select.
5. The display will show “MACHINE DEFAULTS” and press ENTER to select.
6. Press ENTER to run the “MODEL” option.
7. The display will show “1=3219 NA” for example, which is the machine type in North America.
8. Press ↑ until the proper machine type is listed plus the correct geographical region. (NA, KC, CE, AS, etc.).
9. Press the ESC button to exit the “MODEL” option when the correct machine type is listed to load all the preprogrammed ADJUSTMENTS and LOAD curves for that machine type.
10. Press ← or → to get to “BATTERY” and press ENTER to select.
11. The display will show “1=LEAD CELL.” Press ↑ to cycle between the following:
  - A. “1=LEAD CELL” if standard lead cell type of batteries are installed.
  - B. “2=AGM” if AGM type of batteries are installed.
12. Press ESC button to exit the “MACHINE DEFAULTS” option.
13. Cycle power to the Control Module CM1 to finish.

### 5.4-6 Access Levels Procedure

1. "ACCESS LEVEL" 1, (CODE XXXX) - FOR INITIAL FACTORY USE ONLY.
2. "ACCESS LEVEL" 2, (CODE 1122) - To access the set-ups and adjustments.
  - A. Make sure the display reads "EVERYTHING OK."
  - B. Press and hold the ESC key for 3 to 4 seconds.
  - C. Press ◀ or ▶ to find the "ACCESS LEVEL" menu and select it by pressing ENTER.
  - D. The display shows the initial code 0000. The first 0 will start flashing.
  - E. Set the first digit of the code using (↑ and ↓).
  - F. Press ▶ to move to the next digit. The first 0 will stop flashing and the second 0 will start flashing.
  - G. Set the second digit of the code.
  - H. Repeat steps D and E to set all the code digits. Make sure that the code is entered correctly. If a digit is wrong, press ◀ and ▶ to select it again and ↑ and ↓ to select the correct digit.
  - I. Press ENTER to confirm the code. The "ACCESS LEVEL" will change if the correct code is entered.
3. "ACCESS LEVEL" 3 - For daily normal operation level defaulted after cycling power.

#### PUMPMODE

4. "PUMPMODE" (CODE 1234) - Allows all electrical function to operate with P5-1 C1 Motor Contactor output disabled for troubleshooting without the pump motor engaging.



#### NOTE

*Cycling power to the control module will restore you to "ACCESS LEVEL" 3.*

### 5.4-7 Calibrate Level Procedure

The integral tilt sensor of the Control Module CM1 must be calibrated to compensate for errors due to installation or replacement of the Control Module CM1. Perform this procedure only if necessary.

1. Make sure the MEWP is parked on level ground.
2. Enter the "ACCESS LEVEL" 2 code to enable calibrations (see [5.4-6 Access Levels Procedure](#)).
3. Press ◀ or ▶ to get to the "SETUPS" menu and press ENTER to select.
4. The display shows "MACHINE DEFAULTS".
5. Press ◀ or ▶ to get to the "TILT SETUPS" menu and press ENTER to select.
6. Press ENTER to run the "CALIBRATE LEVEL" option.
7. The display will show "YES: ENTER, NO:ESC", asking for confirmation that the machine is level.
8. Press the ENTER button to confirm YES that calibration is required.
9. The display will now show the current tilt measurements. If the leveling procedure was successful then both the "X" and "Y" tilts should be about zero.
10. Press the ESC button to exit the "CALIBRATE LEVEL" option.
11. If the tilt measurements are not zero in step 9, try the procedure again – press the ESC button then the ENTER button and repeat from step 4.
12. If the tilt measurements still cannot be zeroed, check that the machine is properly parked on level ground, and check that the Control Module CM1 is correctly and securely installed on a vertical surface of the machine base with the connectors at the bottom.
13. Cycle power to the Control Module CM1 to finish.

### 5.4-8 Calibrate Load Procedure

The Control Module CM1 needs calibration before it can calculate the platform load.

#### NOTE

*This procedure is completed during factory build of the machine and ONLY needs to be performed if the Control Module CM1 is replaced.*

#### IMPORTANT

**Any changes to the machine mechanics, hydraulics, etc. may require re-calibration!**

Calibration of the MEWP automatically stops and starts the platform at various points and records the lift cylinder pressure and scissor angles at various platform heights to enable load sense:

- A. **LOADED** calibration – fully loaded platform raised & lowered with stops to take measurements.
- B. **EMPTY** calibration – unloaded platform raised & lowered with stops to take measurements.

The following procedure must be followed COMPLETELY to calibrate the Control Module CM1; throughout the procedure various checks are made – if any problem is detected the procedure stops and displays a FLASHING failure message listed at the end of this procedure.

#### NOTE

If the calibration procedure is interrupted, completed phases need not be repeated. A “REDO” prompt will appear – answer “NO” if there is no reason to repeat the phase, or “YES” if the phase must be repeated (for example, a significant mechanical or hydraulic change has been made).

#### Calibration Load Procedure

1. Make sure the MEWP is parked on level ground and Level Calibration is performed (see [5.4-7 Calibrate Level Procedure](#)).
2. Enter the “ACCESS LEVEL” 2 code to enable adjustments and calibrations (see [5.4-6 Access Levels Procedure](#)).
3. Press **←** or **→** to get to “LOAD SETUPS” and press ENTER to select.
4. Press ENTER to run the “CALIBRATE LOAD” option.

5. Make sure the MEWP is in base mode on the S10 base key switch by holding the momentary switch to base.

#### NOTE

*Continue to hold the switch or the calibration will have to be aborted and repeated from the beginning!*

6. The display will show “PLATFORM DOWN?”, asking for confirmation that the platform is stowed all the way down.
  - A. Press the ENTER button to confirm.
7. The display will show “PLATFORM LOADED?”, asking for confirmation that the platform is loaded.
  - A. Toggle between LOADED and EMPTY with the **↑** and **↓** buttons.
  - B. If rated load is available, add the rated load on the platform then press the ENTER button to confirm that calibration is done LOADED.
  - C. If no load is on the platform, make sure the platform is empty then press the ENTER button to confirm that calibration is done EMPTY.
8. The display will show “PLEASE LIFT ...”, waiting for the UP switch to be activated to begin raising the platform.
  - A. Close the UP switch and keep it closed until the platform has reached full height.
9. When the system detects the UP switch closed, the display will show “LIFT LOADED” with the current height (from 0% to 100%).
10. After a delay, the system will automatically stop the platform lift and take height & pressure measurements; the display will show “MEASURING #xx”.
  - A. When the measurements have been taken, the platform will resume lifting.

#### NOTE

*Continue to hold the switch or the calibration will have to be aborted and repeated from the beginning!*

11. The lifting ... stopping ... measuring ... lifting process will continue automatically until the platform reaches full height.
12. When the platform reaches full height (and height 100% is displayed), release the UP switch.

13. The display shows “TOTAL DATA: xx” to indicate the number of measurements taken, then shows “PLEASE LOWER ...”
  - A. Close the DOWN switch and keep it closed until the platform is fully lowered.
14. When the system detects the DOWN switch closed, the display will show “LOWER LOADED” with the current height (from 100% to 0%).
15. Again after a delay, the system will automatically stop the platform lower and take height & pressure measurements; the display will show “MEASURING #xx.”
  - A. When the measurements have been taken, the platform will resume lowering.



### NOTE

*Continue to hold the switch or the calibration will have to be aborted and repeated from the beginning!*

16. The lowering ... stopping ... measuring ... lowering process will continue automatically until the platform is fully lowered.
17. When the platform is fully lowered (and height 0% is displayed), release the DOWN switch; the display shows “TOTAL DATA: xx” to indicate the number of measurements taken.
18. The load calibration “LOADED” phase is complete.

### Calibration Date

19. The display will show “CALDATE: mm/dd/yy” with the “mm” value flashing.
  - A. It is recommended that the current date be entered here to provide easy tracking of the date of last calibration (the date can be seen in the “LOG” menu available in the “DIAGNOSTICS” menu).
  - B. Use ↑ and ↓ to set the month, then press → to move to the date; set the date and then the year in the same way.
  - C. Press ENTER to complete date entry (the system will store it).
20. The display will show “FINISHED!”

### IMPORTANT

**Press the ESC button a few times to exit the “CALIBRATE LOAD” option and return to the home screen (it’s not possible to use the machine if you don’t do this).**

21. The Control Module CM1 is now fully calibrated.

### 5.4-9 Language Setting Procedure

The Skycoded display panel shows the operator the status of the machine in real time. If the operator raises the platform, the Skycoded display will show “151:LIFTING!” These messages and associated codes can be found in the [Help Messages and Fault Codes](#) table. These messages can be shown in different languages according to the user preference.

#### Change the language setting

1. Make sure the display is on the home page. If not, push and pull the emergency stop button on the base to cycle the power on your machine.
2. Press and hold the **↑** button for 3 to 4 seconds.
3. The display will show the language selection.
4. Press **↑** or **↓** to change the language.
5. Wait 3 to 4 seconds. The display will automatically go back to the home page with the new language.



### 5.4-10 Calibration Fault Codes

During calibration, the Control Module CM1 repeatedly checks for possible problems, which might prevent successful calibration, or subsequently give inaccurate platform load estimates.

If any problems are detected, a flashing error message is immediately displayed and calibration is terminated – the problem must be resolved, and then calibration must be restarted.

#### Fault Code List

Most calibration error messages have an “Fxx” number as well as a description, to aid in trouble-shooting.

Fault Code	Description
F01:CANNOT RUN	Something is wrong, preventing the Control Module CM1 from running – check the HELP message (causes include line contactor, valve, or motor wiring errors).
F02:NOT GROUND MODE	Calibration can only be carried out from base control!
F03:NOT STOPPED	The machine must not already be moving when calibration started.
F04:TILTED	The machine must be on level ground when calibration started.
F05:BAD HEIGHT1	At the start of calibration, the Angle Transducers are out of range (output must be between 0.9V and 4.1V with Platform fully lowered).
F05:BAD HEIGHT2	
F06:CHECK ELEV	At the start of calibration, the Angle Transducers require calibration with Platform fully lowered.
F07:BAD HEIGHTS	During calibration, the two Angle Transducers disagreed too much.
F08:CHECK ELEV	The Angle Transducers require calibration with the platform fully raised.
F09:BAD HEIGHT1	The Angle Transducers are out of range when fully lowered (0%) calibration is recorded (output must be between 0.9V and 4.1V with platform fully lowered).
F09:BAD HEIGHT2	
F10:BAD HEIGHT1	The Angle Transducers are out of range when fully raised (100%) calibration is recorded (output must be between 0.6V and 4.4V with platform fully raised).
F10:BAD HEIGHT2	
F11:NOT UP	When instructed to go up (raise the Platform) the DOWN switch was activated.
F11:NOT DOWN	
F13:LOW HEIGHT RANGE	There is not enough difference between the Angle Transducers output when fully lowered, and fully raised (minimum allowed difference is 1V). Make sure the UP switch is not released before the platform is fully raised.
F20:HEIGHT1 <> 0%	After fully raising and fully lowering the Platform, during dynamic or static calibration, we should always be back at 0% height!
F20:HEIGHT2 <> 0%	
F22:HEIGHT1 <> 100%	After fully raising the Platform, during static calibration, we should always lift to 100% height!
F22:HEIGHT2 <> 100%	
F27:BAD HEIGHT	During static (loaded or empty) calibration, the platform height is out of range (below 0% or above 100%, or below 0.4V or above 4.6V).



**Fault Code List (Continued)**

Fault Code	Description
F44:LOW PRESSURE	During static (loaded or empty) calibration, the lift cylinder pressure is out of range (below 0.4V or above 4.6V).
F48:BAD PRESSURE	At the start of calibration, the pressure sensor is out of range (output must be between 0.3V and 4.8V at all times)
F52:NOT CALIBRATED!	Something happened to cause calibration to fail – it is recommended to check all sensor wiring for loose connections, then repeat calibration.
FINISHED!	This display occurs when all calibrations (dynamic, loaded up, loaded down, empty up, empty down) have been completed, and the CALDATE has been entered.  Be sure to press <ESC> on the display module to exit calibration, before attempting to use the machine.
GO UP MORE!	During calibration, the operator needs to close the UP or DOWN switch as required to lift or lower the platform – if the switch is closed in the wrong direction, no fault occurs but the machine does not move! This display clarifies the error.
GO DOWN MORE!	
PLEASE WAIT	During calibration, the Control Module CM1 sometimes delays while waiting for sensor values to stabilize – this display indicates why nothing appears to be happening.

**Non-applicable fault codes**

There are additional fault codes that may show up on the Skycoded display panel that does not affect your machine. If you see the following fault codes, calibrate the load [5.4-8 Calibrate Load Procedure](#) and level [5.4-7 Calibrate Level Procedure](#) of your machine again. If the fault codes continue, contact the Skyjack service department.

Non-applicable Fault Codes			
F12:TOO MANY	F19:HIGH ELEV.CLOSE	F42:LOW PRESSURE	IGNORING
F14:BAD HEIGHT1	F24:TOO MANY	F43:HIGH PRESSURE	
F15:CHECK ELEV	F30:BAD HEIGHTS	F45:HIGH PRESSURE	
F16:LOW ELEV.OPEN	F34:REJECT CURVE	F46:CHECK ELEV	
F17:HIGH ELEV.OPEN	F40:REJECT DELTA DOWN @	F47:CHECK ELEV	
F18:LOW ELEV.CLOSE	F40:REJECT DELTA UP @	F49:TOO FEW	



**SKYJACK**<sup>™</sup>

[www.skyjack.com](http://www.skyjack.com)